

Nano Coax Connectors – Standalone Cable Mate – RF Characterization

T160110 Rev3 – July 11, 2018

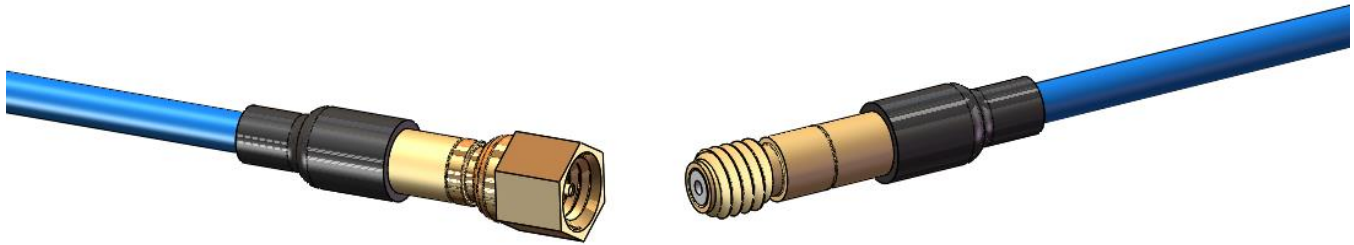

1. Product Description

- 1.1. Assembly P/N:A75588-001 mated to A75589-001 & A75591-001 mated to A75593-001
- 1.2. Connector Description: Nano Coax Cable Mated connectors
- 1.3. Cable: Temp-Flex 047SC-2901

2. Test Summary

- 2.1. VSWR: 1.25:1 to 20 GHz
- 2.2. Return Loss: -25 dB to 20 GHz
- 2.3. Insertion Loss: -1.0 dB to 20 GHz
- 2.4. Impedance: $50\Omega \pm 2.5\Omega$
- 2.5. Crosstalk: < -70dB to 20 GHz (FEXT); < -70 dB to 20 GHz (NEXT)

Frequency Range	DC to 20 GHz		
	Freq Range	Gated ¹	Non-Gated
VSWR	DC - 10 GHz	1.2:1	1.3:1
	10 GHz - 20 GHz	1.25:1	1.4:1
Return Loss	DC - 10 GHz	-27 dB	-16 dB
	10 GHz - 20 GHz	-25 dB	-15 dB
Insertion Loss	DC - 10 GHz	-0.7 dB	-1.7 dB
	10 GHz - 20 GHz	-1.0 dB	-2.3 dB
Impedance	$50\Omega \pm 2.5\Omega$		
Crosstalk (FEXT)	DC - 20 GHz	< -70 dB	N/A
Crosstalk (NEXT)	DC - 20 GHz	< -70 dB	N/A

¹ See Appendix 3 for explanation of gating.

2.1 Voltage Standing Wave Ratio (VSWR)

Voltage Standing Wave Ratio (VSWR) measures the amount of signal that is reflected back to the source.

VSWR	Freq Range	Gated	Non-Gated
	DC - 10 GHz	1.2:1	1.3:1
	10 GHz - 20 GHz	1.25:1	1.4:1

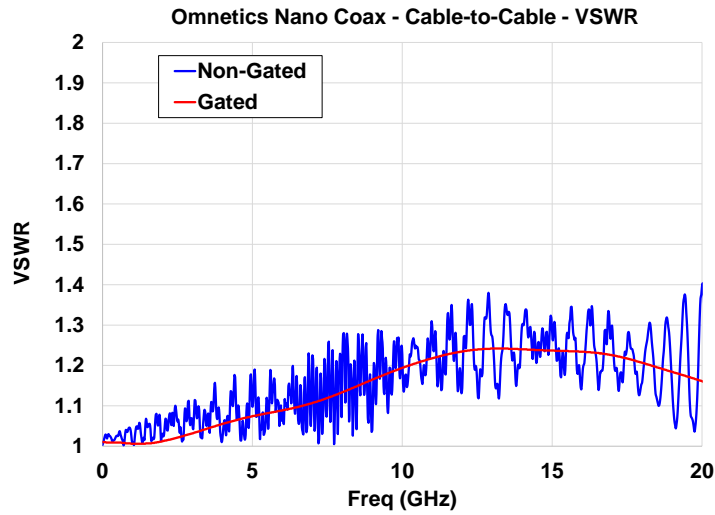

2.2 Return Loss

Return loss is the ratio of the reflected signal to the incident signal.

Return Loss	Freq Range	Gated	Non-Gated
	DC - 10 GHz	-27 dB	-16 dB
	10 GHz - 20 GHz	-25 dB	-15 dB

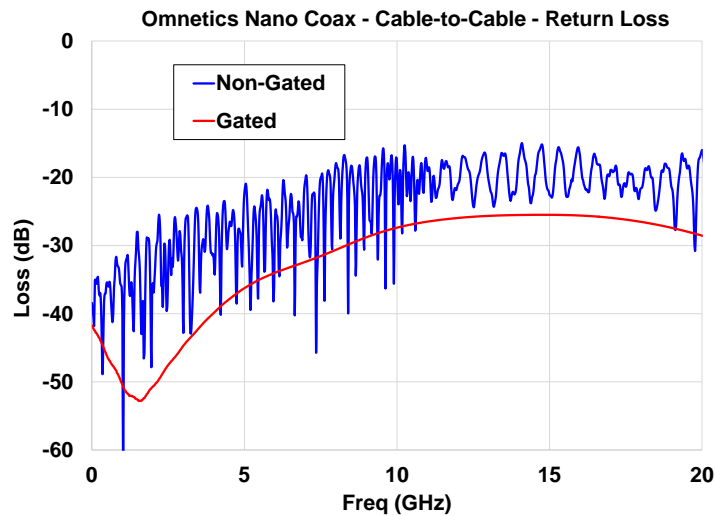

2.3 Insertion Loss

Insertion loss is the ratio of the transmitted signal to the incident signal.

Insertion Loss	Freq Range	Gated	Non-Gated
	DC - 10 GHz	-0.7 dB	-1.7 dB
	10 GHz - 20 GHz	-1.0 dB	-2.3 dB

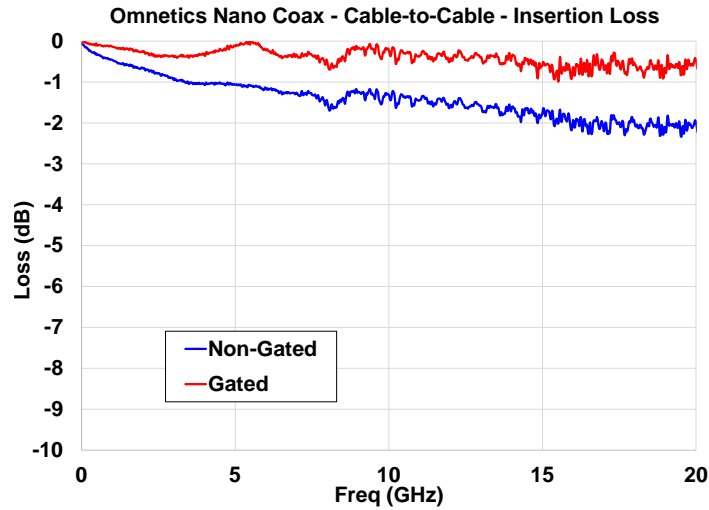

2.4 TDR (Impedance)

TDR (Time Domain Reflectometer) is a measure of the impedance through the cable/coax assembly. TDR results are provided below based on a 100ps rise time (0%-100%).

Impedance	$50\Omega \pm 2.5\Omega$
-----------	--------------------------

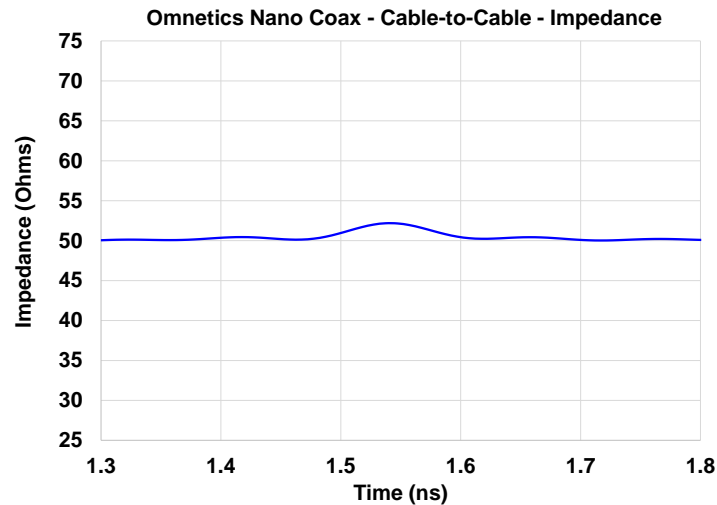

2.5 Crosstalk

Crosstalk is measured by using adjacent contacts in a Micro Circular connector. The contact spacing is 125mil. The image on the left is the measured connector. The connector on the right is to show the internal design of the connector – it is not measured in this configuration and is for demonstration purposes only.



Crosstalk is the ratio of the transmitted signal to the coupled signal on the adjacent path. FEXT (Far-End Crosstalk) is measured on the far side of the adjacent path. NEXT (Near-End Crosstalk) is measured on the near side of the adjacent path.

	Freq Range	FEXT	NEXT
Crosstalk	DC - 20 GHz	< -70 dB	< -70 dB

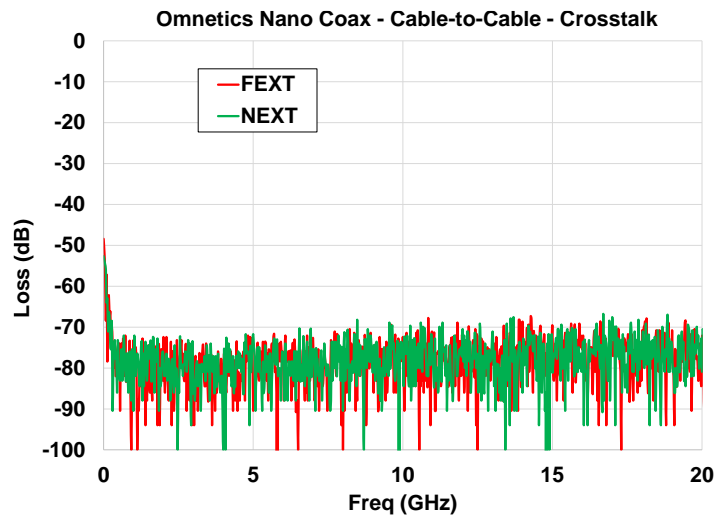

Appendix 1 – Nano Coax Model

Below is a 2D-view of the mated Nano Coax contact. Since the internal geometries are identical for both the push-on version (A75588-001 & A75589-001) and the threaded version (A75591-001 & A75593-001), the results in this report apply to both.

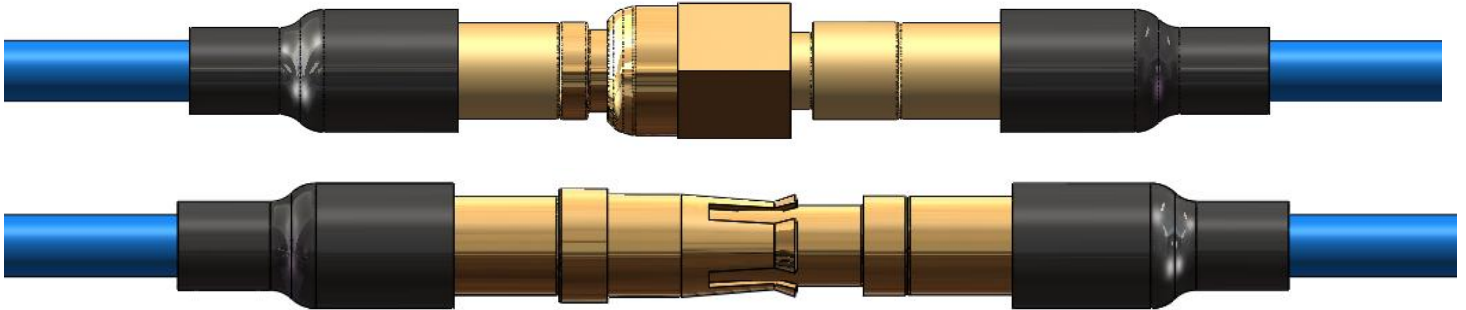

Appendix 2 – Measured Path

A basic diagram for the measured path is shown below. The assembly uses a Molex 73252-0130 2.92mm connector and a Temp-Flex 047SC-2901 50Ω cable.



Appendix 3 – What is Gating?

Gating is a mathematical function that removes undesired responses from portions of the measured path. In the case of this report, the focus was the mated Nano Coax. In order to achieve the performance of this specific portion of the path, the remaining portion was gated out.

The initial measurement was for the entire path shown in **Figure A 1**:



Figure A 1. Full measured assembly.

The gate function removed the impact from the portions shown in **Figure A 2**:

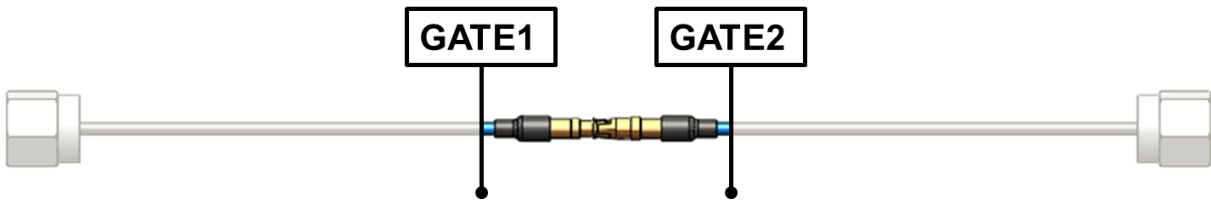

Figure A 2. Measured assembly with gating enabled.

The results is the performance of the path shown in **Figure A 3**:



Figure A 3. The path of the measured gated results.

Appendix 4 - Equipment List:

VNA	Agilent 8722ES
Test Fixtures	Omnetics Custom

Revision Control:

Rev1	7/13/2016 – Initial Revision
Rev2	7/18/2016 – Added cable and connector description, page 1; added crosstalk measurement
Rev3	7/11/2018 – Modified format to standardize for all high-speed reports