

METAL MICRO-D BOARD MOUNT LAYOUT

METAL MICRO-D HORIZONTAL SURFACE MOUNT (HO)

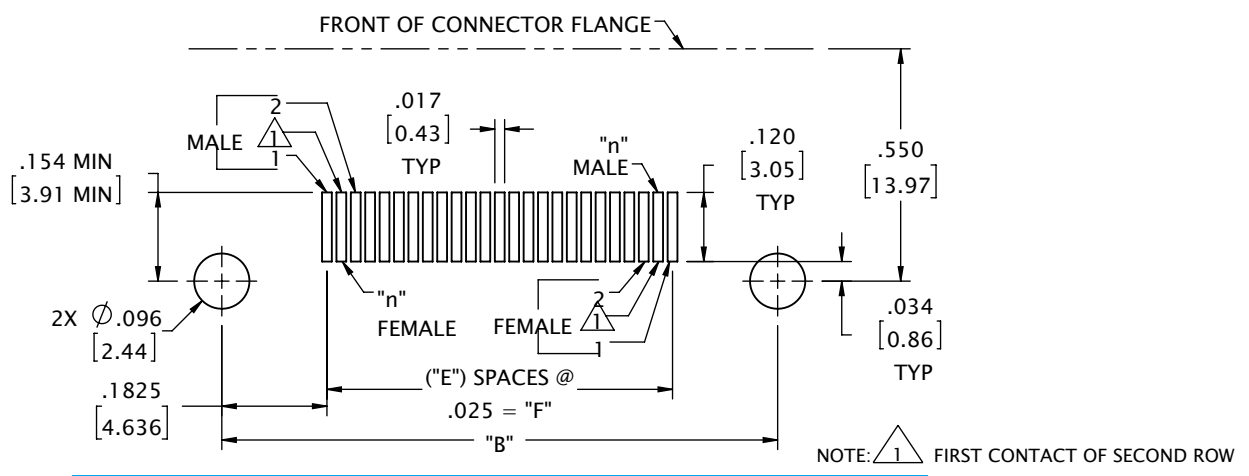

CONTACTS	ROWS	"B"	"E"	"F"
9	2	.565 [14.35]	8	.200 [5.08]
15	2	.715 [18.16]	14	.350 [8.89]
21	2	.865 [21.97]	20	.500 [12.70]
25	2	.965 [24.51]	24	.600 [15.24]
31	2	1.115 [28.32]	30	.750 [19.05]
37	2	1.265 [32.13]	36	.900 [22.86]
51	2	1.615 [41.02]	50	1.250 [31.75]

DIMENSIONS IN [] ARE IN MILLIMETERS AND ARE FOR REFERENCE ONLY

METAL MICRO-D VERTICAL SURFACE MOUNT (VV)

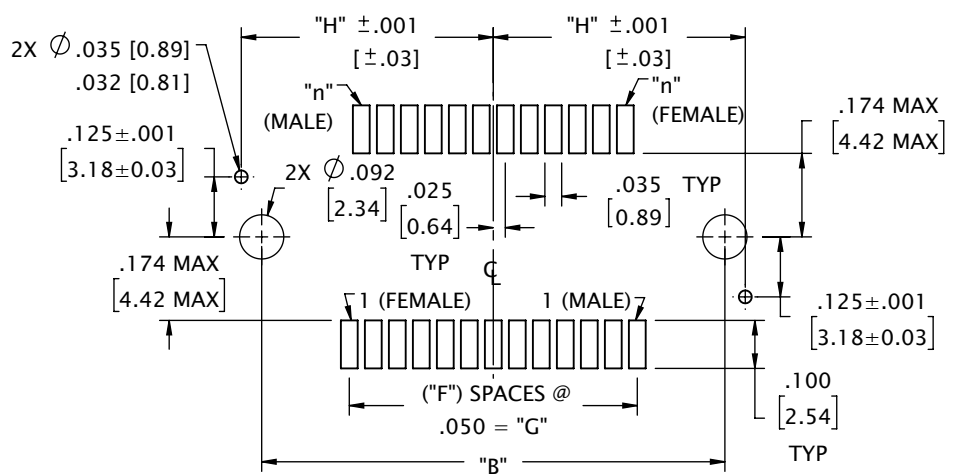

CONTACTS	ROWS	"B"	"F"	"G"	"H"
9	2	.565 [14.35]	4	.200 [5.08]	.325 [8.26]
15	2	.715 [18.16]	7	.350 [8.89]	.400 [10.16]
21	2	.865 [21.97]	10	.500 [12.70]	.475 [12.07]
25	2	.965 [24.51]	12	.600 [15.24]	.525 [13.34]
31	2	1.115 [28.32]	15	.750 [19.05]	.600 [15.24]
37	2	1.265 [32.13]	18	.900 [22.86]	.675 [17.15]
51	2	1.615 [41.02]	25	1.250 [31.75]	.850 [21.59]

DIMENSIONS IN [] ARE IN MILLIMETERS AND ARE FOR REFERENCE ONLY

METAL MICRO-D CARD EDGE SURFACE MOUNT (CO)

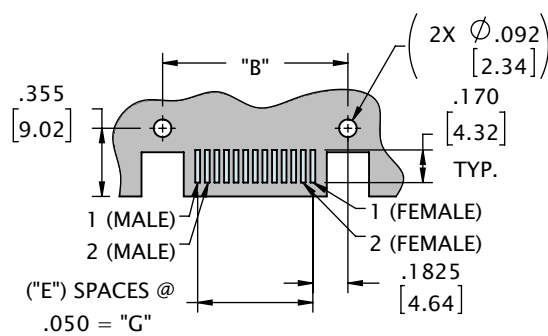

BOTTOM OF BOARD

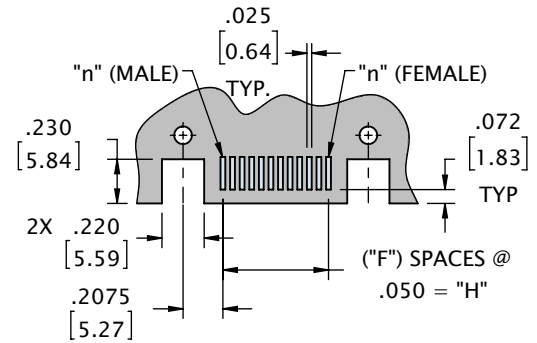

TOP OF BOARD

CONTACTS	ROWS	"E"	"F"	"B"	"G"	"H"
9	2	4	3	.565 [14.35]	.200 [5.08]	.150 [3.81]
15	2	7	6	.715 [18.16]	.350 [8.89]	.300 [7.62]
21	2	10	9	.865 [21.97]	.500 [12.70]	.450 [11.43]
25	2	12	11	.965 [24.51]	.600 [15.24]	.550 [13.97]
31	2	15	14	1.115 [28.32]	.750 [19.05]	.700 [17.78]
37	2	18	17	1.265 [32.13]	.900 [22.86]	.850 [21.59]
51	2	25	24	1.615 [41.02]	1.250 [31.75]	1.200 [30.48]

DIMENSIONS IN [] ARE IN MILLIMETERS AND ARE FOR REFERENCE ONLY

METAL MICRO-D FLEX TAIL (FF)

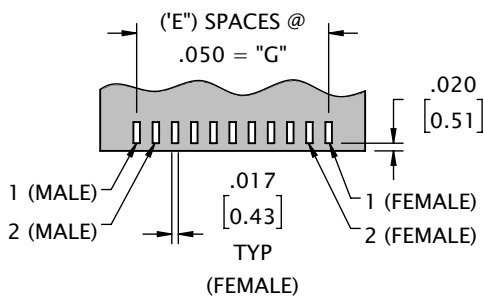

BOTTOM OF BOARD

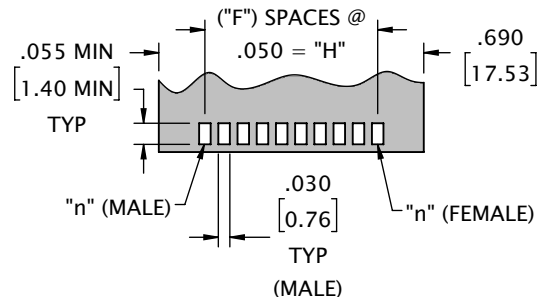
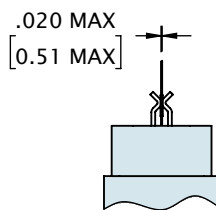

TOP OF BOARD

CONTACTS	ROWS	"E"	"F"	"G"	"H"
9	2	4	3	.200 [5.08]	.150 [3.81]
15	2	7	6	.350 [8.89]	.300 [7.62]
21	2	10	9	.500 [12.70]	.450 [11.43]
25	2	12	11	.600 [15.24]	.550 [13.97]
31	2	15	14	.750 [19.05]	.700 [17.78]
37	2	18	17	.900 [22.86]	.850 [21.59]
51	2	25	24	1.250 [31.75]	1.200 [30.48]

DIMENSIONS IN [] ARE IN MILLIMETERS AND ARE FOR REFERENCE ONLY

METAL MICRO-D BOARD MOUNT LAYOUT

METAL MICRO-D STRAIGHT THRU-HOLE (DD)

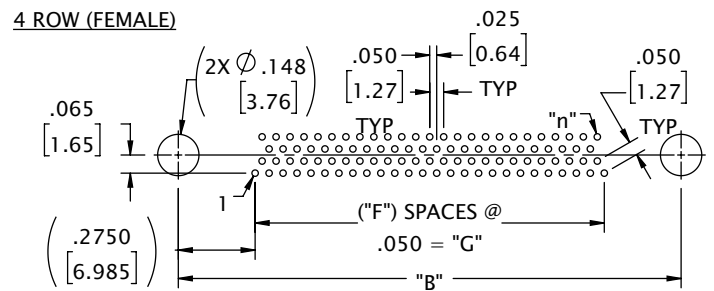
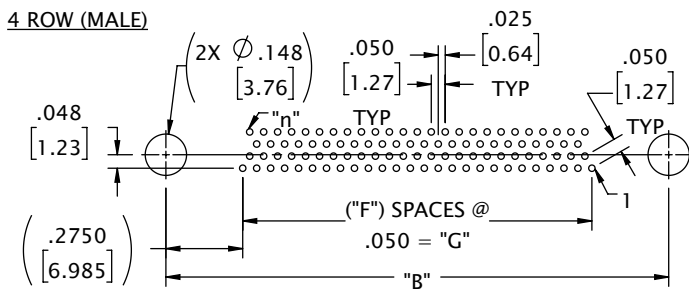
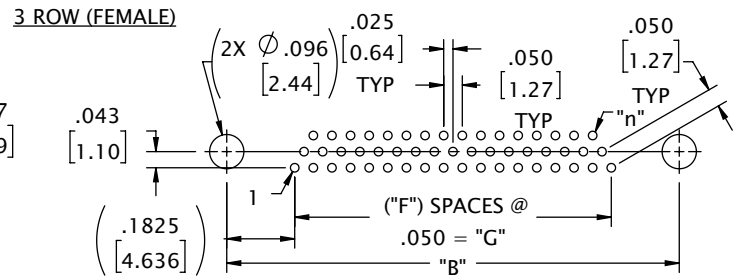
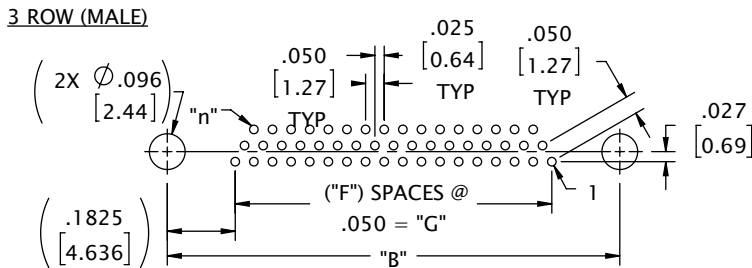
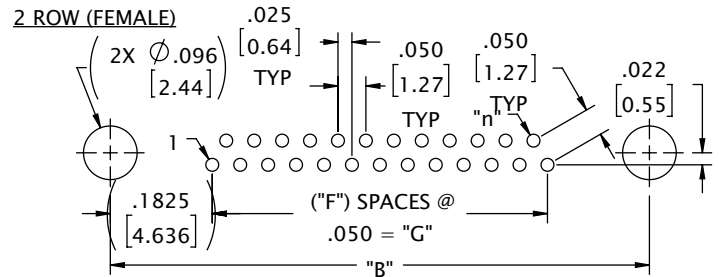
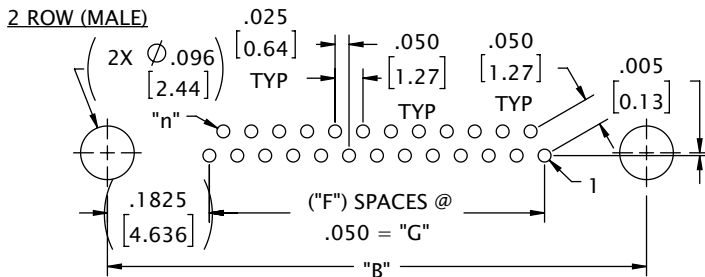

CONTACTS	ROWS	"B"	"F"	"G"
9	2	.565 [14.35]	4	.200 [5.08]
15	2	.715 [18.16]	7	.350 [8.89]
21	2	.865 [21.97]	10	.500 [12.70]
25	2	.965 [24.51]	12	.600 [15.24]
31	2	1.115 [28.32]	15	.750 [19.05]
37	2	1.265 [32.13]	18	.900 [22.86]
51	2	1.615 [41.02]	25	1.250 [31.75]
51	3	1.215 [30.86]	17	.850 [21.59]
69	3	1.515 [38.48]	23	1.150 [29.21]
100	4	1.800 [45.72]	25	1.250 [31.75]

DIMENSIONS IN [] ARE IN MILLIMETERS AND ARE FOR REFERENCE ONLY

METAL MICRO-D RIGHT ANGLE THRU-HOLE (H2)

2 ROW

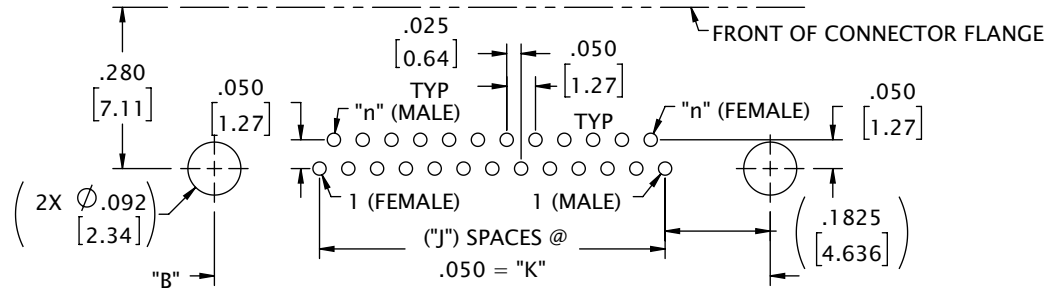

3 ROW

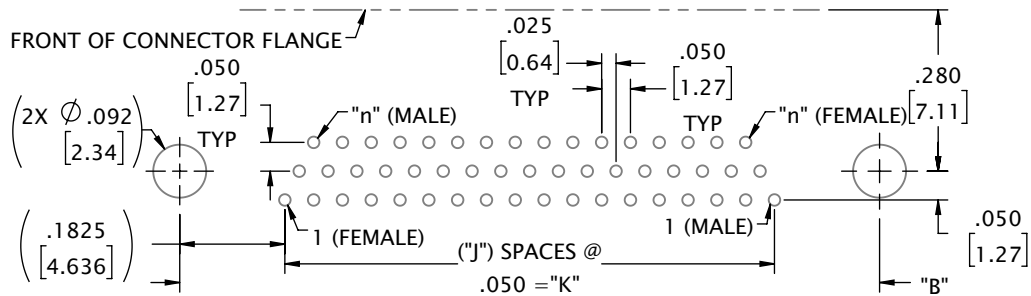

4 ROW

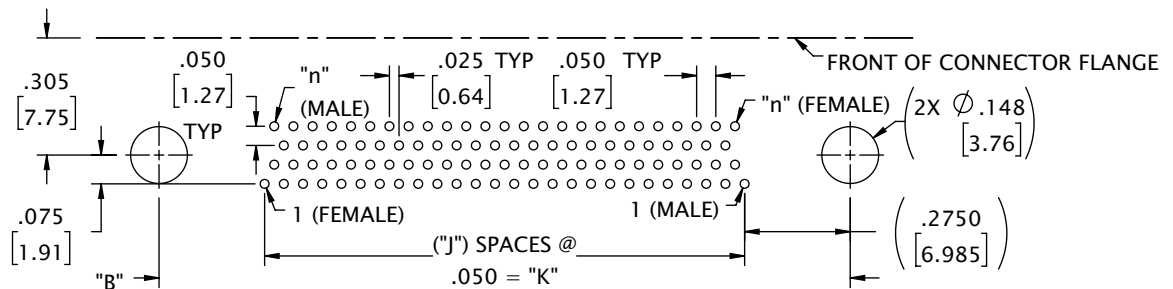

CONTACTS	ROWS	"B"	"F"	"G"
9	2	.565 [14.35]	4	.200 [5.08]
15	2	.715 [18.16]	7	.350 [8.89]
21	2	.865 [21.97]	10	.500 [12.70]
25	2	.965 [24.51]	12	.600 [15.24]
31	2	1.115 [28.32]	15	.750 [19.05]
37	2	1.265 [32.13]	18	.900 [22.86]
51	2	1.615 [41.02]	25	1.250 [31.75]
51	3	1.215 [30.86]	17	.850 [21.59]
69	3	1.515 [38.48]	23	1.150 [29.21]
100	4	1.800 [45.72]	25	1.250 [31.75]

DIMENSIONS IN [] ARE IN MILLIMETERS AND ARE FOR REFERENCE ONLY

METAL MICRO-D BOARD MOUNT LAYOUT

METAL MICRO-D NARROW RIGHT ANGLE .100 (SR1)

9 CONTACT
PLUG

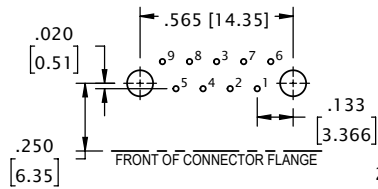

9 CONTACT
RECEPTACLE

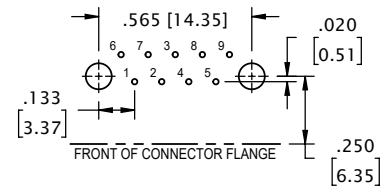

15 CONTACT
PLUG

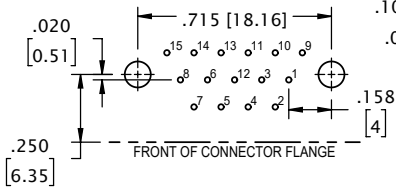

15 CONTACT
RECEPTACLE

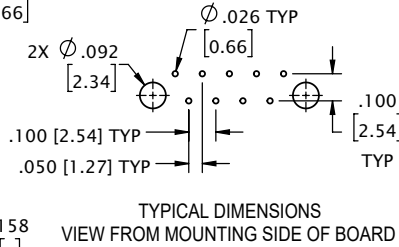
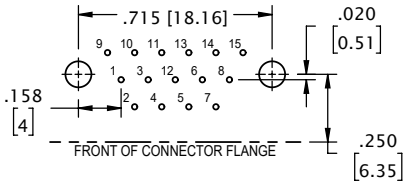

21 CONTACT
PLUG

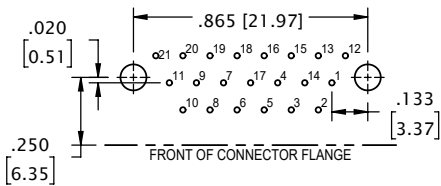

21 CONTACT
RECEPTACLE

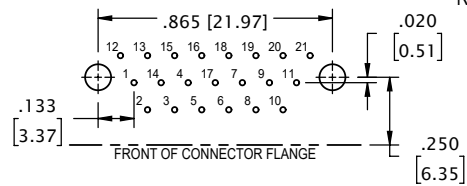

25 CONTACT
PLUG

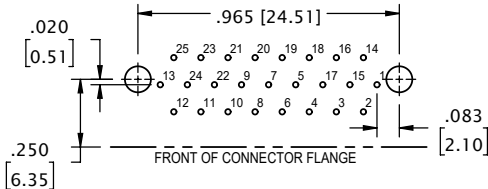

25 CONTACT
RECEPTACLE

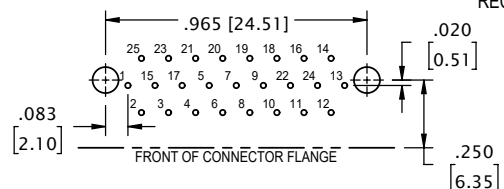

31 CONTACT
PLUG

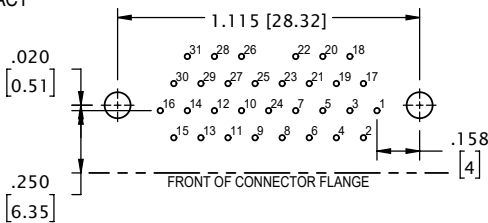

31 CONTACT
RECEPTACLE

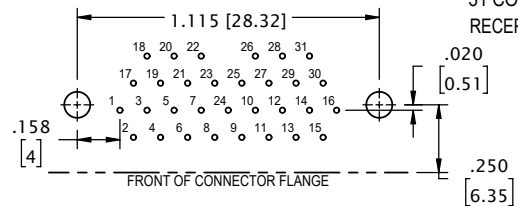

37 CONTACT
PLUG

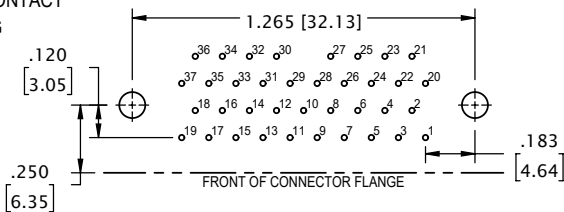

37 CONTACT
RECEPTACLE

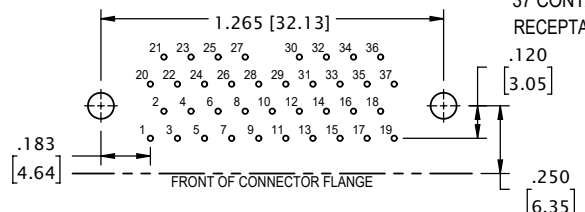

51 CONTACT
PLUG

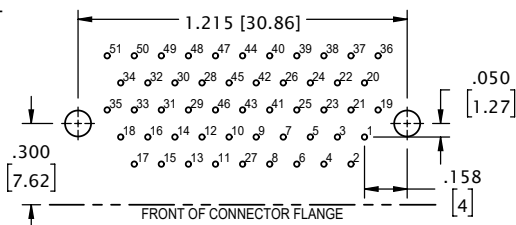

51 CONTACT
RECEPTACLE

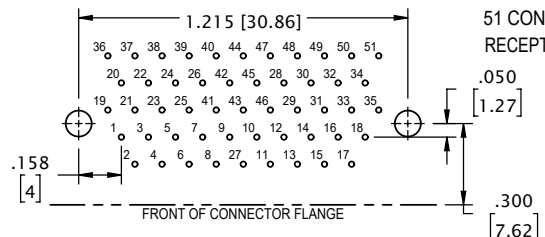

METAL MICRO-D BOARD MOUNT LAYOUT

METAL SHELL MICRO-D STANDARD VERTICAL BOARD MOUNT .075 (TYPE SV7)

9 CONTACT
PLUG

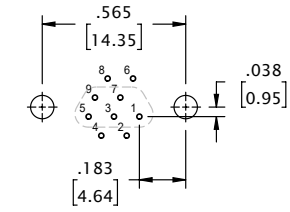

9 CONTACT
RECEPTACLE

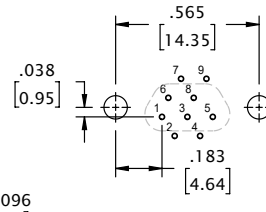

TYPICAL DIMENSIONS

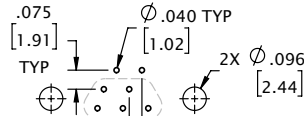

15 CONTACT
PLUG

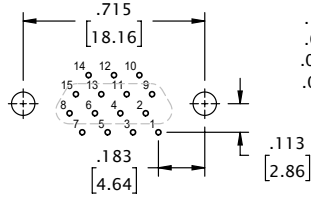

15 CONTACT
RECEPTACLE

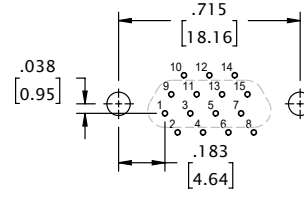

.100 [2.54] TYP
.075 [1.91] TYP
.050 [1.27] TYP
.025 [0.64] TYP
VIEW FROM MOUNTING
SIDE OF BOARD
NOTE MATE ORIENTATION

21 CONTACT
PLUG

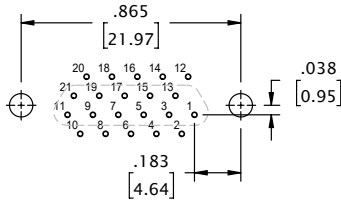

21 CONTACT
RECEPTACLE

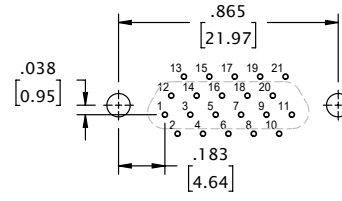

25 CONTACT
PLUG

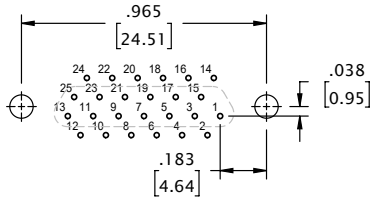

25 CONTACT
RECEPTACLE

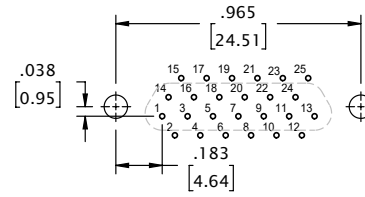

31 CONTACT
PLUG

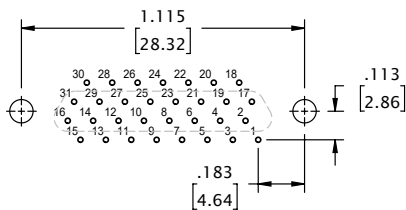

31 CONTACT
RECEPTACLE

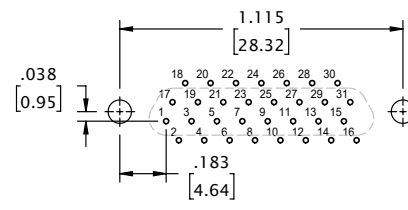

37 CONTACT
PLUG

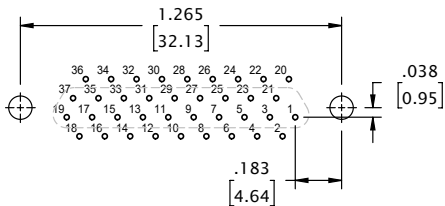

37 CONTACT
RECEPTACLE

