

A PERFECT ALLIANCE.

ODU THREADED CONNECTOR TECHNOLOGY

Advanced Connectors For Harsh Environments

HIGH RELIABILITY



A PERFECT ALLIANCE.



A PERFECT ALLIANCE.

ODU GROUP OVERVIEW

- More than 75 years of experience in connector technology
- A turnover of 170 million Euro
- Over 1,900 employees worldwide
- 9 sales subsidiaries in China, Denmark, France, Germany, Italy, Japan, Sweden, the UK and the US as well as 5 production and logistics sites
- All technologies under one roof: Design and development, machine tool and special machine construction, injection, stamping, turning, surface technology, assembly and cable assembly

As of February 2018

CERTIFIED QUALITY

- DIN EN ISO 9001
- IATF 16949
- DIN EN ISO 14001
- ISO 13485
- Wide range of UL, CSA, VG and DVA licenses
- UL certified cable assembly

CUSTOMER-SPECIFIC SOLUTIONS

Contacts, connectors and integrated cable assembly solutions meeting the most demanding technical market requirements – ODU's connector solutions and value-added services are characterized by their exclusive focus on meeting the customer's needs.

- Precise implementation of application-specific requirements regarding design, functionality, cost and exclusivity
- Custom connector solutions derived from standard products
- One-to-one local expertise and fair, friendly consulting
- Quick prototyping and production turnaround



For a complete list of our certifications, please visit our website.

www.odu-connectors.com

CREATING CONNECTIONS, BUILDING ALLIANCES, COLLABORATING INTO THE FUTURE



Dr.-Ing. Kurt Woelfl

Managing Director

Corporate Development, Engineering, Finance/Controlling, Human Resources, IT & Business Processes, Production, Quality Management, Research & Development, Supply Chain Management

Denis Giba

Managing Director

Corporate Communications/Marketing, Corporate Development, Portfolio Management, Sales

TECHNOLOGY THAT UNITES – CONNECTIONS THAT INSPIRE

For over 75 years, this commitment has enabled us to innovate and provide solutions that respond to continuously changing market needs. We provide high-quality electrical connectors that create added value for our customers and any market player seeking a reliable connector solution to enable the transmission of power, signals, media and data transmission.

A PERFECT ALLIANCE is our guiding principle. It represents the synergy between our high-quality connector solutions and the strong partnerships we build with our staff and business partners across the globe – partnerships based on trust, reliability and mutual respect.

ODU is one of the world's leading suppliers of connector systems today, employing over 1,900 people worldwide and generating approximately €170 million in sales. To ensure the very highest quality standards in our cutting-edge products, we continuously invest in their development and production – and ultimately, in our very unique expertise. Over the past few years, our development of customer- and application-specific connectors has led to the sustained growth of our standard product range so that today, we cover a broad range of application areas. A balance between project-specific business, including customized developments, and standard connector design will continue to shape our business into the future. This holds true

for emerging and future markets, such as medical, military and security, and energy, as well as for the special requirements of measurement and testing, eMobility and industrial electronics.

A PERFECT ALLIANCE – The future of ODU will continue to find solid ground for growth: in our focus on providing reliable connector solutions for a variety of challenging applications and in our commitment to continuously expanding our technology portfolio. It's what we do and who we are – around the globe. This brochure is an invitation for you to become even better acquainted with ODU, an internationally active technology company devoted to creating high-quality customized connector solutions.

We are actively shaping the future of our company with creativity, imagination and innovation in order to serve our valued customers around the world.

ODU – A PERFECT ALLIANCE.

The Managing Directors:

Dr.-Ing. Kurt Woelfl and Denis Giba

ADVANCED CONNECTOR SOLUTIONS

ODU THREADED CONNECTOR TECHNOLOGY



THREADED CONNECTORS

ODU offers a wide variety of robust technologies for applications in harsh environments. ODU's Threaded Connector technologies are especially favored for applications requiring an additional degree of security, or where environmental conditions including temperature, pressure or vibration would be problematic for other interconnect products.

KEY FEATURES AND CUSTOMER BENEFITS

- Lightweight, small and easy handling
- Wide temperature range
- Various standard inserts available
- Individual contact configuration available on request
- Reliable data transmission and excellent shielding performance
- System solution – cable assembly and overmolding

A LEGACY OF EXCELLENCE...



- ⊕ Leakage rate: 1×10^{-8} mbar \times l / s (Helium)
- ⊕ Stainless steel

- ⊕ Hydrostatic pressure: up to 500 bar
- ⊕ High corrosion resistant

- ⊕ IP 68 mated
- ⊕ > 1000 mating cycles

TECHNOLOGY AT A GLANCE

ODU THREADED CONNECTOR



EMI SHIELDED

Tested according MIL STANDARDS

HIGH VIBRATION Resistant

RACHET MECHANISM half turn locking

WATERTIGHT

Triple start THREADED

More MATE CYLES than MIL spec. connectors

RUGGED solid construction

FULL MATE indicator

MECHANICAL KEYING with matched color code

COMPACT design

2 SHELL SIZES

SIZE 1.5

- From 8–19 contacts
- Small size
- Ethernet¹ ready



SIZE 3

- From 4–26 contacts
- High power
- Combo inserts available



2 MECHANICAL (COLOR) CODINGS



¹These ODU specific connectors can transmit common data transmission protocols such as Ethernet, but they are not Ethernet-standard connectors.

PLUG – SOLDER CUP

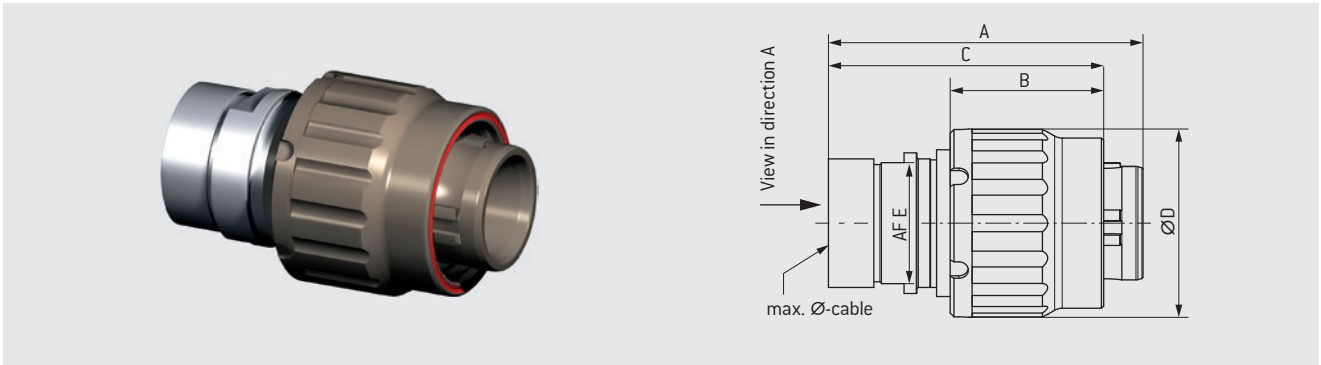

Size	A	B	C	ØD	AFE	Max. Ø-cable
1.5	34.1	15.7	31.1	17.5	11	8.5
3	41.6	20.3	36.4	24.9	16	12.8

Available codings: brown and red

CONTACT CONFIGURATIONS

Size	Layout viewed from direction A	Number of solder contacts	Max. current [A] single contact load	DWV voltage ¹ [VAC]	Max. wire size solder cup	Suitable for
1.5		10 × pin	5	1200	10 × AWG 22	Signal
		19 × pin	2	1000	19 × AWG 26	Signal
		8 × pin	5	1200	8 × AWG 22	CAT 5 ² Gigabit Ethernet ²
3		4 × socket	20	1650	4 × AWG 14	Power
		2 × socket	30	1350	2 × AWG 12	Power
		3 × pin	5	1350	3 × AWG 22	Signal
		18 × pin	7	1200	18 × AWG 20	Signal
	26 × pin	5	1000	26 × AWG 22	Signal	

Notes: Consult factory for availability. For various applications, the safety requirement regarding the operating voltage is even more severe. This must be evaluated during the time of equipment engineering.

¹ Consult factory for additional information and options.

² These ODU specific connectors can transmit common data transmission protocols such as Ethernet and CAT 5, but they are not Ethernet- or CAT-standard connectors.

RECEPTACLE STYLE 8 – SOLDER CUP

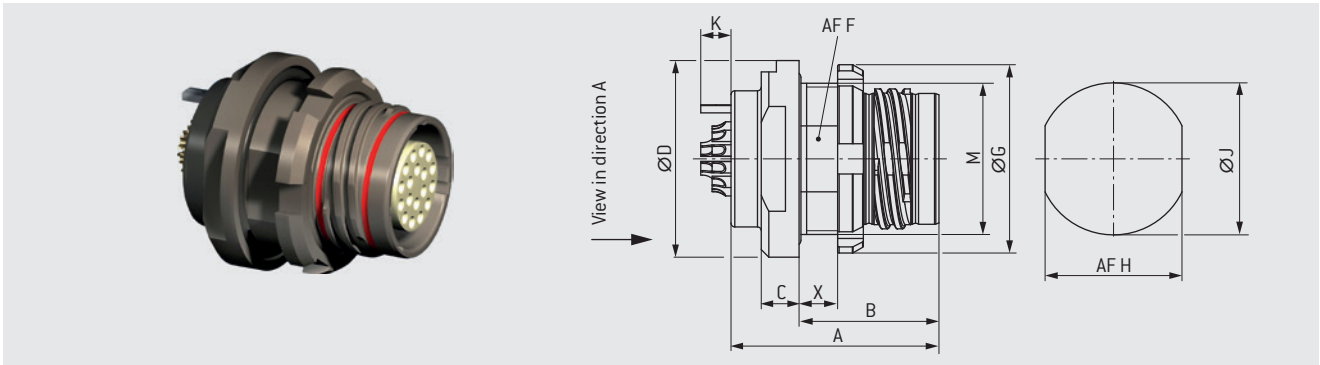

Size	A	B	C	ØD	AF F	ØG	AF H	ØJ	K	M	X max.
1.5	20.5	14	4	18.9	13	17.9	13.1	14.1	3.5	M14 × 0.75	4
3	27.5	18.5	5	26	18	24.9	18.1	20.1	4	M20 × 1.00	5.1

Available codings: brown and red

CONTACT CONFIGURATIONS

Size	Layout viewed from direction A	Number of solder contacts	Max. current [A] single contact load	DWV voltage ¹ [VAC]	Max. wire size solder cup	Suitable for
1.5		10 × socket	5	1200	10 × AWG 22	Signal
		19 × socket	2	1000	19 × AWG 26	Signal
		8 × socket	5	1200	8 × AWG 22	CAT 5 ² Gigabit Ethernet ²
3		4 × pin	20	1650	4 × AWG 14	Power
		2 × pin	30	1350	2 × AWG 12	Power
		3 × socket	5	1350	3 × AWG 22	Signal
		18 × socket	7	1200	18 × AWG 20	Signal
	26 × socket	5	1000	26 × AWG 22	Signal	

Notes: Consult factory for availability. For various applications, the safety requirement regarding the operating voltage is even more severe. This must be evaluated during the time of equipment engineering.

¹ Consult factory for additional information and options.

² These ODU specific connectors can transmit common data transmission protocols such as Ethernet and CAT 5, but they are not Ethernet- or CAT-standard connectors.

RECEPTACLE STYLE 8 – PCB

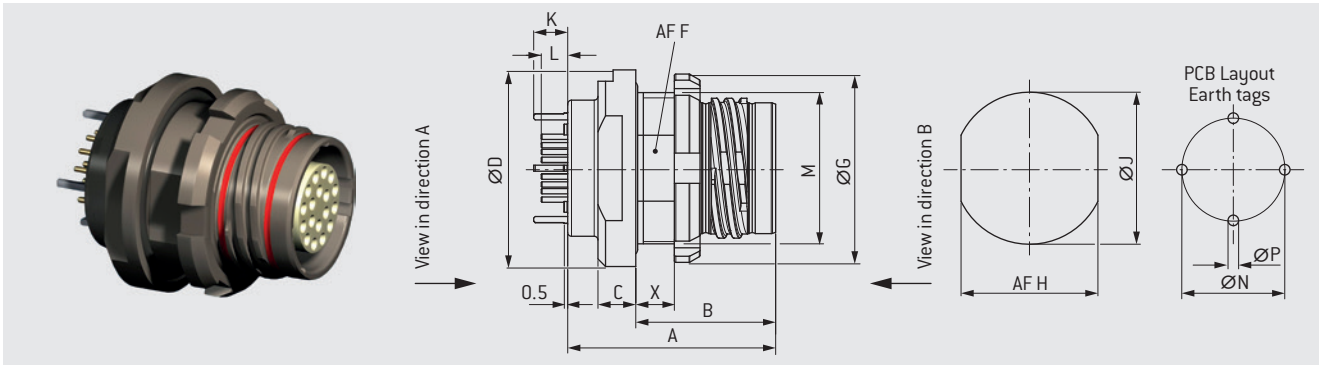

Size	A	B	C	ØD	AFF	ØG	AF H	ØJ	K	L	M	ØN	ØP	X max.
1.5	20.5	14	4	18.9	13	17.9	13.1	14.1	3.5	2.2	M14 × 0.75	9.7	1.2	4
3	27.5	18.5	5	26	18	24.9	18.1	20.1	4.5	4.2	M20 × 1.00	13.6	1.4	5.1

Available codings: brown and red

CONTACT CONFIGURATIONS

Size	Layout viewed from direction A	Number of print contacts	Max. current [A] single contact load	DWV voltage ¹ [VAC]	Suitable for	PCB Layout Only Contacts viewed from direction B
1.5		10 × socket	5	1200	Signal	
		19 × socket	2	1000	Signal	
		8 × socket	5	1200	CAT 5 ² Gigabit Ethernet ²	
3		4 × pin	20	1650	Power	
		2 × pin	30	1350	Power	
		3 × socket	5	1350	Signal	
		18 × socket	7	1200	Signal	
	26 × socket	5	1000	Signal		

Notes: Consult factory for availability. For various applications, the safety requirement regarding the operating voltage is even more severe. This must be evaluated during the time of equipment engineering.

¹ Consult factory for additional information and options.

² These ODU specific connectors can transmit common data transmission protocols such as Ethernet and CAT 5, but they are not Ethernet- or CAT-standard connectors.

RECEPTACLE STYLE 6 – SOLDER CUP

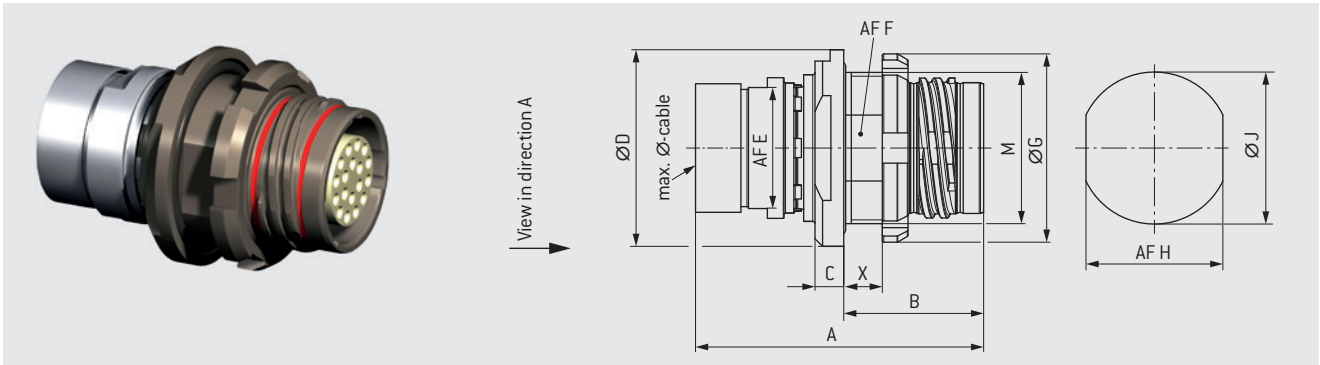

Size	A	B	C	ØD	AFE	AFF	ØG	AFH	ØJ	M	X max.	Max. Ø-cable
1.5	30.3	13	4	18.9	11	13	17.9	13.1	14.1	M14 × 0.75	3	8.5
3	38.1	18.5	5.3	26	16	18	24.9	18.1	20.1	M20 × 1.00	5.1	12.5

Available codings: brown and red

CONTACT CONFIGURATIONS

Size	Layout viewed from direction A	Number of solder contacts	Max. current [A] single contact load	DWV voltage ¹ [VAC]	Max. wire size solder cup	Suitable for
1.5		10 × socket	5	1200	10 × AWG 22	Signal
		19 × socket	2	1000	19 × AWG 26	Signal
		8 × socket	5	1200	8 × AWG 22	CAT 5 ² Gigabit Ethernet ²
3		4 × pin	20	1650	4 × AWG 14	Power
		2 × pin	30	1350	2 × AWG 12	Power
		3 × socket	5	1350	3 × AWG 22	Signal
		18 × socket	7	1200	18 × AWG 20	Signal
	26 × socket	5	1000	26 × AWG 22	Signal	

Notes: Consult factory for availability. For various applications, the safety requirement regarding the operating voltage is even more severe. This must be evaluated during the time of equipment engineering.

¹ Consult factory for additional information and options.

² These ODU specific connectors can transmit common data transmission protocols such as Ethernet and CAT 5, but they are not Ethernet- or CAT-standard connectors.

IN-LINE RECEPTACLE – SOLDER CUP

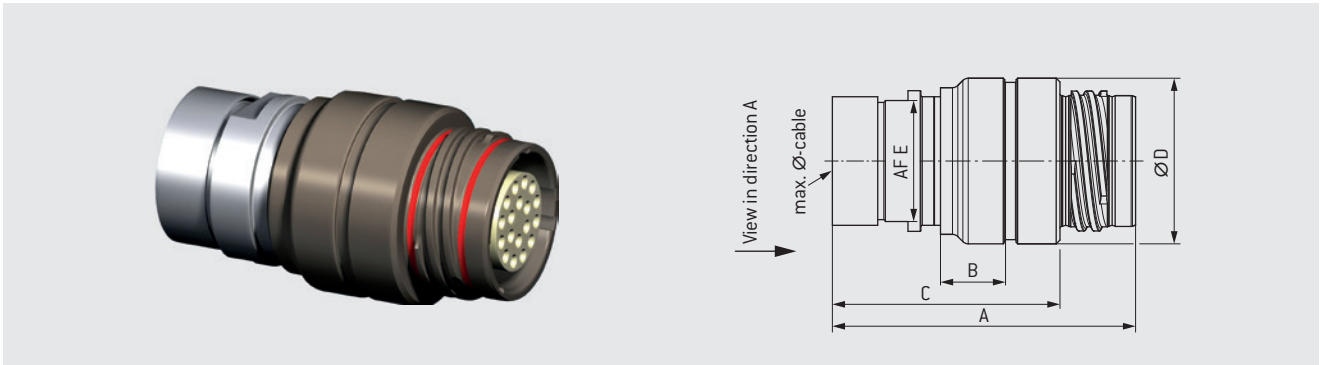

Size	A	B	C	ØD	AFE	Max. Ø-cable
1.5	32.3	12	25.3	15.6	11	8.5
3	40.1	15.8	30.1	21.9	16	12.8

Available codings: brown and red

CONTACT CONFIGURATIONS

Size	Layout viewed from direction A	Number of solder contacts	Max. current [A] single contact load	DWV voltage ¹ [VAC]	Max. wire size solder cup	Suitable for
1.5		10 × socket	5	1200	10 × AWG 22	Signal
		19 × socket	2	1000	19 × AWG 26	Signal
		8 × socket	5	1200	8 × AWG 22	CAT 5 ² Gigabit Ethernet ²
3		4 × pin	20	1650	4 × AWG 14	Power
		2 × pin	30	1350	2 × AWG 12	Power
		3 × socket	5	1350	3 × AWG 22	Signal
		18 × socket	7	1200	18 × AWG 20	Signal
	26 × socket	5	1000	26 × AWG 22	Signal	

Notes: Consult factory for availability. For various applications, the safety requirement regarding the operating voltage is even more severe. This must be evaluated during the time of equipment engineering.

¹ Consult factory for additional information and options.

² These ODU specific connectors can transmit common data transmission protocols such as Ethernet and CAT 5, but they are not Ethernet- or CAT-standard connectors.

PROTECTIVE CAPS

FOR THREADED CONNECTOR RECEPTACLES

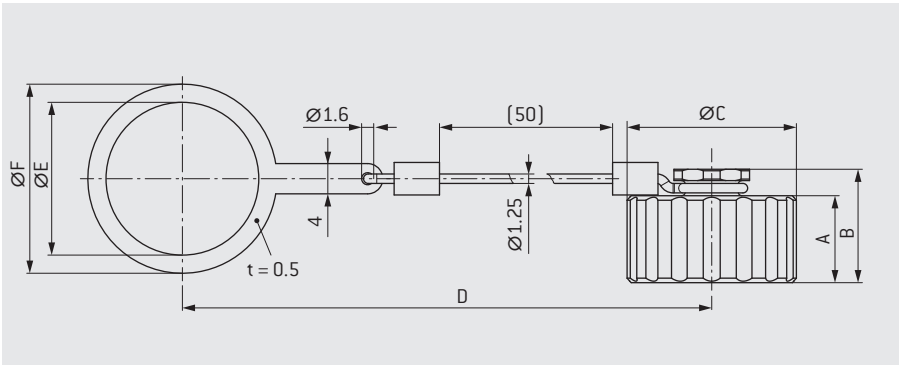

Size	A	B	ØC	D	ØE	ØF
1.5	8.5	12	16	90	14.1	18
3	11.5	15	22.5	100	20.2	25

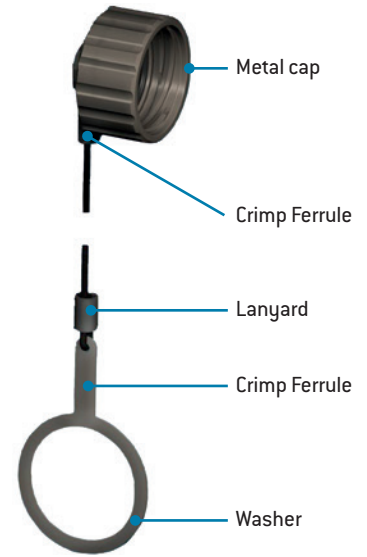

FOR THREADED CONNECTOR PLUGS

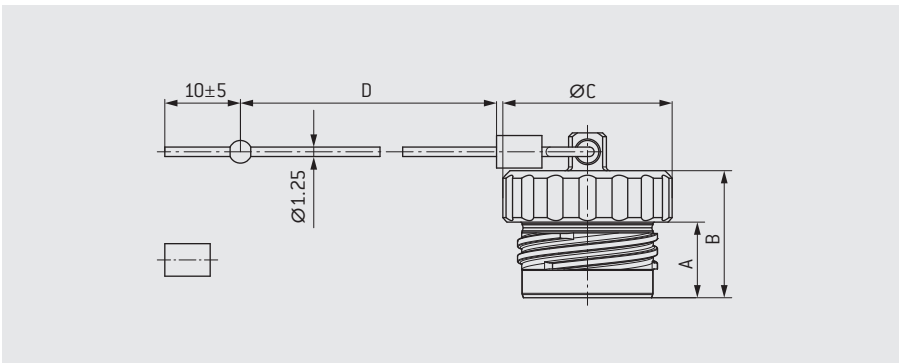

Size	A	B	ØC	D
1.5	13	18	16	200
3	16.8	21.8	22.5	200

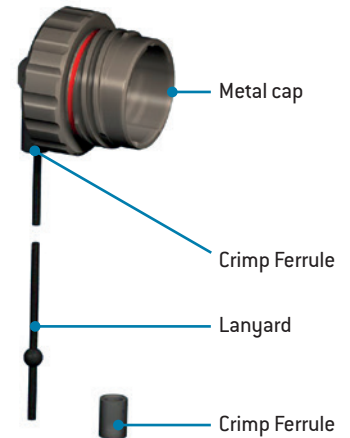

MATERIALS AND SURFACES

Part	Materials and surfaces
Cap	Aluminum / Anthracite Tin-nickel over nickel
Lanyard	Aramid / black
Crimp ferrule	Brass, copper / Zinc-nickel, black
Washer	Brass, copper / Anthracite Tin-nickel over nickel

ENVIRONMENTAL CHARACTERISTICS

Type	Performance
Tightness	IP68 (1m / 120 min)
Operating temperature	-51°C up to +125°C

CABLE ASSEMBLY CAPABILITIES



ODU also offers a comprehensive assembly service. From connector, cable and cable overmolding to watertight potting –

we supply your complete system from one source.

OVERMOLDING

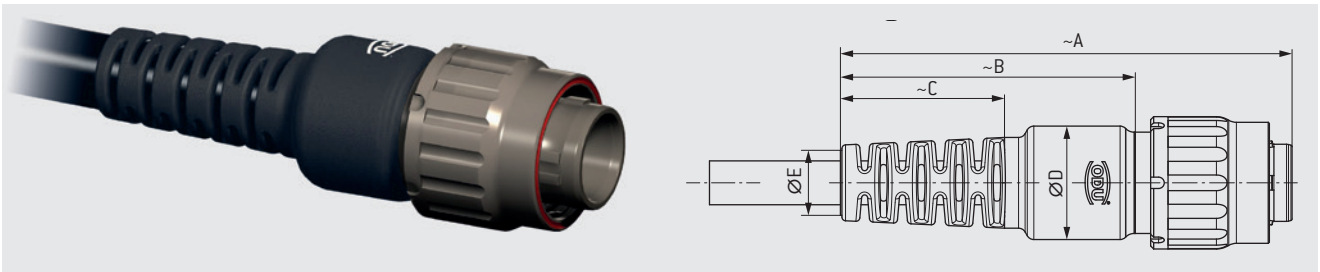

Size	A	B	C	$\varnothing D$	$\varnothing E$	Max. \varnothing -cable
1.5	60	39	21.5	15	10	8.5
3	82	54	29	21.9	13	< 11
					17.5	11 – 12.8

The ODU Threaded Connectors are designed for overmolding. A straight overmolding is available. If you need special overmoldings, please consult the factory for additional information about customized solutions (e.g. 90 degree). A heatshrinkable bend relief is also possible.

TYPICAL PERFORMANCE ATTRIBUTES

ENVIRONMENTAL

Type	Performance	Standard
Waterproofness	IP68 (1m / 120 min)	MIL-STD-810G w/Change 1:2014 Method 512.6
Sand and dust	Blowing sand and dust, settling dust	MIL-STD-810G w/Change 1:2014 Method 510.6
Operating temperature	-51°C up to +125°C	MIL-STD-810G w/Change 1:2014 Method 501.6
Humidity cyclic	85% up to 95% 28°C up to 71°C	EIA-364-31E:2017 Method V
Corrosion resistance	96h salt mist, 5% salt solution, 35°C	MIL-STD-810G w/Change 1:2014 Method 509.6
Fungus	European and American fungus	MIL-STD-810G w/Change 1:2014 Method 508.7
Solar radiation (sunshine)	Temperature after categories A1	MIL-STD-810G w/Change 1:2014 Method 505.6
Contamination by fluids	Several substances ¹	MIL-STD-810G w/Change 1:2014 Method 504.2

¹ Substances listed at ODU datasheet 009.410.281.001.000

MECHANICAL

Type	Performance	Standard
Mechanical durability	2,000 mating cycles	IEC 60512-9-1: 2010, EIA-364-09D:2018
Vibration, sine	30 g	MIL-STD-202H:2015 method 204, Test condition G
Vibration, random	37.8 g	EIA-364-28F:2011, Condition V, Letter J
Mechanical Shock	300 g	EIA-364-27C:2011, Condition D

ELECTRICAL

Type	Performance	Standard
Contact resistance (Fig 1)	Contact-Ø/resistance Ø 0.5 mm < 5 m0hm Ø 0.7 mm < 4 m0hm Ø 0.9 mm < 4 m0hm Ø 2.0 mm < 3 m0hm Ø 2.5 mm < 1 m0hm	IEC 60512-2-1:2002
Shell resistance (Fig 2)	< 10 m0hm	IEC 60512-2-1:2002
Insulation resistance	> 5,000 M0hm	IEC 60512-3-1:2002

Fig 1

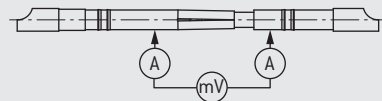
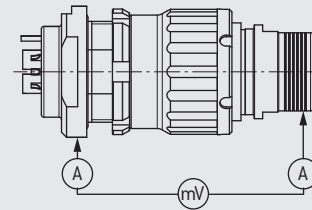

Fig 2



MATERIAL AND SURFACE TREATMENTS

	Material	Standard		Surface	Standard	Flammability
		EU	US			
Housing / nut	Aluminum AlMgSiSn1Bi	EN-AW 6023		Anthracite Tin-nickel over nickel		
Backshell	Aluminum AlMgSiSn1Bi	EN-AW 6023		Nickel	SAE-AMS2404J:2018	
EMI -locking ring	Copper alloy			Gold over nickel		
Crimp sleeve	CuZn38Pb1.5	CW608N (2.0371)	C35300	Nickel		
Grounding ring	CuZn39Pb3	CW614N (2.0401)	C38500	Tin over nickel		
Potting sleeve	PC					
Insulator	PEEK					UL94 (V0)
Pin contact	CuZn39Pb3	CW614N (2.0401)	C38500	1.27 µm Gold over nickel	MIL-DTL-45204D:2007	
Socket contact	CuZn39Pb3	CW614N (2.0401)	C38500	1.27 µm Gold over nickel	MIL-DTL-45204D:2007	
Socket contacts (Power socket contact 5 way size 3)	CuZn39Pb3 (contact body)	CW614N (2.0401)	C38500	1.27 µm Gold over nickel	MIL-DTL-45204D:2007	
	CuBe2 (lamella)	CW102C (2.1248)	C17300	1.27 µm Gold over nickel	MIL-DTL-45204D:2007	
Wave spring	Stainless steel	EN 10270 -3 (1.4568)	S17700			
Ratchet ring	PEEK					UL94 (V0)
O-rings	FVMQ (floursilikon)					
Potting	Potting compound					UL94 (V0)
Overmoulding material	TPU					UL94 (HB)
Shrink boots	Polyester-elastomer					acc. to VG95343

ODU CAPABILITY PORTFOLIO

INGRESS PROTECTION

ODU has the expertise to develop and manufacture interconnect products that satisfy stringent ingress protection requirements. Our knowledge of materials, sealing methods and techniques, supported by FEM simulation, allow our products to go places others cannot.

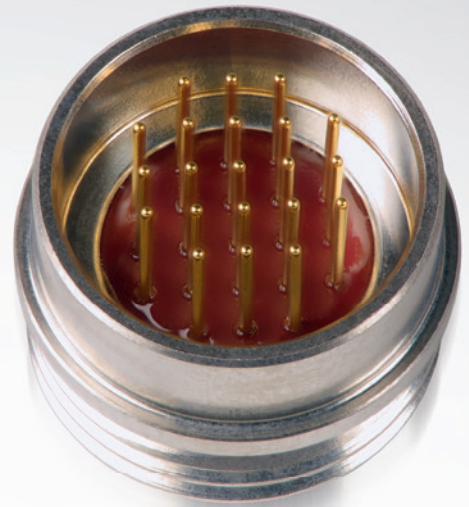
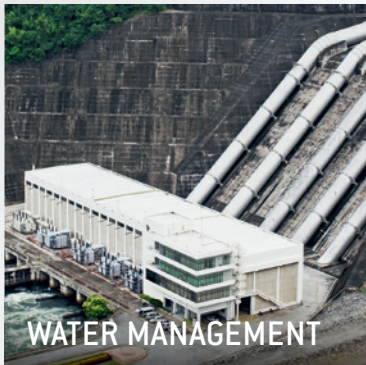

HIGH-SPEED DATA TECHNOLOGY

The volume of data to be transmitted and the electro mechanical requirements of data transmission connectors are growing exponentially. When it comes to high-speed data transfer, these requirements of high-frequency transmission need to be combined in a connector – so the optimal signal integrity has to be ensured throughout the entire product life cycle.

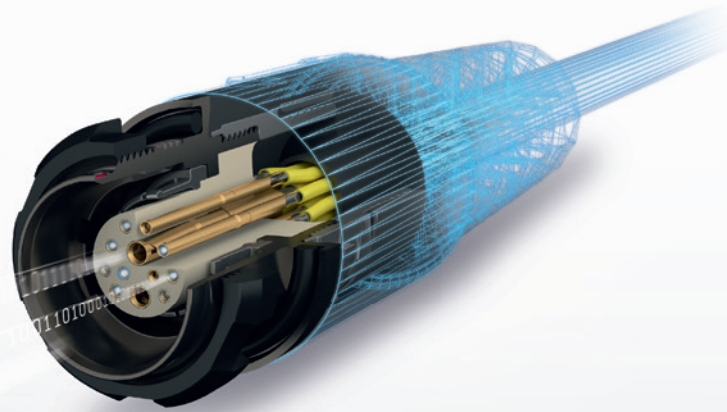



DATA



SIGNALS



FLUIDS



POWER

HYBRID CAPABILITIES

HYBRID CONNECTORS VERSATILE AND EASY TO USE

ODU provides a wide range of custom connector solutions that can accommodate multiple pin-counts and contact combinations. ODU's customer-orientated connector systems ensure a reliable transmission of power, signal, data and media for a large variety of demanding applications. We provide all relevant areas of expertise and key technologies including design and development, machine tool and special machine construction, injection, stamping, turning, surface technology, assembly and cable assembly.

The trends that are driving further development of connector technology include:

- Combined transmission of various media in one interface:
 - electrical (signals, power, data)
 - physical (liquids, gases)
- Low total cost of ownership
- Optimized use of space
- Ease of installation
- High mating cycles
- Small form factor

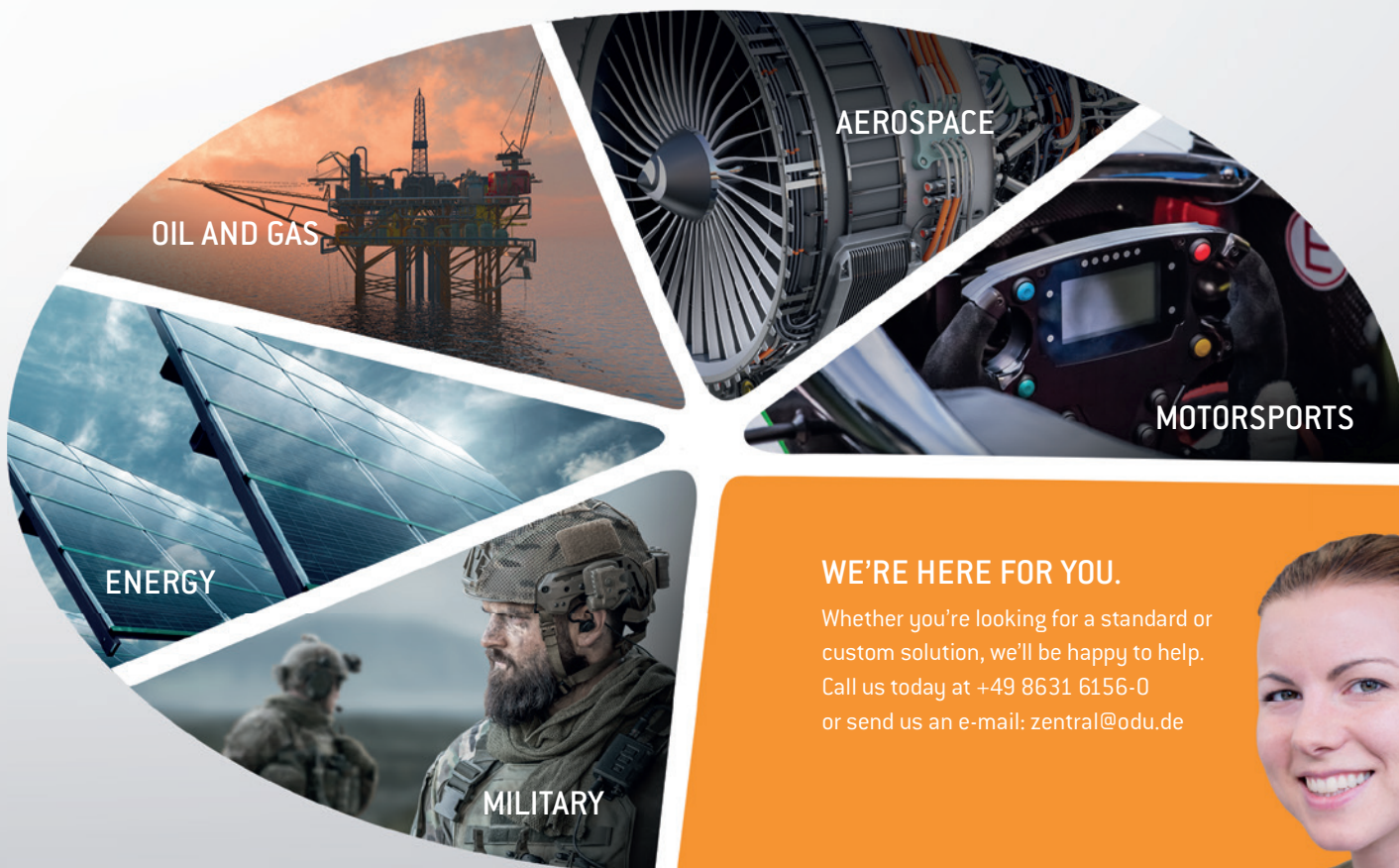
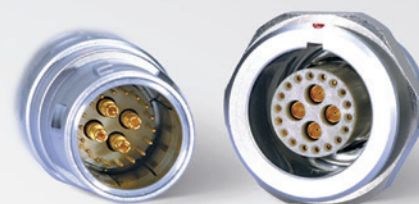

WE'RE HERE FOR YOU.

Whether you're looking for a standard or custom solution, we'll be happy to help. Call us today at +49 8631 6156-0 or send us an e-mail: zentral@odu.de



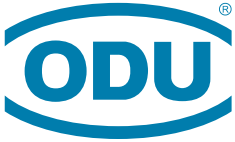

A PERFECT ALLIANCE.

ODU GROUP WORLDWIDE



HEADQUARTERS

ODU GmbH & Co. KG

Pregelstraße 11, 84453 Mühldorf a. Inn, Germany
Phone: +49 8631 6156-0, Fax: +49 8631 6156-49, E-mail: zentral@odu.de

SALES SUBSIDIARIES

ODU Denmark ApS

Phone: +45 2233 5335
E-mail: sales@odu-denmark.dk
www.odu-denmark.dk

ODU Japan K.K.

Phone: +81 3 6441 3210
E-mail: sales@odu.co.jp
www.odu.co.jp

ODU-UK Ltd.

Phone: +44 330 002 0640
E-mail: sales@odu-uk.co.uk
www.odu-uk.co.uk

ODU France SARL

Phone: +33 1 3935-4690
E-mail: odu@odu.fr
www.odu.fr

ODU Scandinavia AB

Phone: +46 176 18262
E-mail: sales@odu.se
www.odu.se

ODU-USA, Inc.

Phone: +1 805 484-0540
E-mail: sales@odu-usa.com
www.odu-usa.com

ODU Italia S.R.L.

Phone: +39 331 8708847
E-mail: sales@odu-italia.it
www.odu-italia.it

ODU (Shanghai)

International Trading Co., Ltd.
Phone: +86 21 58347828-0
E-mail: oduchina@odu.com.cn
www.odu.com.cn

Further information and specialized representatives can be found at:

www.odu-connectors.com/contact

PRODUCTION AND LOGISTICS SITES

Germany	Otto Dunkel GmbH
China	ODU (Shanghai) Connectors Manufacturing Co.Ltd
Mexico	ODU Mexico Manufacturing S.R.L. de C.V.
Romania	ODU Romania Manufacturing S.R.L.
USA	ODU-USA, Inc. ODU North American Logistics



Simply scan the QR code
to download the entire brochure.

All dimensions are in mm. Some figures are for illustrative purposes only.
Subject to change without notice. Errors and omissions excepted.
We reserve the right to change our products and their technical specifications at any time in the interest of technical improvement.
This publication supersedes all prior publications. This publication is also available as a PDF file that can be downloaded from www.odu-connectors.com

KOMMA Werkzeug GmbH | Mühldorf a. Inn

ODU THREADED CONNECTORS

ODU THREADED CONNECTORS / 18 / 0918 / E