

ODU MINI-SNAP® PC



A perfect alliance.

Miniature Circular Connectors with Push-Pull Locking in Plastic

Clarke & Severn Electronics Ph +612 9482 1944 Email sales@clarke.com.au www.cseonline.com.au



Miniature Circular Connectors with Push-Pull Locking in Plastic



Applications:

- Medical
- Industrial
- Measurement and testing
- Military and security
- Energy
- Automotive

Properties:

- Fast and easy mating and demating
- Blind mating and demating in hard-to-access places easily possible
- Low space requirements on the devices
- Clear and reliable locking states
- IP 50 and IP 67
- Shielded model available
- 100% protection against contact
- Easy cleaning of the housing possible

All shown connectors are connectors without breaking capacity (COC) in accordance with DIN EN 61984:2009.

All dimensions are in mm. Some of the pictures are illustrations. Product data and specifications are subject to change without notice.

ODU MINI SNAP connectors are UL-listed under File E110586 00RT03566.
Tested to MIL (see page 77).

Issue 2013-12

Table of Contents (Part I)

Kapitel		ab Seite	
1	Product description ODU MINI-SNAP® PC	5	
	The ODU MINI-SNAP family of miniature circular connectors features Push-Pull locking	6	
	Important issues at a glance, turned contacts	7	
	Contact technology	8	
	Compatibility	9	
2	Series IP 50	11	
3	Series IP 50, EMC protection	17	
4	Series IP 67	23	
5	Series IP 67, EMC protection	29	
6	Inserts	35	
7	Accessories	57	
	Cable band relief made of silicon, protective caps	58	
8	Tools	61	
	Crimping tools for stamped contact	62	
	Crimping tool and contacting for turned contacts	64	
	Crimp accessories and processing information for turned contacts	65	
	Spanner wrench	66	
9	Assembly instruction	66	
	Available assembly instruction	66	

Table of Contents (Part II)

Kapitel		ab Seite	
10	Technical information	67	
	International protection (IP) classes DIN EN 60 529	68	
	Housing materials / surfaces, insulation body material	69	
	Termination technology	70	
	Conversions AWL – cross section	71	
	Current load of stamped contacts	72	
	Current load of turned contacts	73	
	Operating voltage acc. to SAE AS 13441-method 3001.1	74	
	Electromagnetic compatibility (EMC)	75	
	Autoclaving of ODU MINI-SNAP PC connectors	76	
	Test standard	77	
	Technical information / definitions / terms	78	
11	Company information	81	
	Quality management	82	
	Your partner in many application areas	83	
	Overview – all Push-Pull connector series from ODU	84	
	The complete ODU product range	85	
	Everything from one source: ODU – the system supplier	86	
	Application specific connectors	87	
12	Telefax inquiry	89	
13	The part number key	90	

Product Description ODU MINI-SNAP® PC



The ODU MINI-SNAP® Family of Miniature Circular Connectors Features Push-Pull Locking

Circular connectors are generally available with several locking mechanisms.

The most frequently used are

- Threaded-locking sleeve
- Bayonet-locking
- Push-Pull locking

Push-Pull connectors have a very simple locking mechanism

- As the plug is pushed into the receptacle, locking fingers on the plug snap into the receptacle creating a reliable connection between plug and receptacle.
- Pulling on the cable or the rear of plug causes the locking fingers to grab harder and a separation of plug and receptacle is almost impossible. Pulling on the outer plug housing causes the locking fingers to retract and the plug and receptacle separate easily.



Important Issues at a Glance

Certification

The series is certified acc. and 2011/65/EC .

3 sizes

Plastic housing available in 3 sizes. Outside diameter between 12.5 mm and 19 mm. Number of contact positions: 2 to 27 positions.

Extensive range of termination possibilities

Contacts with solder, crimp and print (PCB) termination.

Degree of protection IP 50 and IP 67 available

Keying using half-shells

Plug compatible with the ODU MINI-SNAP® Series F metal version

High profitability because

- Contacts can be assembled automatically
- Easy crimp contact assembly using clip technique
- Easy plug assembly
- Economical prices

Further advantages:

- Housing with 100% protection against contact
- Light
- Low mating forces
- Housing A-magnetic
- Very high chemical resistance
- Shielded version available

Applications

	Insulation body material	Contact material
	PEEK	Ms
General application requirements (-40° C to +120° C)	●	●
Connectors which are autoclavable (+134° C, see page 76)	●	●

Termination style

	Insulation body material	Contact material
	PEEK	Ms
Crimp termination	●	●
Solder termination	●	●
Printed circuit board (PCB) termination	●	●

Turned Contact

Turned contacts are available in the diameters 0.5 to 4.0 mm. The contacts are available with following terminations: **Solder, crimp and print (PCB).**

Mating cycles > 5,000
 Material Brass
 Treatment processing Ni; Au on the mating area

For information regarding diameter, termination style and current load please see the contact configuration section.

Termination standard pin contacts

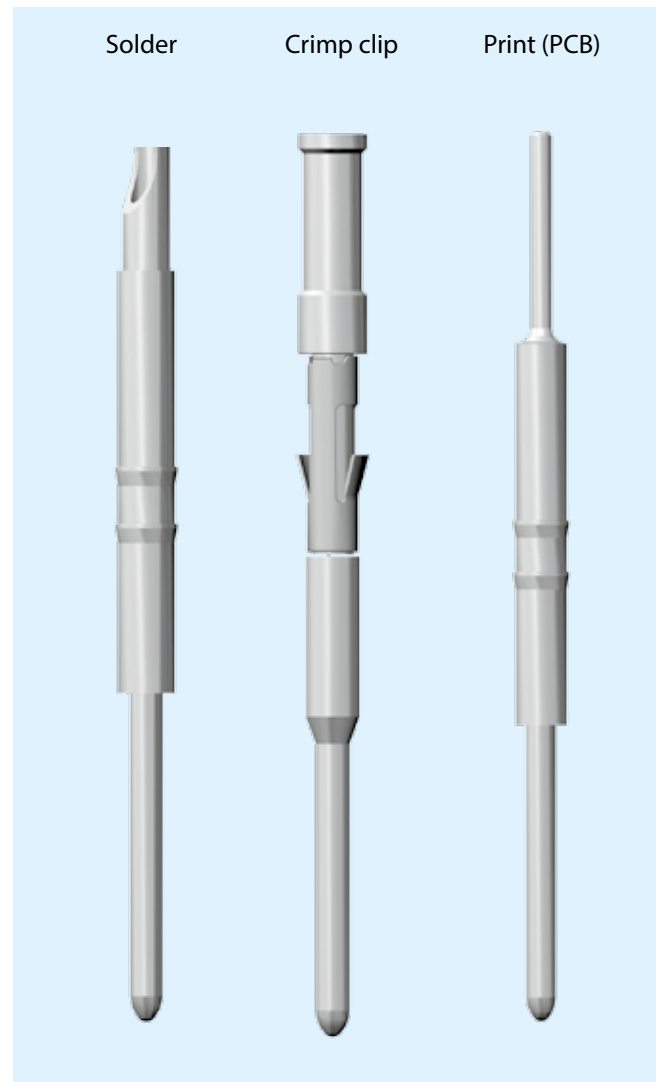

Contact Technology

It is possible to use stamped or turned contacts in the insulator with the ODU MINI-SNAP® PC. Stamped contacts offer primarily economic advantages with regard to both the part price and the total costs for assembly. Stamped contacts are delivered as coiled stamped strips and so can be economically, semi-automatically assembled.

The advantages of the turned contacts are seen in the processing of small quantities (e.g., by soldering) and the higher current-carrying capacity of the individual contacts. Subsequent extrusion of the connector is also possible with solid contacts only. The diagrams show a comparison of the contact technologies.

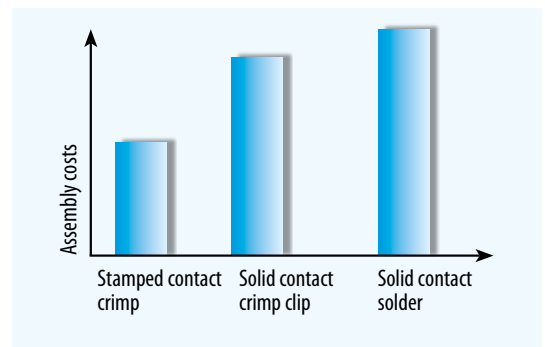
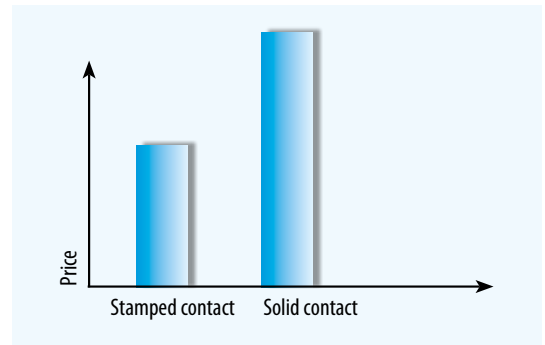
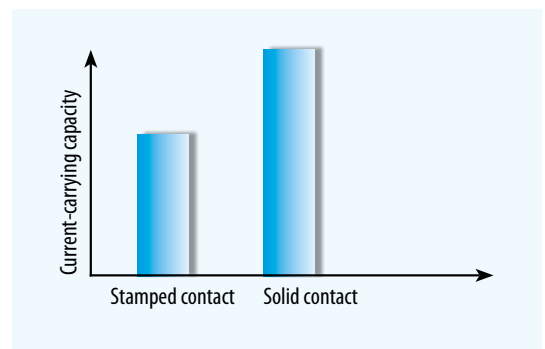
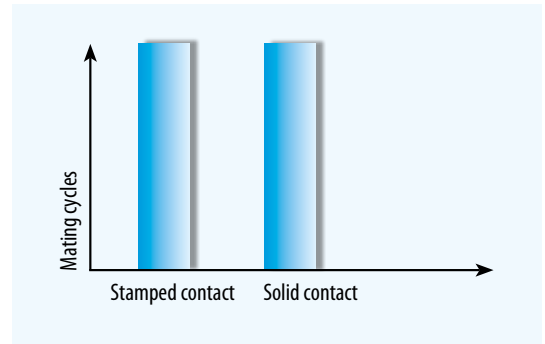

Compatibility

Connection compatibility

The ODU MINI-SNAP® PC is plug-compatible with the metal version in the F series. Tightness between MINI-SNAP PC Version IP 67 and MINI-SNAP F series Version IP 68 is not ensured, however.

Insert exchangeability

The ODU MINI-SNAP PC is an enhancement and supplement of the ODU MINI-SNAP metal version, and so all inserts from the metal version's F and B series in sizes 1, 2 and 3 can be used in the ODU MINI-SNAP PC.

There are currently roughly 100 different contact arrangements available.

ODU MINI-SNAP PC: Available versions

- IP 50
- IP 50 + EMC protection
- IP 67
- IP 67 + EMC protection

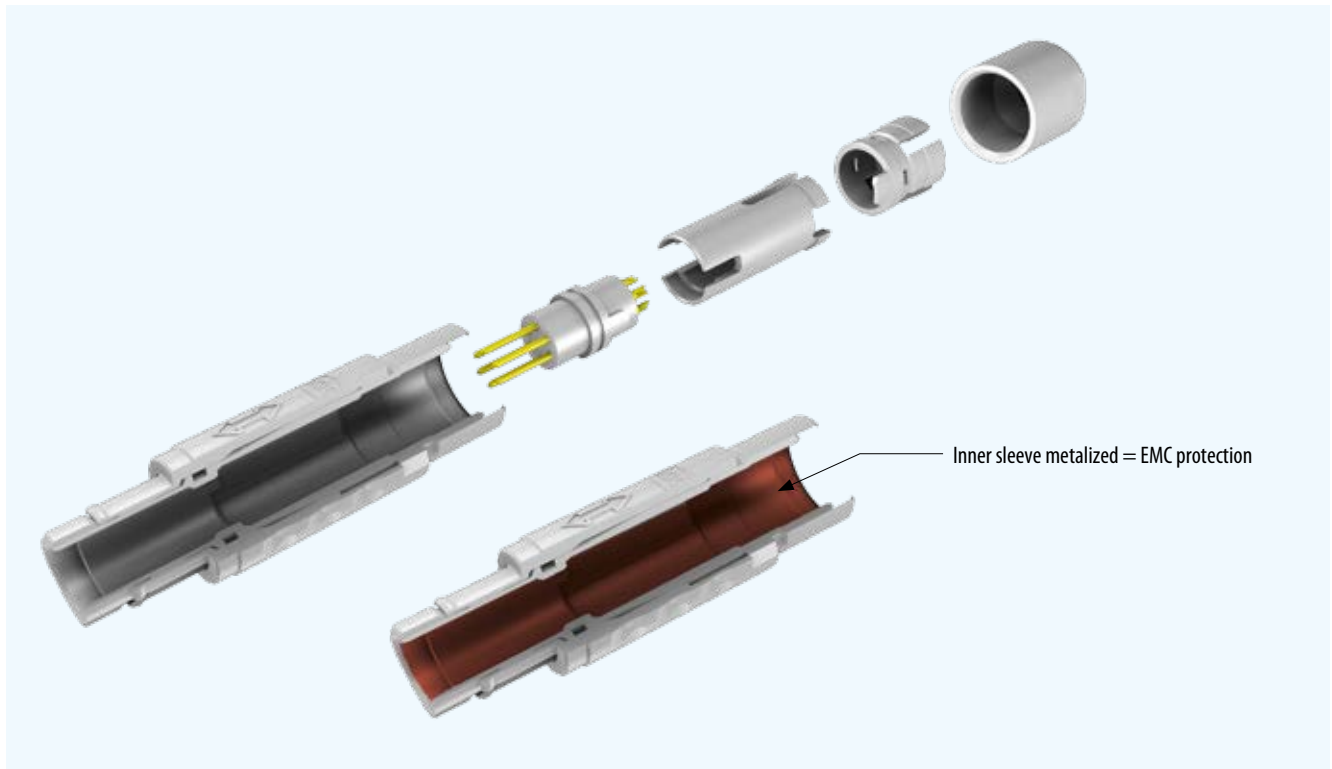



Protection Class IP 50



Straight Plug – IP 50

Connector type

1	2	3	4	5	6	7	8	9	10	11	12	13	14	15	16	17	18	19
			A			-								-				0

S 1 0

Style 1: IP 50, with standard back nut

S 2 S

Style 2: IP 50, with back nut for cable bend relief¹⁾

Size	Dimensions in mm				
	L1	L2	D	SW A	SW B
1	~ 46	~ 35	12.5	11	11
2	~ 52	~ 40	15.7	14	14
3	~ 60	~ 45	18.7	16	17

Technical data

– Contact configuration see page 38

¹⁾ Cable bend reliefs have to be ordered separately (see page 58)

Receptacle

Connector type

1	2	3	4	5	6	7	8	9	10	11	12	13	14	15	16	17	18	19	
			A			-									-	0	0	0	0

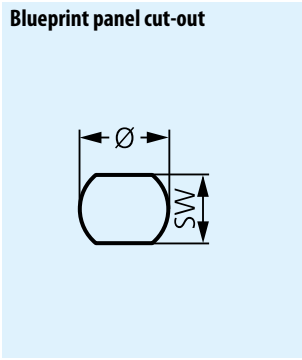
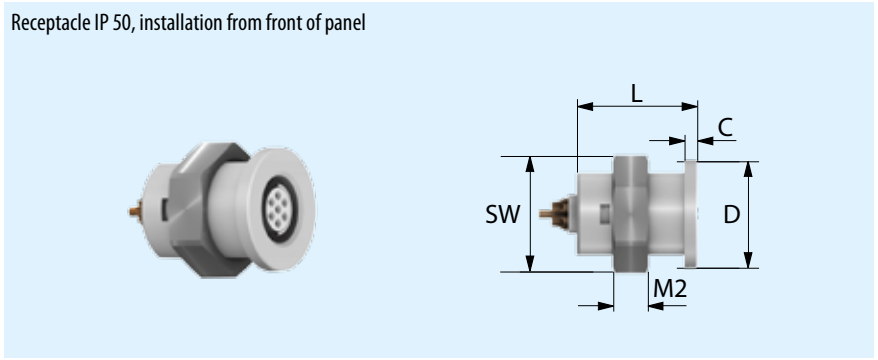

Size	Dimensions in mm					Panel cut-out	
	L	D	C	M2	SW	SW	Ø
1	18.5	16.5	2.0	5.5	16.0	12.6	13.6
2	20.5	21.0	2.0	5.5	19.0	15.6	16.6
3	25.0	24.5	2.0	5.5	24.0	19.1	21.1

- Technical data**
- IP50 in mated condition
 - Anti-rotation feature
 - Contact configuration see page 38
 - Minimum housing wall thickness: 1 mm

Receptacle

Connector type

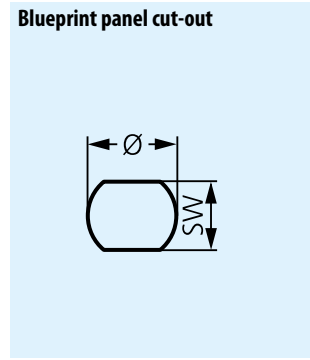
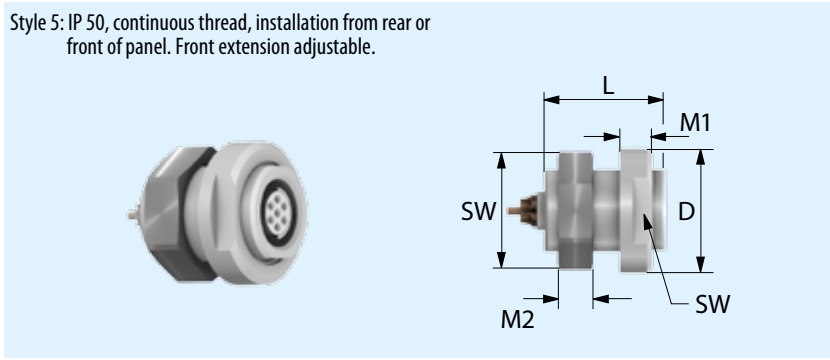
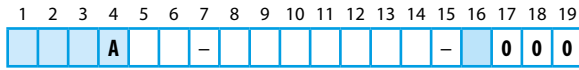

Size	Dimensions in mm					Panel cut-out	
	L	D	M1	M2	SW	SW	Ø
1	18.5	19.0	5.0	5.5	16.0	12.6	13.6
2	20.5	21.5	5.0	5.5	19.0	15.6	16.6
3	25.0	28.0	5.0	5.5	24.0	19.1	21.1

- Technical data**
- IP 50 with respect to the seal of the end device
 - Anti-rotation feature
 - Contact configuration see page 38

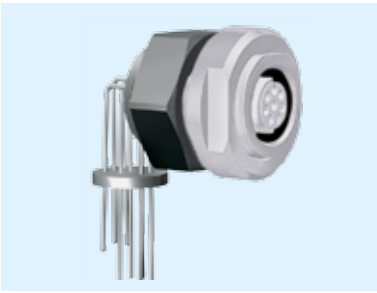

Right-Angled Print Contacts

- Only for receptacle style 5
- Only for turned contacts

In-line Receptacle – IP 50

Series IP 50

Connector type

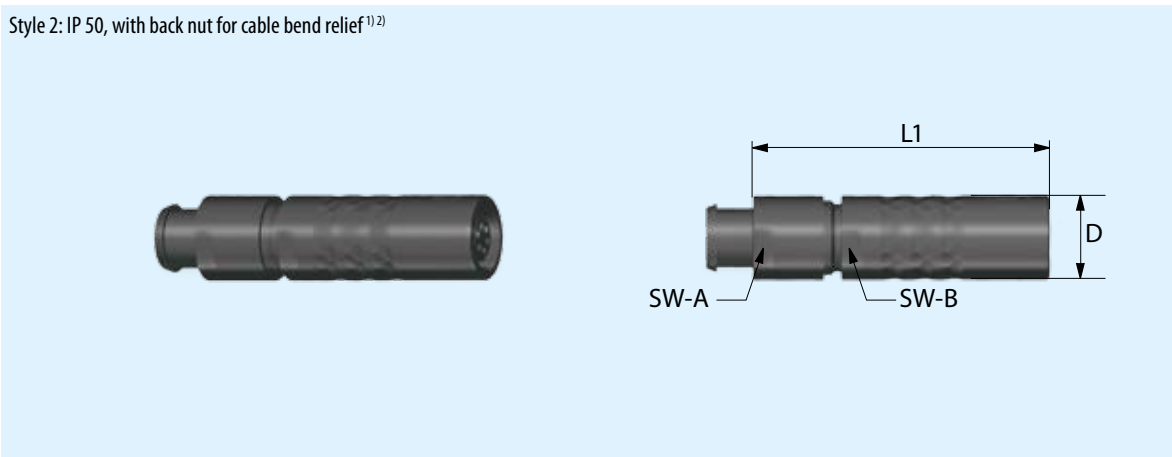
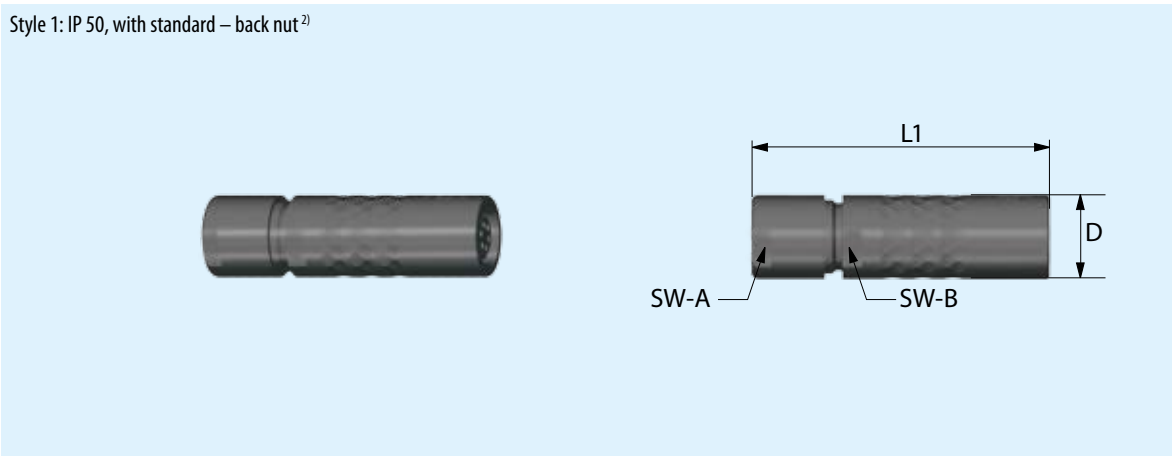
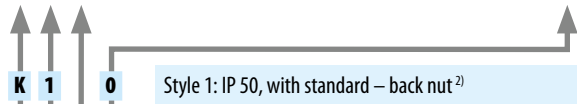
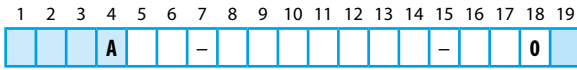

		Dimensions in mm			
	Size	L1	D	SW A	SW B
1	1	~ 45	12.5	11	11
2	2	~ 50	15.7	14	14
3	3	~ 58	18.7	16	17

¹⁾ Cable bend relief order separately (see page 58)

²⁾ Available with black housing only

Keying Possibilities

1	2	3	4	5	6	7	8	9	10	11	12	13	14	15	16	17	18	19	
					-										-				

Keying	Receptacle front view	Size			Remark
		1	2	3	
1		●	●	●	
2		●	●	●	
9		●		●	1)

Housing Materials

1	2	3	4	5	6	7	8	9	10	11	12	13	14	15	16	17	18	19	
						-									-				

Housing materials	Housing material
G	Plastic, grey (similar to 7035)
S	Plastic, black (similar to 9004)
W	Plastic, white (similar to 9002)

1) not compatible with ODU MINI-SNAP® F series

Plastic Cable Collet for Connector and In-line Receptacle

Collet system

1	2	3	4	5	6	7	8	9	10	11	12	13	14	15	16	17	18	19	
						-									-				

Cable diameter in mm	Size			Cable collet system	Cable collet system
	1	2	3		
> 1.5 – 2.5	●			2	5
> 2.5 – 3.7	●			3	7
> 3.1 – 4.5		●		4	5
> 3.7 – 4.9	●			4	9
> 4.6 – 6.0		●	●	6	0
> 4.9 – 6.0	●			6	0
> 6.1 – 7.5		●	●	7	5
> 7.6 – 9.0		●	●	9	0
> 9.1 – 10.5			●	0	2

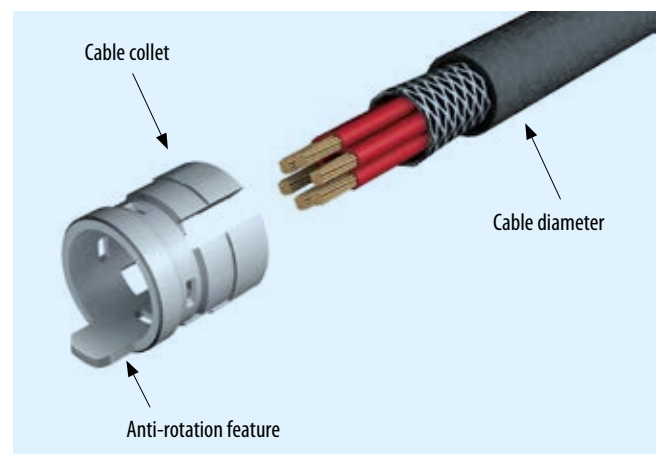

Applications:
 Cable collet for strain relief
 Protecting the connection points when there are pulls on the cable

Protection Class IP 50, EMC Protection



Series IP 50
EMC Protection



Straight Plug – IP50 EMC Protection

Connector type

1	2	3	4	5	6	7	8	9	10	11	12	13	14	15	16	17	18	19	
			C			-									-				0

Type EMC

S

1

0

Style 1: IP 50, with standard – back nut

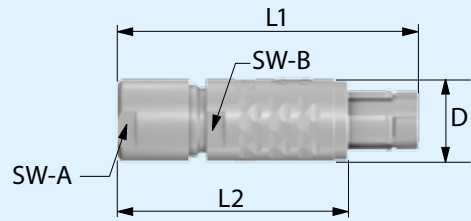

S

2

S

Style 2: IP 50, with back nut for cable bend relief¹⁾

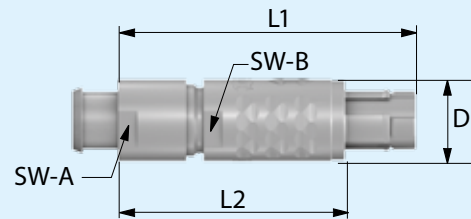

Size	Dimensions in mm					
	L1	L2	D	SW A	SW B	
1	~ 46	~ 35	12.5	11	11	
2	~ 52	~ 40	15.7	14	14	
3	~ 60	~ 45	18.7	16	17	

Technical data

– Contact configuration see page 38

¹⁾ Cable bend reliefs have to be ordered separately (see page 58)

Receptacle – IP50 EMC Protection

Connector type

1	2	3	4	5	6	7	8	9	10	11	12	13	14	15	16	17	18	19	
			C			-									-	0	0	0	0

Type EMC

G 1

Style 1: IP 50, installation from front of panel

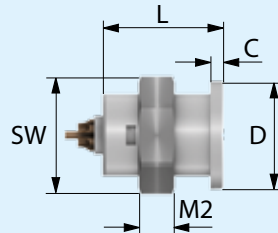
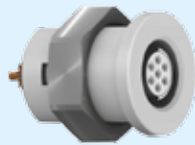

Blueprint panel cut-out

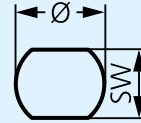

Size	Dimensions in mm					Panel cut-out	
	L	D	C	M2	SW	SW	Ø
1	18.5	16.5	2.0	5.5	16.0	12.6	13.6
2	20.5	21.0	2.0	5.5	19.0	15.6	16.6
3	25.0	24.5	2.0	5.5	24.0	19.1	21.1

Technical data

- IP 50 in mated condition
- Anti-rotation feature
- Contact configuration see page 38
- Minimum housing wall thickness: 1 mm
- Touch-proof when mated

G 5

Style 5: IP 50, continuous thread, installation from rear or front of panel. Front extension adjustable.

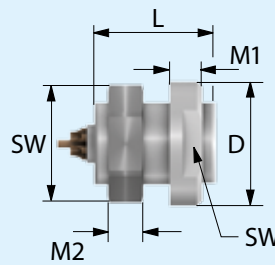
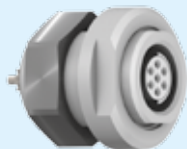

Blueprint panel cut-out

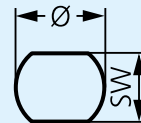

Size	Dimensions in mm					Panel cut-out	
	L	D	M1	M2	SW	SW	Ø
1	18.5	19.0	5.0	5.5	16.0	12.6	7.1
2	20.5	21.5	5.0	5.5	19.0	15.6	16.6
3	25.0	28.0	5.0	5.5	24.0	19.1	21.1

Technical data

- IP 50 in mated condition
- Anti-rotation feature
- Contact configuration see page 38

Keying Possibilities

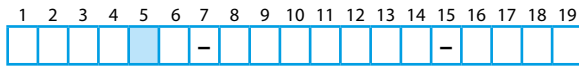

Keying	Receptacle front view	Size			Remark
		1	2	3	
1		●	●	●	
2		●	●	●	
9		●		●	1)

1) not compatible with ODU MINI-SNAP® F series

Housing

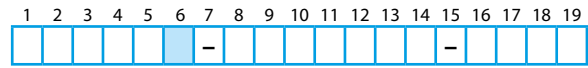

Housing materials	Housing materials
6	Plastic, grey (similar to 7035)

Plastic Cable Collet for Plugs

Collet system

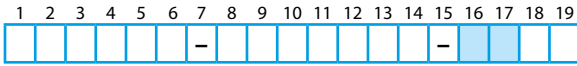

Cable diameter in mm	Size			Cable collet system	Cable collet system
	1	2	3		
> 1.5 – 2.5	●			2	5
> 2.5 – 3.7	●			3	7
> 3.1 – 4.5		●		4	5
> 3.7 – 4.9	●			4	9
> 4.6 – 6.0		●	●	6	0
> 4.9 – 6.0	●			6	0
> 6.1 – 7.5		●	●	7	5
> 7.6 – 9.0		●	●	9	0
> 9.1 – 10.5			●	0	2

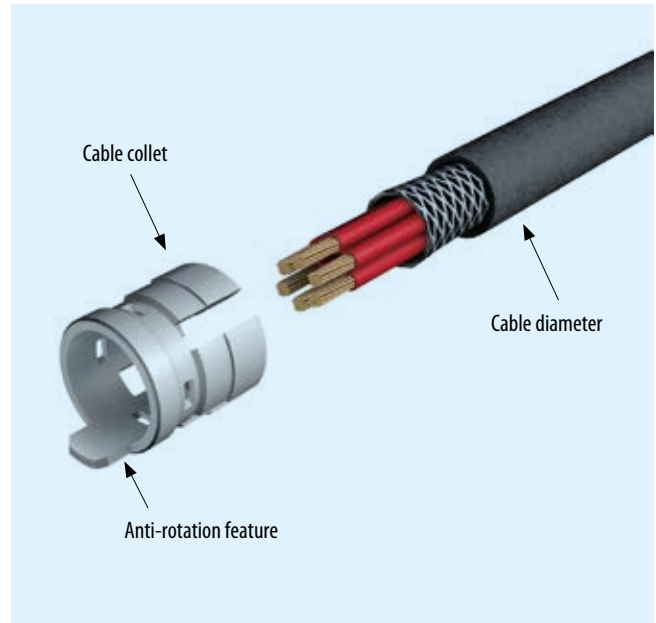

Applications:

- Cable collet for strain relief
- Protecting the connection points when there are pulls on the cable



Protection Class IP 67 (when Mated)



Series IP 67



Straight Plug – IP67

Connector type

1	2	3	4	5	6	7	8	9	10	11	12	13	14	15	16	17	18	19
			A			-								-				0

S 3 0 → Style 3: IP 67, with standard – back nut

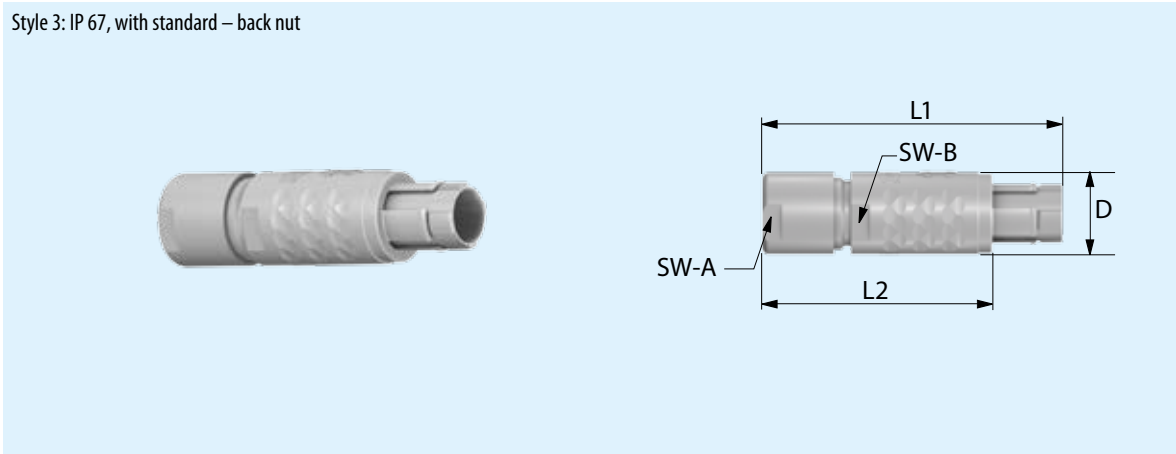

S 4 S → Style 4: IP 67, with back nut for cable bend relief¹⁾

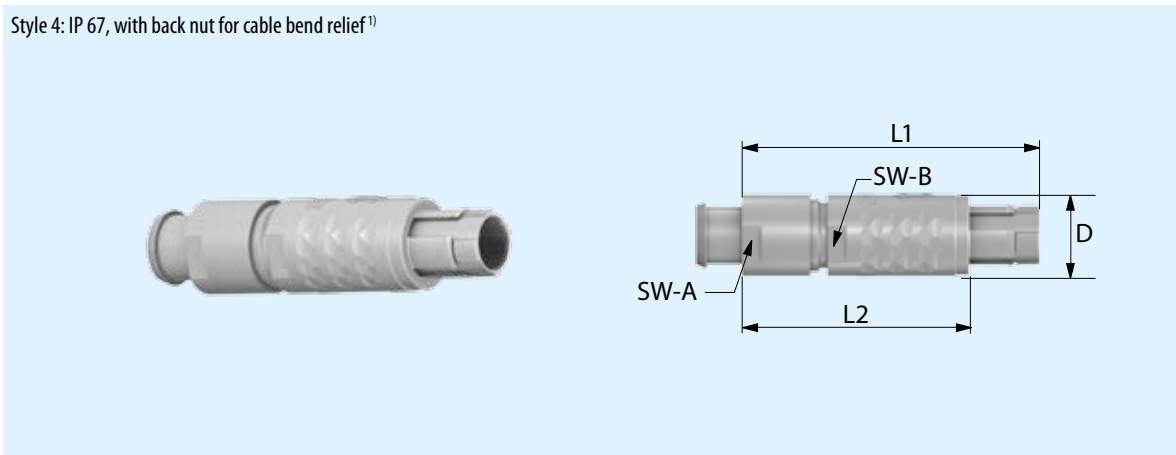

Size	Dimensions in mm					
	L1	L2	D	SW-A	SW-B	
1	1	~ 46	~ 35	12.5	11	11
2	2	~ 52	~ 40	15.7	14	14
3	3	~ 60	~ 45	18.7	16	17

¹⁾ cable bend relief order separately (see page 58)

Receptacle – IP 67 – Style E

Connector type

1	2	3	4	5	6	7	8	9	10	11	12	13	14	15	16	17	18	19	
			A			-									-	0	0	0	0

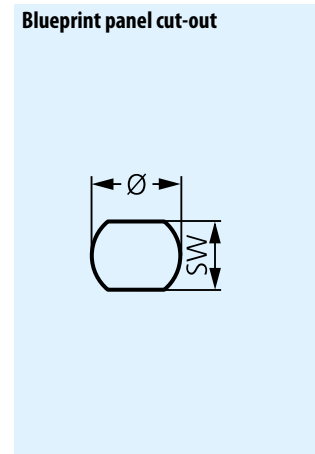
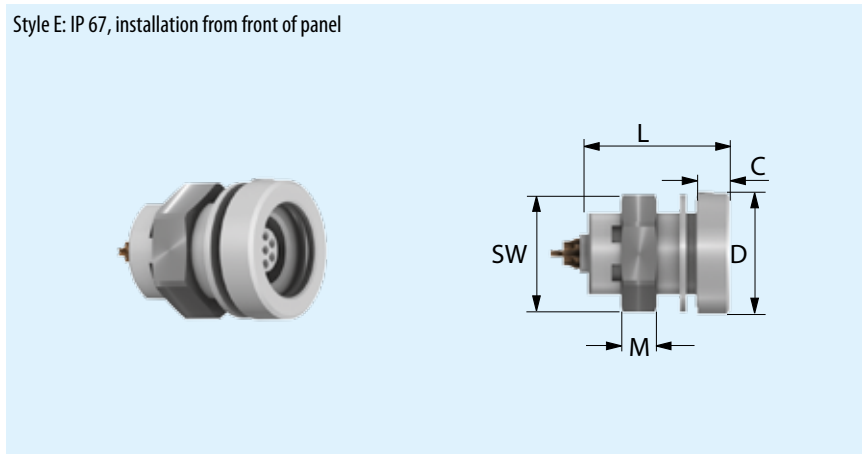

Size	Dimensions in mm					Panel cut-out	
	L	D	C	M	SW	SW	Ø
1	22.0	18.5	~ 6.0	5.5	16.0	12.6	13.6
2	24.0	22.5	~ 6.0	5.5	19.0	15.6	16.6
3	28.5	26.5	~ 6.0	5.5	24.0	19.1	21.1

Technical data

- IP 67 in mated condition
- IP 50 in unmated condition
- Contact configuration see page 38

Series IP 67

In-line Receptacle – IP 67

Connector type

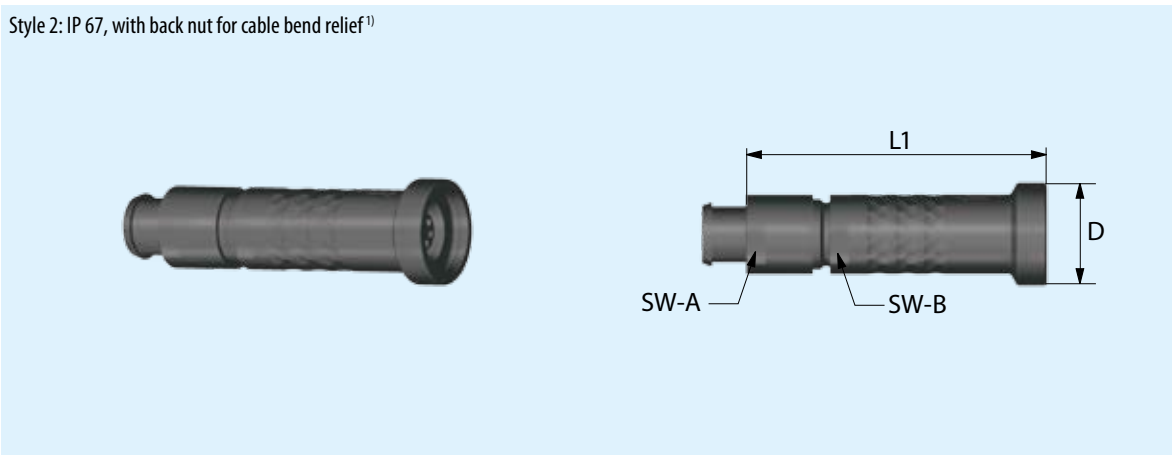
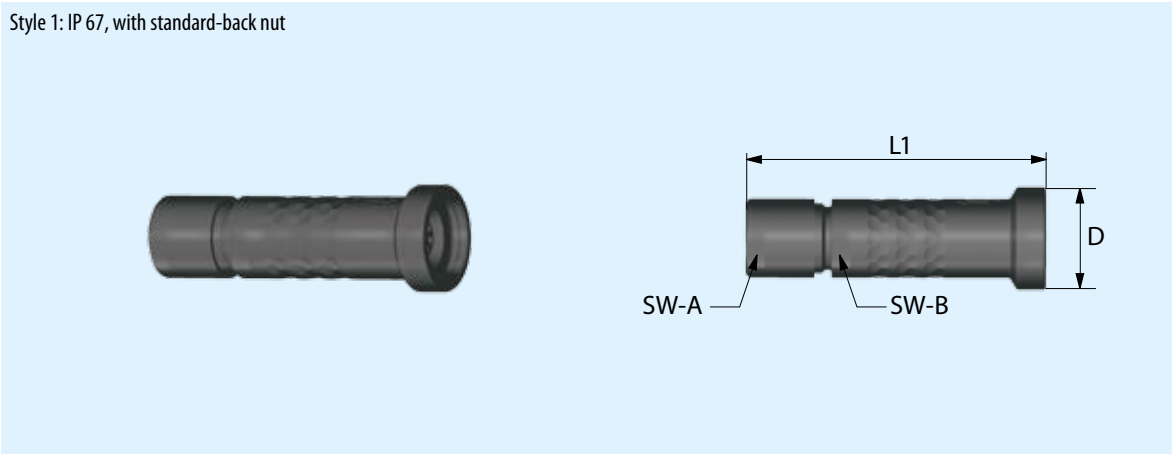
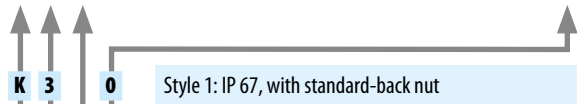
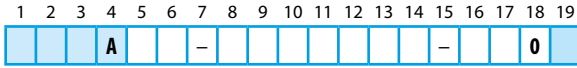

Size	Dimensions in mm			
	L1	D	SW-A	SW-B
1	~ 48	16.2	11	11
2	~ 53	19.8	14	14
3	~ 62	23	16	17

¹⁾ cable bend relief order separately (see page 58)

- Only available with black housing
- Only available in coding 1

Keying Possibilities

Housing Material

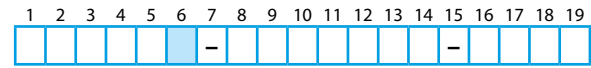
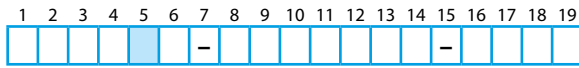

Keying	Receptacle front view	Size			Remark
		1	2	3	
1		●	●	●	
2		●	●	●	
9		●		●	1)

Housing materials	Housing materials	
	G	Plastic, grey (similar to RAL 7035)
S	Plastic, black (similar to RAL 9004)	
W	Plastic, white (similar to RAL 9002)	

1) Not compatible to ODU MINI-SNAP® Series F

Plastic Cable Collet for Plugs

Collet system

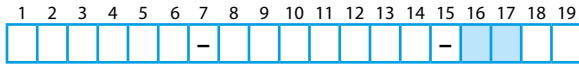

Cable diameter in mm	Size			Collet system	Collet system
	1	2	3		
> 1.5 – 2.5	●			2	5
> 2.5 – 3.7	●			3	7
> 3.1 – 4.5		●		4	5
> 3.7 – 4.9	●			4	9
> 4.6 – 6.0		●	●	6	0
> 4.9 – 6.0	●			6	0
> 6.1 – 7.5		●	●	7	5
> 7.6 – 9.0		●	●	9	0
> 9.1 – 10.5			●	0	2

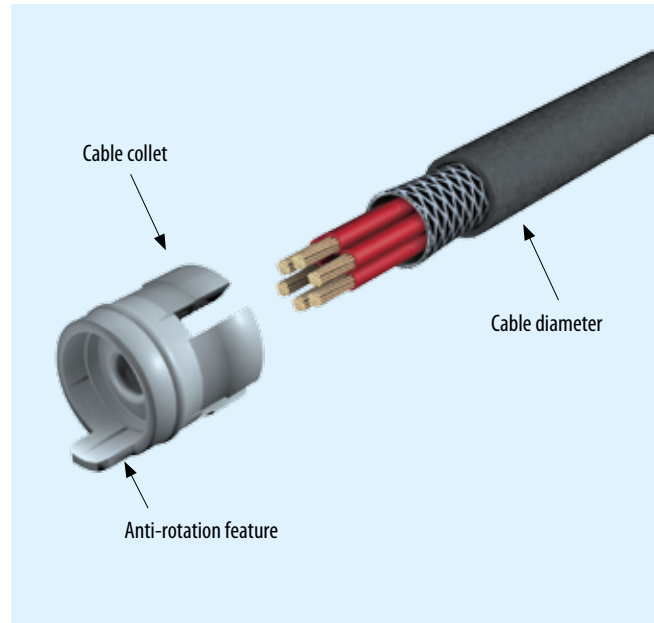

Application:

- Cable collet for strain relief
- Protecting the connection points when there are pulls on the cable
- Seal between cable and connector housing

**Protection Class IP 67,
(in Mated Condition)
EMC Protection**



Series IP 67
EMC Protection



Straight Plug – IP 67 EMC Protection

Connector type

1	2	3	4	5	6	7	8	9	10	11	12	13	14	15	16	17	18	19
			C			-								-				0

S 3 0 → Style 3: IP 67, with standard-back nut

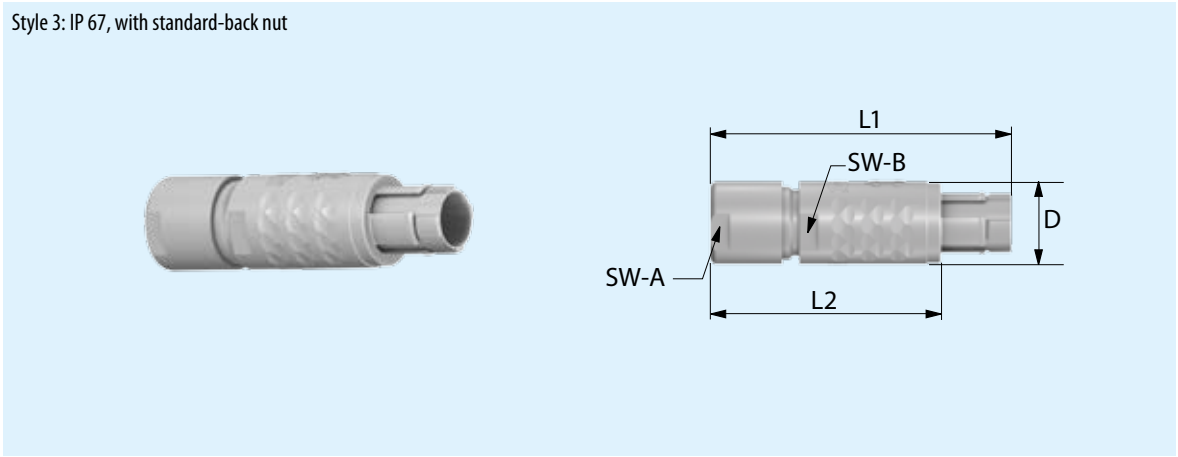

S 4 S → Style 4: IP 67, with back nut for cable bend relief¹⁾

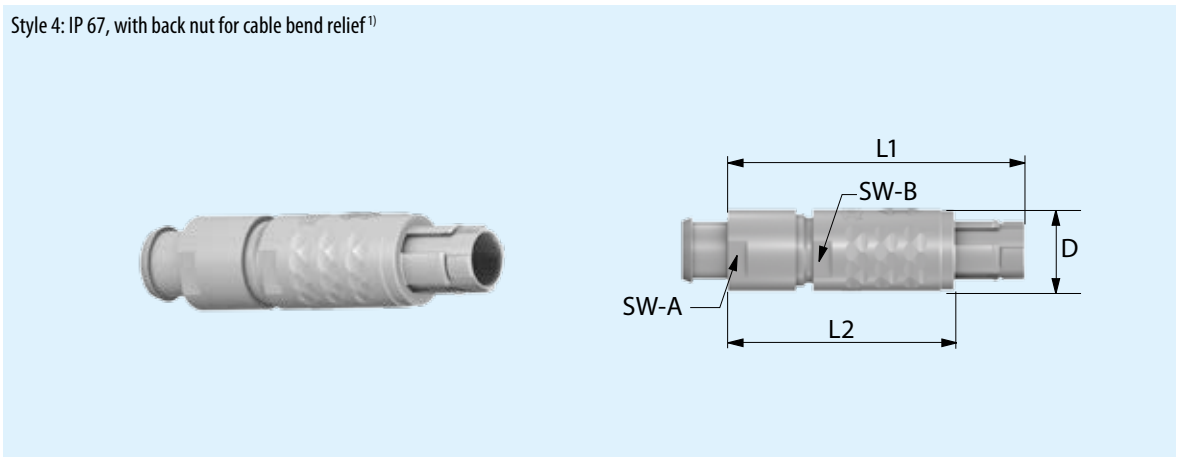

Size	Dimensions in mm					
	L1	L2	D	SW-A	SW-B	
1	~ 46	~35	12.5	11	11	
2	~ 52	~40	15.7	14	14	
3	~ 60	~45	18.7	16	17	

¹⁾ cable bend relief order separately (see page 58)

Receptacle – IP 67 EMC Protection – Style E

Connector type

1	2	3	4	5	6	7	8	9	10	11	12	13	14	15	16	17	18	19
			C			-								-	0	0	0	0

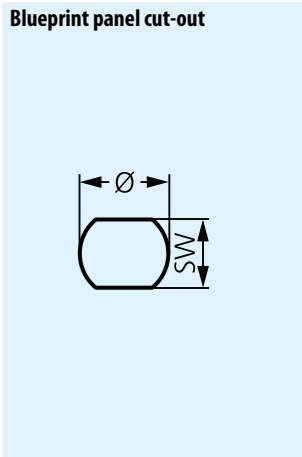
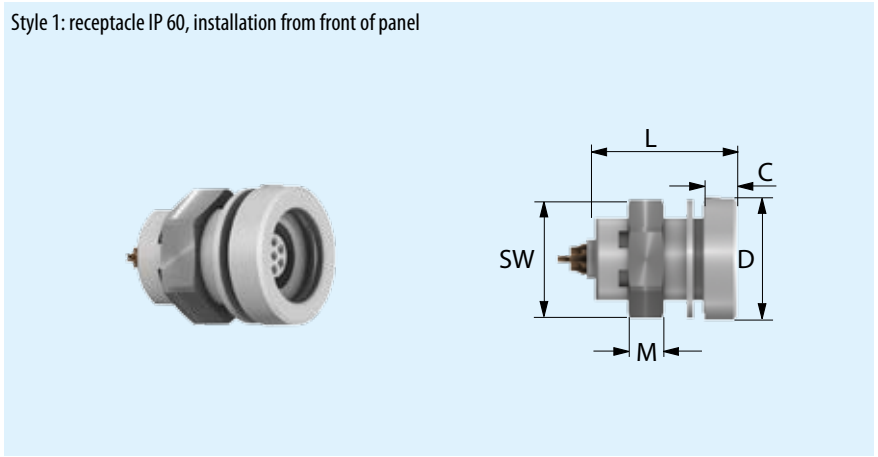

Size	Dimensions in mm					Panel cut-out	
	L	D	C	M	SW	SW	Ø
1	22.0	18.5	~ 6.0	5.5	16.0	12.6	13.6
2	24.0	22.5	~ 6.0	5.5	19.0	15.6	16.6
3	28.5	26.5	~ 6.0	5.5	24.0	19.1	21.1

Technical data

- IP 67 in mated condition
- IP 50 to the panel in unmated condition
- Contact configuration see page 38

Series IP 67
EMC Protection

Keying Possibilities

1	2	3	4	5	6	7	8	9	10	11	12	13	14	15	16	17	18	19	
					-									-					

Keying	Receptacle front view	Size			Remark
		1	2	3	
1		•	•	•	
2		•	•	•	
9		•		•	1)

1) Not compatible to ODU MINI-SNAP® Series F

Housing Material

1	2	3	4	5	6	7	8	9	10	11	12	13	14	15	16	17	18	19	
						-								-					

Housing materials	Housing materials
G	Plastic, grey (similar to RAL 7035)

Plastic Cable Collet for Plugs

Cable collet

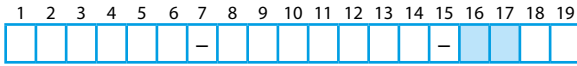

Cable diameter in mm	Size			Collet system	Collet system
	1	2	3		
> 1.5 – 2.5	●			2	5
> 2.5 – 3.7	●			3	7
> 3.1 – 4.5		●		4	5
> 3.7 – 4.9	●			4	9
> 4.6 – 6.0		●	●	6	0
> 4.9 – 6.0	●			6	0
> 6.1 – 7.5		●	●	7	5
> 7.6 – 9.0		●	●	9	0
> 9.1 – 10.5			●	0	2

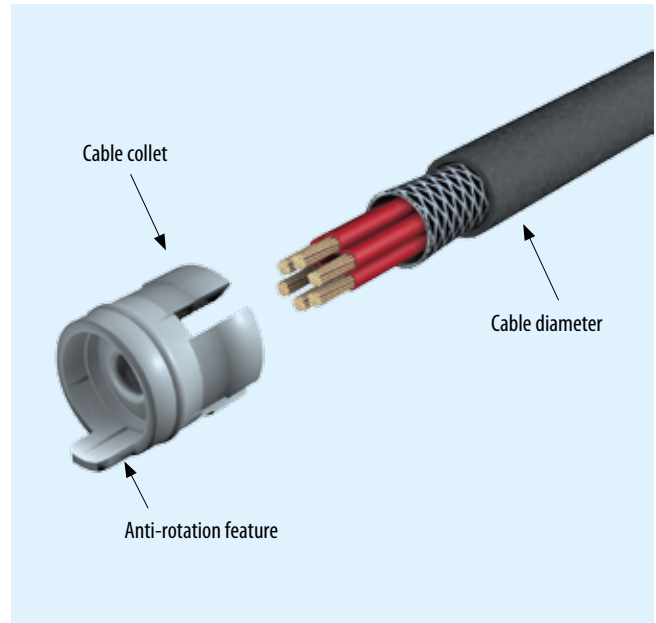

Application:

- Cable collet for strain relief
- Protecting the connection points when there are pulls on the cable
- Seal between cable and connector housing



Inserts



Insulation Body Material

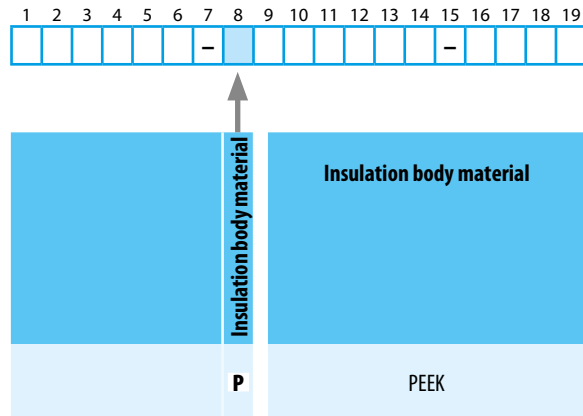

Turned contacts

Termination	PEEK	Remark
Solder	●	Contacts pre-assembled
Crimp with clip	●	Contacts are included in the delivery separately
Print (PCB)	●	Contacts pre-assembled

Stamped contacts

Termination	PEEK	Remark
Solder	●	Contacts pre-assembled
Crimp with clip	●	Contacts are included in the delivery separately
Print (PCB)	●	Contacts pre-assembled







● = Possible combinations

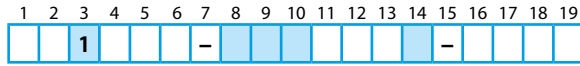

Inserts for Stamped Contacts

Size, number of contacts



Size	Insulation body	Number of contacts	Alignment in use	Contact diameter mm	Nominal current load per contact ¹⁾ A	Clearance and creepage distance		Test voltage acc. SAE 134412 ²⁾ kVeff	Rated voltage ⁵⁾ kVrms	Termination			View on the termination side	
						Contact to contact in mm	Contact to housing in mm			Solder ³⁾	Crimp ³⁾	Print ⁴⁾	Male contact side	Female contact side
1	P 0	6	0	0.7	4	0.5	0.8	1.000	0.333	●	●	●		
1	P 0	7	0	0.7	4	0.5	0.8	1.000	0.333	●	●	●		
1	P 0	8	9	0.7	4	0.3	0.7	0.600	0.300	●	●	●		

¹⁾ Derating factor see page 73.

²⁾ SAE AS13441:1998 method 3001.1 (kVeff).

³⁾ Tools for assembling see page 61.

⁴⁾ PCB layout see page 42.

⁵⁾ Maximal operating voltage at sea level up to 2.000 m acc. to SAE 13441. More information on page 74.

Termination	Cable cross-section		Contact type	Packaging unit	Part number	Remark
	AWG	mm ²				
Crimp*	22/24	0.38 / 0.25	Stift	500	186.080.103.535.251	Please order contacts separately, not included in delivery
	26/28	0.14 / 0.08	Stift	500	186.080.103.535.151	
	22/24	0.38 / 0.25	Buchse	500	176.082.103.535.251	
	26/28	0.14 / 0.08	Buchse	500	176.082.103.535.151	
Solder						Included in insert
Print (PCB)						Included in insert

* Contacts are delivered on a spool. Larger packaging units are available.

Inserts for Stamped Contacts

Contact type, contact surface and contact diameter

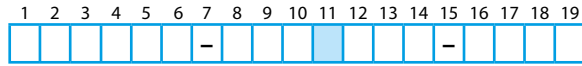

Termination	Contact type	Contact surface	Surface
Solder	Socket	1	Galv. Au
	Pin	2	Galv. Au
Crimp	Socket	3	Galv. Au
	Pin	4	Galv. Au
Print (PCB)	Socket	5	Galv. Au

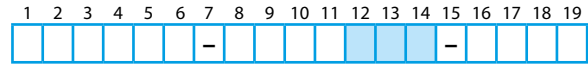

Crimp contacts

Size	Number of contacts	Contact diameter	Contact diameter	Term. cross section	Termination cross section
		mm	F	0	0
1		0.7			
AWG mm ²					
Order contact separately					

Solder contacts

Contact diameter	Termination diameter	Contact diameter	Term. cross section	Termination cross section
mm	mm	F	G	0
0.7	1.0			
AWG mm ²				
22 0.38				

Print (PCB) contacts

Contact diameter	Termination diameter	Contact diameter	Term. cross section
0.7	0.7	F	0

Inserts, Turned Contacts Size 1

Size, number of contacts

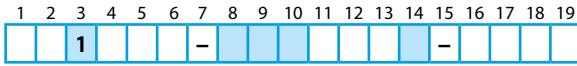

Size	Insulation body	Number of contacts	Alignment in use	Contact diameter mm	Nominal current load per contact ¹⁾ A	Clearance and creepage distance		Test voltage acc. SAE 13441 ²⁾ kVeff	Rated voltage ⁵⁾ kVrms	Termination			View on the termination side	
						Contact to contact in mm	Contact to housing in mm			Solder ³⁾	Crimp ³⁾	Print ⁴⁾	Male contact side	Female contact side
1	P 0 2	2	0	1.3	14	1.3	0.9	1.650	0.550	●	●	●		
1	P 0 3	3	0	1.3	14	1.1	0.8	1.500	0.500	●	●	●		
1	P 0 4	4	0	0.9	10	1.2	0.8	1.500	0.500	●	●	●		
1	P 0 5	5	0	0.9	10	0.8	0.8	1.200	0.400	●	●	●		
1	P 0 6	6	0	0.7	7	0.8	0.8	1.200	0.400	●	●	●		
1	P 0 7	7	0	0.7	7	0.8	0.8	1.200	0.400	●	●	●		
1	P 0 8	8	9	0.7	7	0.6	0.7	1.000	0.333	●	●	●		
1	P 1 0	10	9	0.5	5	0.5	0.8	1.000	0.333	●	●	●		
1	P 1 2	12	0	0.5	5	0.5	0.6	1.000	0.333	●	●	●		
1	P 1 4	14	9	0.5	5	0.5	0.5	0.900	0.300	●	●	●		

¹⁾ Derating factor see page 73.

²⁾ SAE AS13441:1998 method 3001.1 (kVeff).

³⁾ Tools for assembling see page 61.

⁴⁾ PCB layout see page 42.

⁵⁾ Maximal operating voltage at sea level up to 2.000 m acc. to SAE 13441. More information on page 74.

Inserts, Turned Contacts Size 1

Contact type, contact surface and contact diameter

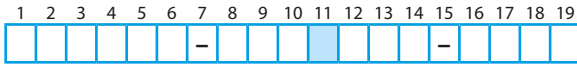

Termination	Contact type	Contact surface	Surface
Solder	Socket	L	Galv. Au
	Pin	M	Galv. Au
Crimp	Socket	N	Galv. Au
	Pin	P	Galv. Au
Print (PCB)	Socket	Q	Galv. Au
	Pin	R	Galv. Au

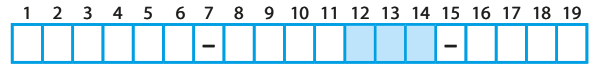

Crimp contacts

Size	Number of contacts	Contact diameter mm	Termination		Termination cross section	
			Contact diameter	Term. cross section	AWG	mm ²
1	6 – 7	0.7	F	C 0	28 – 32	0.09 / 0.04
			F	G 0	22 – 26	0.38 / 0.15
	4 – 5	0.9	J	G 0	22 – 26	0.38 / 0.15
			J	H 0	20 – 24	0.50 / 0.25



Solder contacts

Contact diameter mm	Termination diameter mm	Termination		Termination cross section	
		Contact diameter	Term. cross section	AWG	mm ²
0.5	0.4	C	C 0	28	0.08
0.7	0.6	F	D 0	26	0.15
0.7	0.85	F	G 0	22	0.38
0.9	0.85	J	G 0	22	0.38
1.3	1.1	P	H 0	20	0.50

Print (PCB) contacts

Contact diameter	Termination diameter	Termination		AWG	mm ²
		Contact diameter	Term. cross section		
0.5	0.5	C	0 0		
0.7	0.5	F	0 0		
0.9	0.7	J	0 0		
1.3	0.7	P	0 0		

**PCB Layout for Print Contacts:
Size 1**

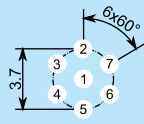
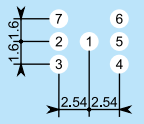
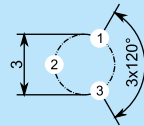
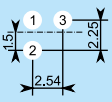
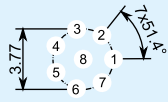
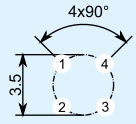
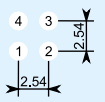
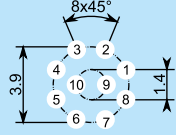
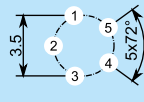
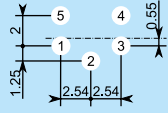
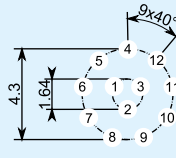
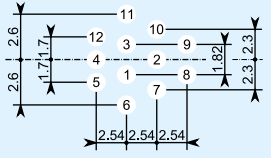
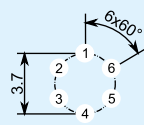
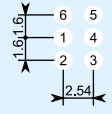
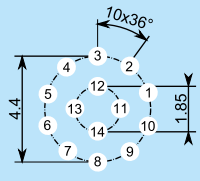





Size 1	Straight	90° right-angled	Size 1	Straight	90° right-angled
2-way	Drill: 0,8 mm 	Drill: 0,9 mm 	7-way	Drill: 0,6 mm 	Drill: 0,7 mm 
3-way	Drill: 0,8 mm 	Drill: 0,9 mm 	8-way	Drill: 0,6 mm 	On request
4-way	Drill: 0,8 mm 	Drill: 0,7 mm 	10-way	Drill: 0,6 mm 	On request
5-way	Drill: 0,8 mm 	Drill: 0,7 mm 	12-way	Drill: 0,6 mm 	Drill: 0,7 mm 
6-way	Drill: 0,6 mm 	Drill: 0,7 mm 	14-way	Drill: 0,6 mm 	On request

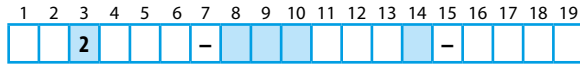

Inserts, Stamped Contacts, Size 2

Size, number of contacts



Size	Insulation body	Number of contacts	Alignment in use	Contact diameter mm	Nominal current load per contact ¹⁾ A	Clearance and creepage distance		Test voltage acc. SAE 13441 ²⁾ kVeff	Rated voltage ⁵⁾ kVrms	Termination			View on the termination side	
						Contact to contact in mm	Kontakt zu Gehäuse in mm			Solder ³⁾	Crimp ³⁾	Print ⁴⁾	Male contact side	Female contact side
2	P	1 2	9	0.7	4	0.6	0.9	1.000	0.333	●	●	●		
2	P	1 4	9	0.7	4	0.5	0.9	1.000	0.333	●	●	●		
2	P	1 6	0	0.7	4	0.5	0.8	1.000	0.333	●	●	●		

¹⁾ Derating factor see page 73.

²⁾ SAE AS13441:1998 method 3001.1 (kVeff).

³⁾ Tools for assembling see page 61.

⁴⁾ PCB layout see page 42.

⁵⁾ Maximal operating voltage at sea level up to 2.000 m acc. to SAE 13441. More information on page 74.

Termination	Cable cross-section		Contact type	Packaging unit	Part number	Remark
	AWG	mm ²				
Crimp*	22 / 24	0.38 / 0.25	Pin	500	186.080.103.535.251	Please order contacts separately, not included in delivery
	26 / 28	0.14 / 0.08	Pin	500	186.080.103.535.151	
	22 / 24	0.38 / 0.25	Socket	500	176.081.103.535.251	
	26 / 28	0.14 / 0.08	Socket	500	176.081.103.535.151	
Solder						Included in insert
Print (PCB)						Included in insert

* Contacts are delivered on a spool. Larger packaging units are available.

Inserts, Stamped Contacts, Size 2

Contact type, contact surface and Inserts

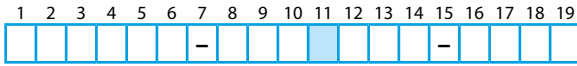

Termination	Contact type	Contact surface	Surface
Solder	Socket	1	Galv. Au
	Pin	2	Galv. Au
Crimp	Socket	3	Galv. Au
	Pin	4	Galv. Au
Print (PCB)	Socket	5	Galv. Au

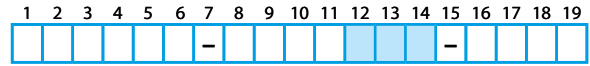

Crimp contacts

Size	Number of contacts	Contact diameter	Contact diameter	Term. cross section	Termination cross section
		mm	F	0	0
2		0.7			
					AWG
					mm ²
					Order contact separately

Solder contacts

Contact diameter	Termination diameter	Contact diameter	Term. cross section	Termination cross section
mm	mm	F	G	0
0.7	1.0			
				AWG
				mm ²
				22
				0.38

Print (PCB) contacts

Contact diameter	Termination diameter	Contact diameter	Term. cross section
mm	mm	F	0
0.7	0.7		

Inserts

Inserts, Turned Contacts, Size 2

Size, number of contacts

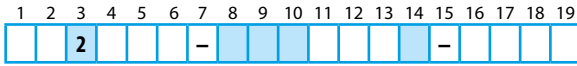

Size	Insulation body	Number of contacts	Alignment in use	Contact diameter mm	Nominal current load per contact ¹⁾ A	Clearance and creepage distance		Test voltage acc. SAE 13441 ²⁾ kVeff	Rated voltage ⁵⁾ kVrms	Termination			View on the termination side	
						Contact to contact in mm	Contact to housing in mm			Solder	Crimp ³⁾	Print ⁴⁾	Male contact side	Female contact side
2	P 0	2	0	1.6	17	2.1	1.6	2.100	0.700	●	●	●		
2	P 0	3	0	1.6	17	1.6	1.6	1.800	0.600	●	●	●		
2	P 0	5	0	1.3	14	1.2	1.1	1.500	0.500	●	●	●		
2	P 0	6	0	0.9	10	1.5	1.3	1.800	0.600	●	●	●		
2	P 0	7	0	0.9	10	1.1	1.2	1.650	0.550	●	●	●		
2	P 0	8	0	0.9	10	1.0	1.3	1.500	0.500	●	●	●		
2	P 0	9	0	0.9 1.3	10 14	0.8 1.8	0.8 3.8	1.350 2.100	0.450 0.700	●	●	●		
2	P 1	10	9	0.9	10	1.0	0.9	1.500	0.500	●	●	●		
2	P 1	11	0	0.9	10	0.8	0.8	1.350	0.450	●	●	●		
2	P 1	12	9	0.7	7	1.0	1.3	1.350	0.450	●	●	●		
2	P 1	16	0	0.7	7	0.8	0.7	1.100	0.366	●	●	●		
2	P 1	19	0	0.7	7	0.7	0.6	1.000	0.333	●	●	●		

¹⁾ Derating factor see page 73.

²⁾ SAE AS13441:1998 method 3001.1 (kVeff).

³⁾ Tools for assembling see page 61.

⁴⁾ PCB layout see page 42.

⁵⁾ Maximal operating voltage at sea level up to 2.000 m acc. to SAE 13441. More information on page 74.

Inserts, Turned Contacts, Size 2

Contact type, contact surface and contact diameter

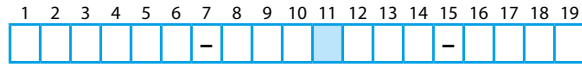

Termination	Contact type	Contact surface	Surface
Solder	Socket	L	Galv. Au
	Pin	M	Galv. Au
Crimp	Socket	N	Galv. Au
	Pin	P	Galv. Au
Print (PCB)	Socket	Q	Galv. Au
	Pin	R	Galv. Au

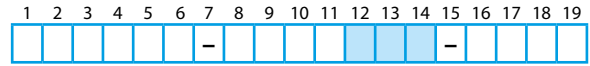

Crimp contacts

Size	Number of contacts	Contact diameter mm	Termination		Termination cross section		
			Contact diameter	Term. cross section	AWG	mm ²	
2	16 – 19	0.7	F	C	O	28 – 32	0.09 / 0.04
			F	G	O	22 – 26	0.38 / 0.15
	5	1.3	P	H	O	20 – 24	0.50 / 0.25
			P	L	O	18 – 20	1.00 / 0.50

Solder contacts

Contact diameter mm	Termination diameter mm	Termination		Termination cross section		
mm	mm	Contact diameter	Term. cross section	AWG	mm ²	
0.7	0.6	F	D	O	26	0.15
0.7	0.85	F	G	O	22	0.38
0.9	0.85	J	G	O	22	0.38
1.3	1.1	P	H	O	20	0.50
1.6	1.4	S	N	O	18	1.00

Print (PCB) contacts

Contact diameter mm	Termination diameter mm	Termination		Termination cross section		
mm	mm	Contact diameter	Term. cross section	AWG	mm ²	
0.7	0.5	F	O	O		
0.9	0.7	J	O	O		
1.3	0.7	P	O	O		
1.6	0.7	S	O	O		

**PCB Layout for Print Contacts:
Size 2**

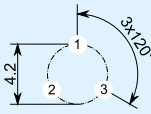
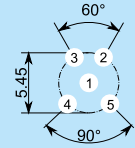
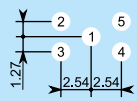
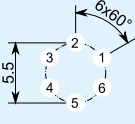
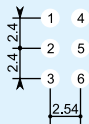
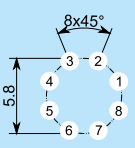
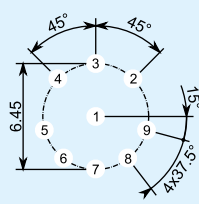
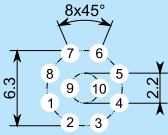
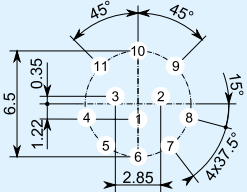
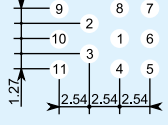
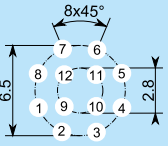
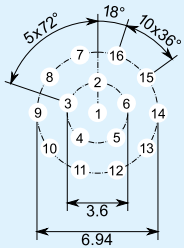
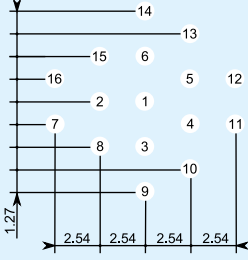
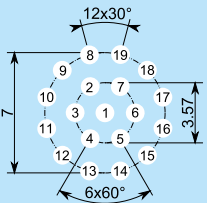
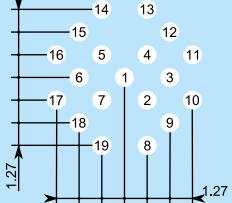
Size 2	Straight	90° right-angled
3-way	Drill: 1.1 mm 	On request
5-way	Drill: 0.8 mm 	Drill: 0.9 mm 
6-way	Drill: 0.8 mm 	Drill: 0.7 mm 
8-way	Drill: 0.8 mm 	On request
9-way	Drill: 0.8 mm 	On request
10-way	Drill: 0.8 mm 	On request
11-way	Drill: 0.8 mm 	Drill: 0.7 mm 
12-way	Drill: 0.6 mm 	On request
16-way	Drill: 0.6 mm 	Drill: 0.7 mm 
19-way	Drill: 0.6 mm 	Drill: 0.7 mm 



Inserts, Stamped Contacts, Size 3

Size, number of contacts

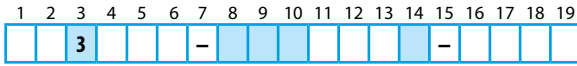

Size	Insulation body	Number of contacts	Alignment in use	Contact diameter mm	Nominal current load per contact ¹⁾ A	Clearance and creepage distance		Test voltage acc. SAE 13441 ²⁾ kV _{eff}	Rated voltage ⁵⁾ kV _{rms}	Termination			View on the termination side	
						Contact to contact in mm	Contact to housing in mm			Solder ³⁾	Crimp ³⁾	Print ⁴⁾	Male contact side	Female contact side
3	P 2 0	0	9	0.7	4	0.6	0.7	1.000	0.333	●	●	●		
3	P 2 2	2	9	0.7	4	0.6	0.7	1.000	0.333	●	●	●		
3	P 2 4	4	0	0.7	4	0.4	1.2	0.900	0.300	●	●	●		
3	P 2 6	6	9	0.7	4	0.4	0.6	0.900	0.300	●				
3	P 2 7	7	0	0.7	4	0.4	0.7	0.900	0.300	●	●	●		

¹⁾ Derating factor see page 73.

²⁾ SAE AS13441:1998 method 3001.1 (kV_{eff}).

³⁾ Tools for assembling see page 61.

⁴⁾ PCB layout see page 42.

⁵⁾ Maximal operating voltage at sea level up to 2.000 m acc. to SAE 13441. More information on page 74.

Termination	Cable cross-section		Contact type	Packaging unit	Part number	Remark
	AWG	mm ²				
Crimp*	22/24	0.38 / 0.25	Pin	500	186.080.103.535.251	Please order contacts separately. Not included in delivery.
	26/28	0.14 / 0.08	Pin	500	186.080.103.535.151	
	22/24	0.38 / 0.25	Socket	500	176.080.103.535.251	
	26/28	0.14 / 0.08	Socket	500	176.080.103.535.151	
Solder						Included in insert
Print (PCB)						Included in insert

* Contacts are delivered on a spool. Larger packaging units are available.

Inserts, Stamped Contacts, Size 3

Contact type, contact surface and contact diameter

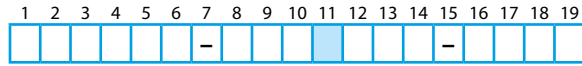

Termination	Contact type	Contact surface	Surface
Solder	Socket	1	Galv. Au
	Pin	2	Galv. Au
Crimp	Socket	3	Galv. Au
	Pin	4	Galv. Au
Print (PCB)	Socket	5	Galv. Au

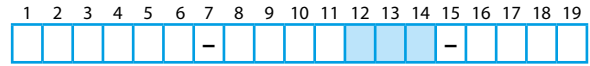

Crimp contacts

Size	Number of contacts	Contact diameter	Contact diameter	Term. cross section	Termination cross section	
		mm	F	0	AWG	mm ²
3		0.7	F	0		Order contact separately

Solder contacts

Contact diameter	Termination diameter	Contact diameter	Term. cross section	Termination cross section	
mm	mm	F	G	AWG	mm ²
0.7	1.0	F	G	22	0.38

Print (PCB) contacts









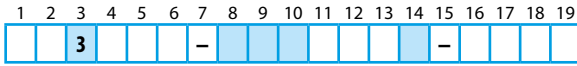





Contact diameter	Termination diameter	Contact diameter	Term. cross section
mm	mm	F	0
0.7	0.7	F	0

Inserts

Inserts, Turned Contacts, Size 3 (Part 1)

Size, number of contacts



Size	Insulation body	Number of contacts	Alignment in use	Contact diameter mm	Nominal current load per contact ¹⁾ A	Clearance and creepage distance		Test voltage acc. SAE 13441 ²⁾ kV _{eff}	Rated voltage ⁵⁾ kV _{rms}	Termination			View on the termination side	
						Contact to contact in mm	Contact to housing in mm			Solder	Crimp ³⁾	Print ⁴⁾	Male contact side	Female contact side
3	P 0 2	2	0	3.0	25	1.7	1.4	1.800	0.600	●				
3	P 0 4	4	9	2.0	22	2.0	1.4	1.650	0.550	●	●			
3	P 0 7	7	9	1.6	17	1.5	1.2	1.800	0.600	●	●	●		
3	P 0 8	8	9	1.3	14	1.4	1.1	1.650	0.550	●	●	●		
3	P 1 0	10	0	1.3	14	1.2	0.9	1.350	0.450	●		●		
3	P 1 2	12	0	1.3	14	1.0	0.9	1.350	0.450	●		●		
3	P 1 4	14	9	0.9	10	1.2	1.0	1.350	0.450	●	●	●		

¹⁾ Derating factor see page 73.

²⁾ SAE AS13441:1998 method 3001.1 (kV_{eff}).

³⁾ Tools for assembling see page 61.

⁴⁾ PCB layout see page 42.

⁵⁾ Maximal operating voltage at sea level up to 2.000 m acc. to SAE 13441. More information on page 74.

Inserts, Turned Contacts, Size 3 (Part 2)

Size, number of contacts

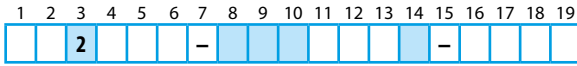

Size	Insulation body	Number of contacts	Alignment in use	Contact diameter mm	Nominal current load per contact ¹⁾ A	Clearance and creepage distance		Test voltage acc. SAE 13441 ²⁾ kV _{eff}	Rated voltage ⁵⁾ kV _{rms}	Termination			View on the termination side	
						Contact to contact in mm	Contact to housing in mm			Solder	Crimp ³⁾	Print ⁴⁾	Male contact side	Female contact side
3	P 1	5	0	0.9	10	0.9	0.8	1.100	0.366	●	●	●		
3	P 1	8	0	0.9	10	0.9	0.8	1.100	0.366	●	●	●		
3	P 2	0	9	0.7	7	0.9	0.8	1.100	0.366	●	●	●		
3	P 2	2	9	0.7	7	0.9	0.7	1.100	0.366	●	●	●		
3	P 2	4	0	0.7	7	0.7	1.2	1.000	0.333	●	●	●		
3	P 2	6	9	0.7	7	0.7	0.6	1.000	0.333	●	●	●		
3	P 2	7	0	0.7	7	0.7	0.7	1.000	0.333	●	●	●		

¹⁾ Derating factor see page 73.

²⁾ SAE AS13441:1998 method 3001.1 (kV_{eff}).

³⁾ Tools for assembling see page 61.

⁴⁾ PCB layout see page 42.

⁵⁾ Maximal operating voltage at sea level up to 2.000 m acc. to SAE 13441. More information on page 74.

Inserts, Turned Contacts, Size 3

Contact type, contact surface and contact diameter

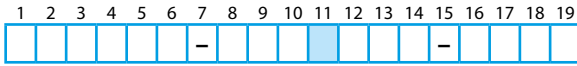

Termination	Contact type	Contact surface	Surface
Solder	Socket	L	Galv. Au
	Pin	M	Galv. Au
Crimp	Socket	N	Galv. Au
	Pin	P	Galv. Au
Print (PCB)	Socket	Q	Galv. Au
	Pin	R	Galv. Au

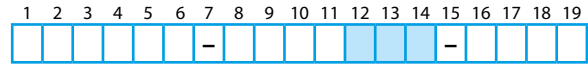

Crimp contacts

Size	Number of contacts	Contact diameter mm	Termination		Termination cross section	
			Contact diameter	Term. cross section	AWG	mm ²
3	24 – 27	0.7	F C O		22 – 26	0.38 / 0.15
	15 – 18	0.9	J G O		22 – 26	0.38 / 0.15
			J H O		22 – 24	0.50 / 0.25

Solder contacts

Contact diameter mm	Termination diameter mm	Termination		Termination cross section	
		Contact diameter	Term. cross section	AWG	mm ²
0.7	0.6	F D O		26	0.15
0.7	0.85	F G O		22	0.38
0.9	0.85	J G O		22	0.38
1.3	1.1	P H O		20	0.50
1.6	1.4	S N O		18	1.00
2.0	1.85	T Q O		14	1.50
2.0	2.4	T S O		12	2.50
3.0	2.7	V T O		10	4.00

Print (PCB) contacts

Contact diameter mm	Termination diameter mm	Termination		Termination cross section	
		Contact diameter	Term. cross section	AWG	mm ²
0.5	0.5	C O O			
0.7	0.5	F O O			
0.9	0.7	J O O			
1.3	0.7	P O O			
1.6	0.7	S O O			
2.0	0.7	T O O			

**PCB Layout for Print Contacts:
Size 3**

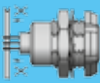
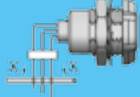
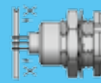
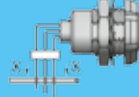
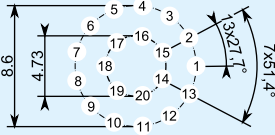
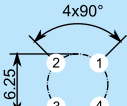
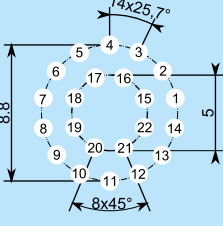
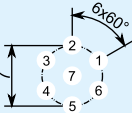
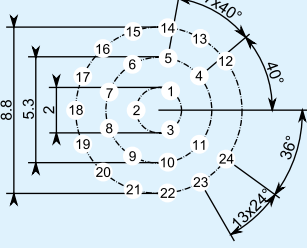
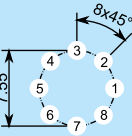
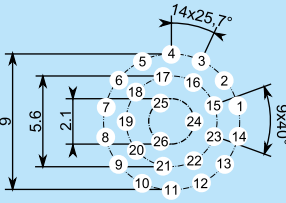
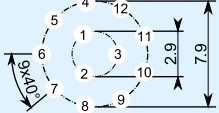
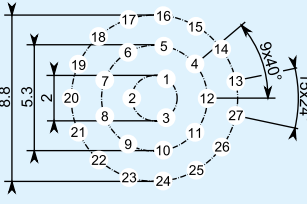
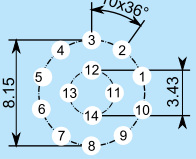
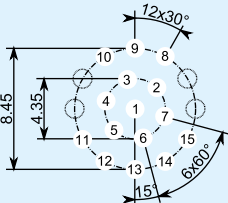
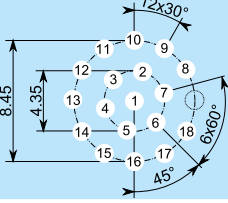
	Straight	90° right-angled		Straight	90° right-angled
Size 3					
2-way	On request	On request	Drill:0.6 mm		On request
4-way	Drill:0.8 mm 	On request	Drill:0.6 mm		On request
7-way	Drill:0.8 mm 	On request	Drill:0.6 mm		On request
8-way	Drill:0.8 mm 	On request	Drill:0.6 mm		On request
12-way	Drill:0.8 mm 	On request	Drill:0.6 mm		On request
14-way	Drill:0.8 mm 	On request			
15-way	Drill:0.8 mm 	On request			
18-way	Drill:0.8 mm 	On request			

Inserts



Accessories



Cable Band Relief made of Silicone

Size	Part number	Dim. L	Cable (outer diameter)	
			min.	max.
1	701.023._.965.025	30	2.5	3.0
	701.023._.965.030		3.0	3.5
	701.023._.965.035		3.5	4.0
	701.023._.965.040		4.0	5.0
	701.023._.965.050		5.0	6.0
	701.023._.965.060		6.0	6.5
	701.023._.965.070		6.5	7.5
2	702.023._.965.025	36	2.5	3.0
	702.023._.965.030		3.0	3.5
	702.023._.965.035		3.5	4.0
	702.023._.965.040		4.0	5.0
	702.023._.965.050		5.0	6.0
	702.023._.965.060		6.0	7.0
	702.023._.965.070		7.0	8.0
	702.023._.965.080		8.0	9.0
3	703.023._.965.040	42	4.0	5.0
	703.023._.965.050		5.0	6.0
	703.023._.965.060		6.0	7.0
	703.023._.965.070		7.0	8.0
	703.023._.965.080		8.0	9.0
	703.023._.965.090		9.0	10.0
	703.023._.965.100		10.0	11.0
	703.023._.965.110		11.0	12.0

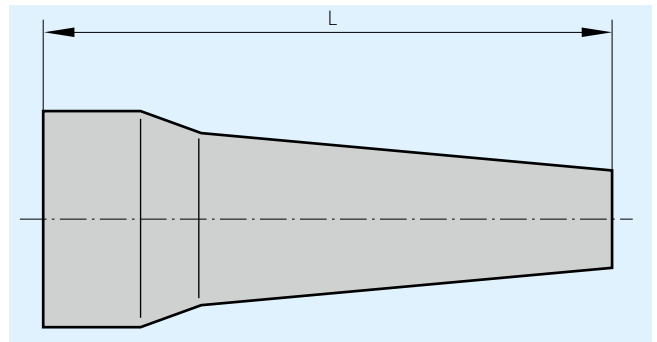
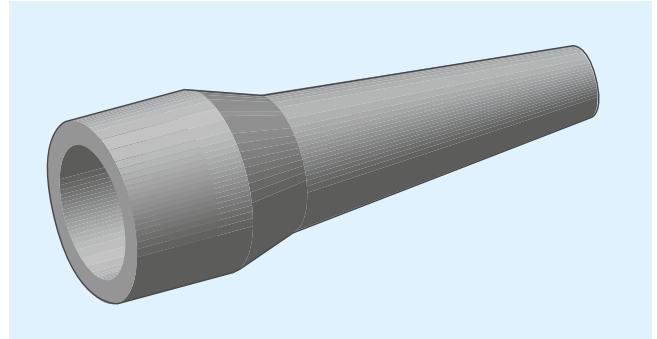

Temperature range

Silicone: -50° C up to +200° C, short-term up to +230° C, autoclavable

Colours

Please indicate colour code.

Colour code	Colour	RAL-no. ¹⁾ (similar)
... 202 ...	Red	3020
... 203 ...	White	9010
... 204 ...	Yellow	1016
... 205 ...	Green	6029
... 206 ...	Blue	5002
... 207 ...	Grey	7005
... 208 ...	Black	9005

¹⁾ Because of different raw materials the colours may slightly differ from RAL numbers.

Cap (attaches with Loop)

In combination with style E ⇒ Degree of protection IP 67
 In combination with styles 1 and 5 ⇒ Degree of protection IP 50

Size 1: IP 50, IP67, with receptacle style E

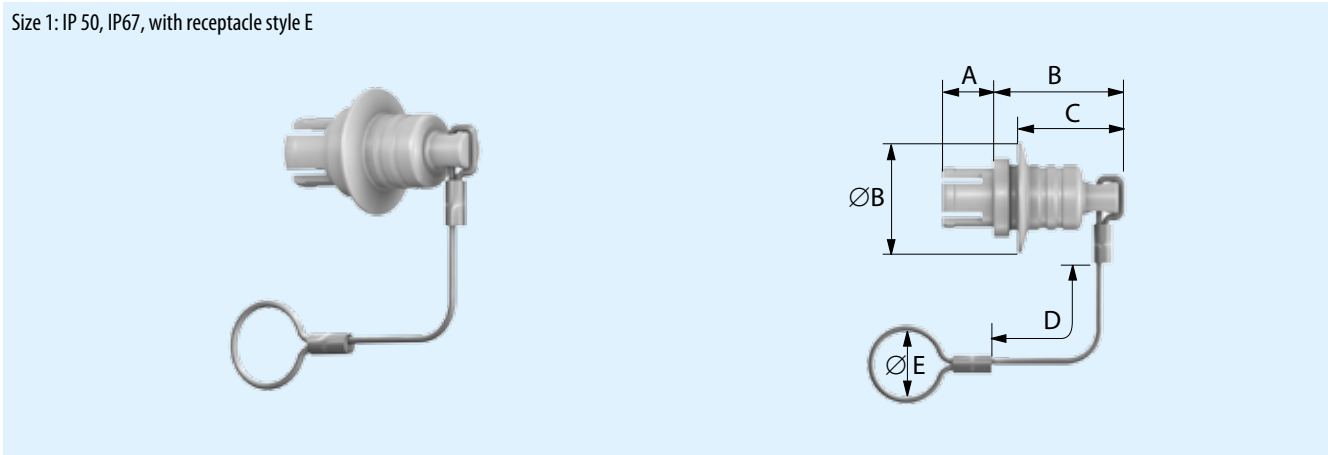

Size	Part number ¹⁾	Dimensions in mm					
		A	B	C	D	ØB	ØE
1	K01 097 006 933 _	7.80	18.80	15.10	75	17	10
2	K02 097 006 933 _	8.10	19.05	15.10	85	20	13
3	K03 097 006 933 _	10.30	19.7	16.00	100	25	16

¹⁾ With _ please, register desired lanyard material
 003 = White and Polyamide lanyard
 008 = Black and Polyamide lanyard
 103 = White and Polyamide lanyard
 108 = Black and Polyamide lanyard

Cap (attaches with Loop)

In combination with style E ⇒ Degree of protection IP 67
 In combination with styles 1 and 5 ⇒ Degree of protection IP 50

Size 1: IP 50, IP67, with receptacle style E

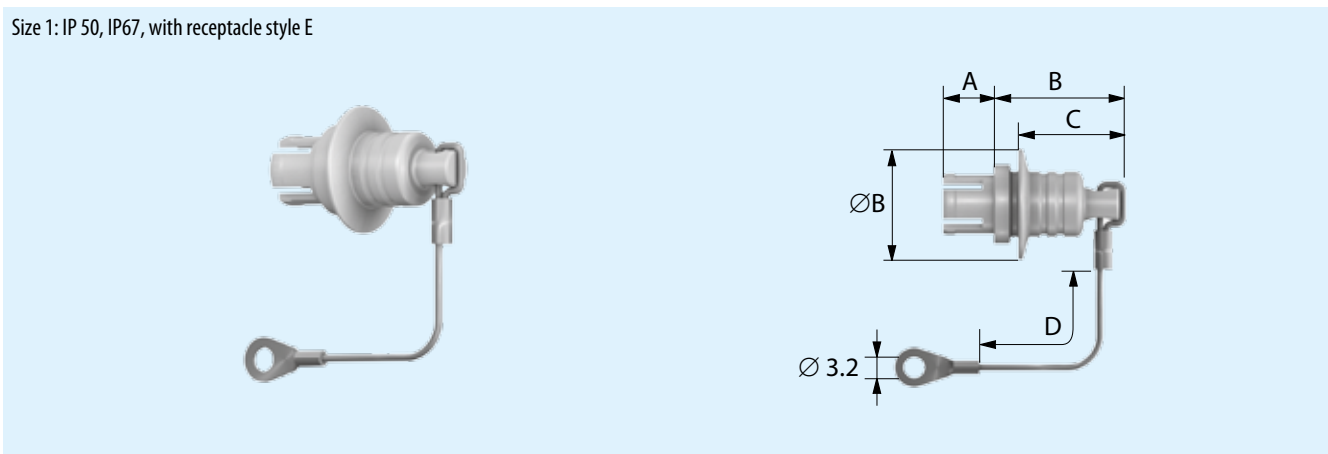

Size	Part number ¹⁾	Dimensions in mm				
		A	B	C	D	ØB
1	K01 097 006 933 _	7.80	18.80	15.10	75	17
2	K02 097 006 933 _	8.10	19.05	15.10	85	20
3	K03 097 006 933 _	10.30	19.7	16.00	100	25

¹⁾ With _ please, register desired lanyard material
 203 = White and Polyamide lanyard
 208 = Black and Polyamide lanyard
 303 = White and Polyamide lanyard
 308 = Black and Polyamide lanyard



Tools



Crimp

The processing of contacts by crimping in order to produce connection lines results in a permanent, corrosion-free and securely contacted connection. It can also be executed by non-experts, and it is time-saving. The cold pressing (crimping) compresses the conductor and contact material at the compression

points so that a gas-tight connection results that corresponds to the conductor material and cannot be pulled apart. There is no need to reinforce the conductor material at the joint such as is the case with soldering. Crimping is possible on the smallest and largest cross-sections.

Crimping Tools for Stamped Contacts (Part I)

The contacts are supplied on a spool for the termination cross-sections AWG 24/22 and AWG 28/26. When assembled, the contact can be slid into the insulator without further tools with a very low force; it then snaps into place in this insulator. Manual crimping tool for single crimp contacts.



The F crimp results in a well-defined, clean pinch.

Manual crimping tool for single crimp contacts.

Here single contacts are manually positioned in the tool and then crimped.

Part number:
080 000 040 000 000

Instructions for use as PDF:
003 069 001 000 000

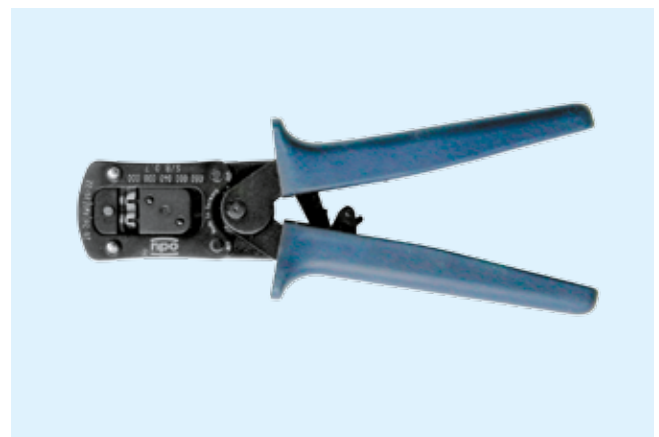

Crimping Tools for Stamped Contacts (Part II)

Manual crimp tool with roll-holder for spool goods

With the manual crimp tool, the contact is fed on a tape and automatically separated during crimping. The feed is done manually.

Part number:

080 000 041 000 000

Instructions for use as PDF:

003 068 001 000 000

For further technical data please request the appropriate data sheet.



Stripper crimper for automatic processing

The automatic crimping tools can process extremely short stripping lengths for the cable sheath, making them ideal for the ODU MINI-SNAP® PC.

Can be ordered from:

Fa. Schäfer Werkzeug und

Sondermaschinen GmbH

www.schaefer-werkzeugbau.com

info@schaefer-werkzeugbau.com



Crimping Tool and Contacting for Turned Contacts

Crimping instructions

The correct crimp position is reached by using the various positioners. You can select the correct crimp diameter by turning the adjusting screw to the selected number.

The tool has a blocking system, which prevents them from opening before the pressing has been completed.

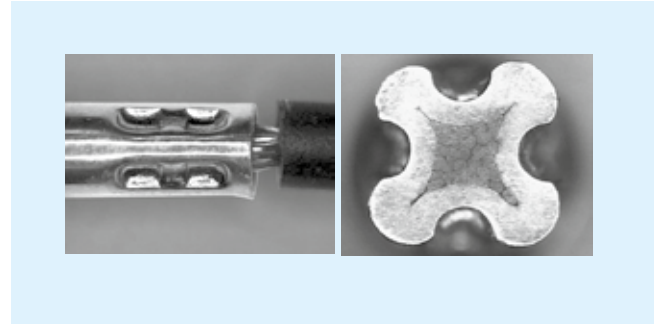

Part number crimping tools	080.000.051.000.000
Part number positioner	see table
Instructions for use as PDF	003 089 001 000 000

Crimp Accessories and Processing Information for Turned Contacts

Size	Number of contacts	Contact diameter	Cross section		Adjustment	Positioner	Position		Removal tool
			AWG	mm ²			Pin	Socket	
1	8	0.7	28 – 32	0.09 / 0.04	0.57	080.000.051.108.000	1	4	087.7CC.070.001.000
	8	0.7	22 – 26	0.38 / 0.15	0.57	080.000.051.108.000	1	4	087.7CC.070.001.000
	6 – 7	0.7	28 – 32	0.09 / 0.04	0.57	080.000.051.108.000	3	4	087.7CC.070.001.000
	6 – 7	0.7	22 – 26	0.38 / 0.15	0.67	080.000.051.108.000	3	4	087.7CC.070.001.000
	4 – 5	0.9			0.67	080.000.051.108.000	5	6	087.7CC.090.001.000
	4 – 5	0.9	20 – 24	0.50 / 0.25	0.67	080.000.051.108.000	5	6	087.7CC.090.001.000
2	16 – 19	0.7	28 – 32	0.09 / 0.04	0.57	080.000.051.110.000	1	2	087.7CC.070.001.000
	16 – 19	0.7	22 – 26	0.38 / 0.15	0.67	080.000.051.110.000	1	2	087.7CC.070.001.000
	12	0.7	28 – 32	0.09 / 0.04	0.57	080.000.051.110.000	1	2	087.7CC.070.001.000
	12	0.7	22 – 26	0.38 / 0.15	0.67	080.000.051.110.000	1	2	087.7CC.070.001.000
	10	0.9			0.67	080.000.051.108.000	5	–	087.7CC.090.001.000
	10	0.9	20 – 24	0.50 / 0.25	0.67	080.000.051.108.000	5	–	087.7CC.090.001.000
	10	0.9	22 – 26	0.38 / 0.15	0.67	080.000.051.110.000	–	8	087.7CC.090.001.000
	10	0.9	20 – 24	0.50 / 0.25	0.67	080.000.051.110.000	–	8	087.7CC.090.001.000
	5	1.3			0.67	080.000.051.110.000	3	4	087.7CC.130.001.000
	5	1.3	18 – 20	1.00 / 0.50	1.12	080.000.051.110.000	3	4	087.7CC.130.001.000
3	24 – 27	0.7	22 – 26	0.38 / 0.15	0.67	080.000.051.110.000	1	6	087.7CC.070.001.000
	15 – 18	0.9			0.67	080.000.051.110.000	7	8	087.7CC.090.001.000
	15 – 18	0.9	20 – 24	0.50 / 0.25	0.67	080.000.051.110.000	7	8	087.7CC.090.001.000

Spanner Wrench

Part number	SW	t	B	L	b
598.700.001.003.000	12	2.5	24.5	115	10.0
598.700.001.004.000	13	2.5	30.5	98	16.5
598.700.001.005.000	14	2.5	30.5	98	16.5
598.700.001.007.000	16	3.0	35.5	145	15.0
598.700.001.008.000	17	3.0	35.5	145	15.0
598.700.001.013.000	19	3.0	42.0	172	16.0
598.700.001.014.000	24	3.0	54.0	119	23.5

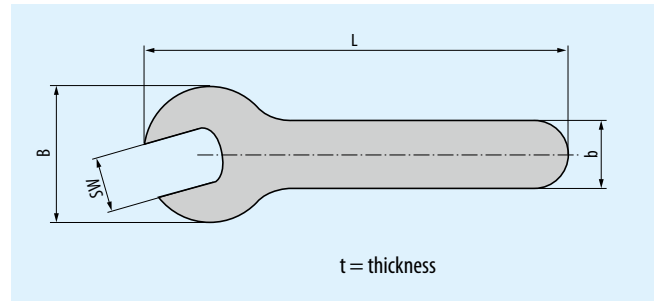

Assembly Instruction

Assembly instructions are available for **download on our website:**
www.odu.de/downloadcenter.html

The following instruction sheets for assembly are available for download:

MINI-SNAP PC
 (IP 50 + IP 67 identical)

Technical Information

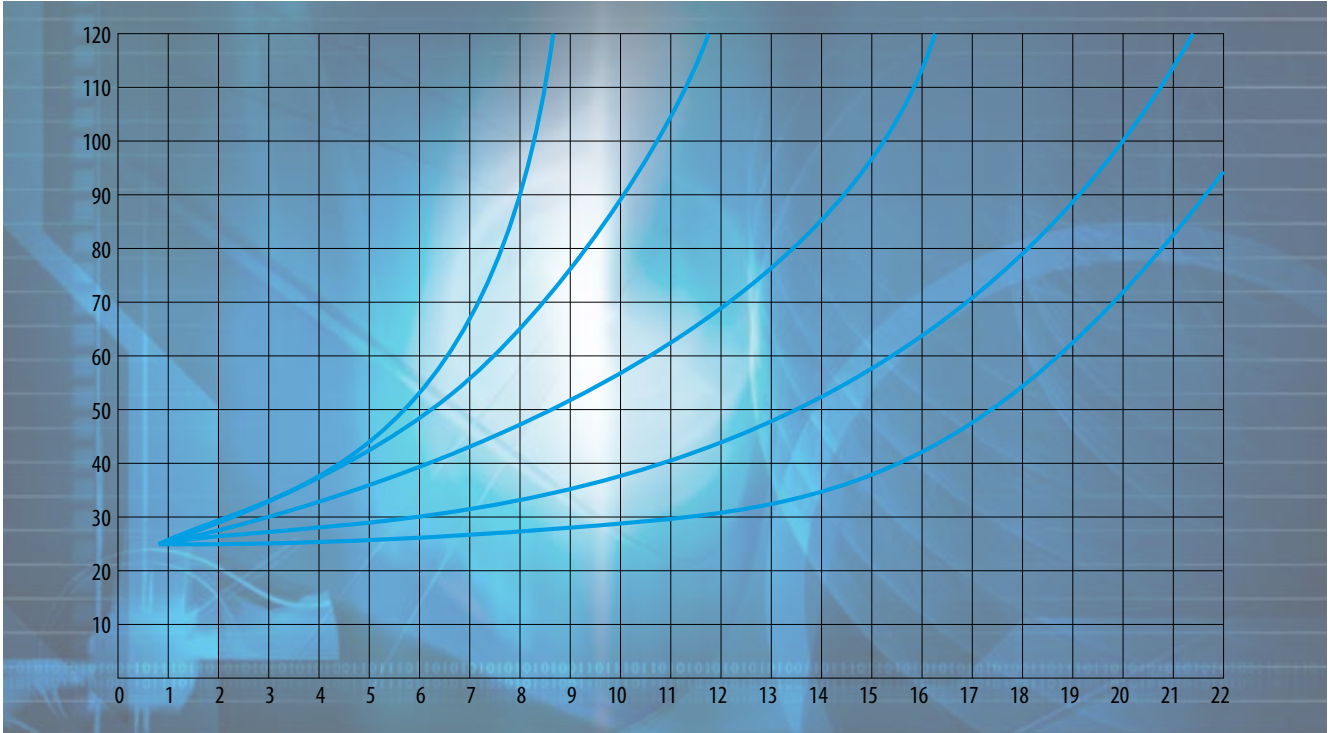

International Protection (IP) Classes DIN EN 60 529 (respectively IEC 529/VDE 0470 T1)

Code letters (International Protection)		First code number (Protection against solid foreign bodies)		Second code number (Protection against water)		
IP		6		5		
Code number	Extent of protection		Code number	Extent of protection		
0	No protection		No protection against contact, no protection against solid foreign bodies	0	No protection against water	No protection against water
1	Protection against large foreign bodies		Protection against large-surface contact with the back of the hand, protection against foreign bodies $\varnothing \geq 50$ mm	1	Protection against dripping water	Protection against vertically falling water drops
2	Protection against medium-sized foreign bodies		Protection against contact with the fingers, protection against foreign bodies $\varnothing \geq 12$ mm	2	Protection against dripping water when tilted	Protection against falling water drops when tilted (any angle up to 15° from the vertical)
3	Protection against small foreign bodies		Protection against contact with tools, wires, or the like with $\varnothing \geq 2,5$ mm, protection against foreign bodies $\varnothing \geq 2,5$ mm	3	Protected against spraying water	Protection against water spraying at any angle up to 60° from the vertical
4	Protection against granular foreign bodies		The same as 3, except ≥ 1 mm	4	Protection against splashing water	Protection against splashing water from all directions
5	Protection against dust deposits		Protection against contact, protection against harmful dust deposit in the interior	5	Protection against water jet	Protection against water jet (nozzle) from any angle
6	Protection against dust ingress		Protection against foreign bodies ≥ 1 mm, protection against dust ingress	6	Protection against powerful water jet	Protection against powerful water jet from any angle
				7	Protection against immersion	Protection against water ingress during temporary immersion
				8	Protection against continuous immersion	Protection against pressurized water during continuous immersion
				9k¹⁾	Protection against high pressure	Protection against water from high-pressure/ steam jet cleaners

¹⁾ IP ×9k is not included in EN 60529 or IEC 60529, but is included in DIN 40 050-9.

Housing Material and Surface Finish

Component	Material	Surface
Housing	PEI	
Housing: shielded	PEI	Partial Cu Ni
Back nut	PEI	
Sleeve	PEI	
Cable collet	PA/PSU	
Nut / receptacle plastic	PEI	
Nut / receptacle shielded	Cu alloy	Ni
Stamped contacts	Cu alloy	Ni Au (Contact area) Sn (Connection area)
Turned contact	Cu alloy	Ni Au

Insulation Body Material (RoHS 2011/65/EC approved)

	Standard	Unit	PEEK
Dielectric strength	DIN 53481 ASTM D-149	kV / mm	19
Operating temperature	–	°C	– 50 / +250
Fire class	UL – 94	–	V – 0
Comparative figure of the creepage path formation CIT.	IEC 60 112	V	175

Termination Technologies

Contact blocks (insulation bodies with contacts) are interchangeable between receptacle and plug. The same applies to the insulator with the socket contacts. As a rule the socket contact blocks are mounted in the part under power (because touch-proof).

With respect to the termination technologies, the type of mounting used for the contacts in the insulator is important. ODU offers the following contact termination styles:

- Solder
- Crimp
- Print (PCB)

Termination styles for turned contacts

Solder termination

The contacts come mounted by the factory. The insulation body and the pre-assembled contacts are called a contact block.

Crimp termination

A single contact is crimped to a single conductor. Subsequently, the crimped contact is pushed into the insulation body. Crimp contacts and insulation bodies are shipped separately.

Crimping creates a reliable, corrosion-free and durable connection between the contact and the conductor. Crimping causes the crimp barrel of the contact and the conductor material to cold flow. It creates a gas-tight connection between contact and conductor.

The ODU MINI-SNAP generally requires the industry standard 8-point crimping tool.

Printed circuit board (PCB) termination

PCB pins are used only for receptacles which are mounted directly to the PCB (Further information upon request).

Solder termination

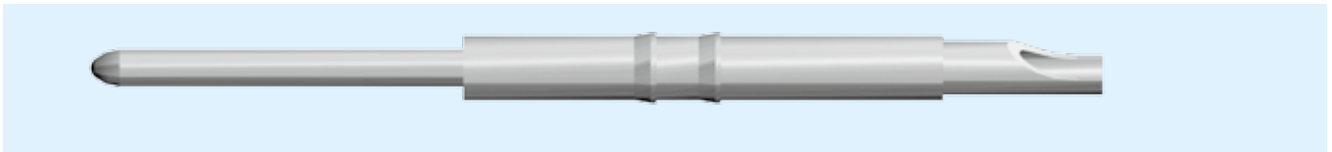

Crimp termination (Crimp-clip-contact for PEEK Insulator)

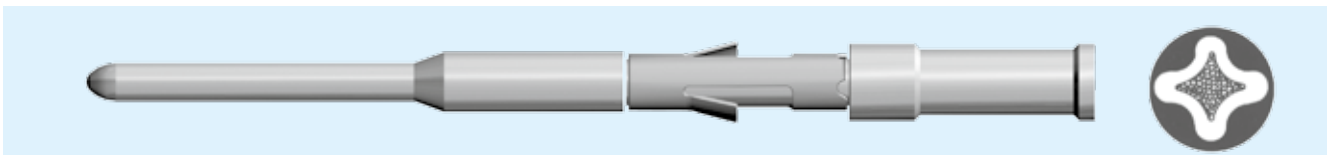

Printed circuit board (PCB) termination

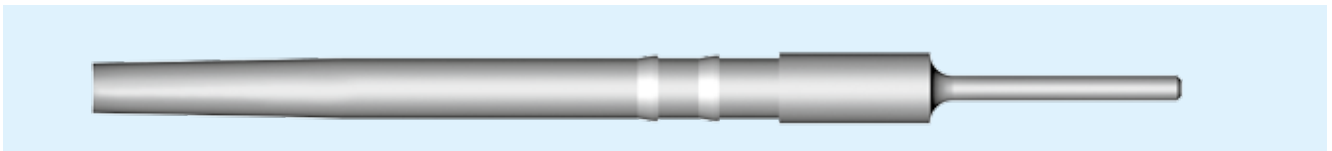

Conversions AWL – Cross Section (AWG = American Wire Gauge)

The AWG system describes the cross section of a wire using a gauge number for every 26 % increase in conductor cross section. With larger wire diameters, the AWG gauge numbers decrease; as the wire sizes increase, the AWG gauge numbers decrease. **This is only valid for solid conductors.**

Most wires are made with stranded conductors . Compared to solid conductors stranded wires offer higher durability, higher flexibility and better performance under bending and vibration.

Stranded wires are made from wires with smaller gauge sizes (higher AWG gauge number). The AWG gauge number of the stranded wire is equal to that of a solid conductor of the same size wire. The cross section of the stranded conductor is the sum of cross sections of the single conductors.

For example, an AWG-20 stranded wire of 7 AWG-28 conductors has a cross section of 0.563 mm²; an AWG-20 stranded wire with 19 AWG-32 conductors has a cross section of 0.616 mm².

Conversion table: AWG-mm²

AWG	Circular wire				
	Diameter		Cross-section mm ²	Weight kg/km	Max. resistance Ω/km
	Inch	mm			
10 (1)	0.1020	2.5900	5.2700	47.000	3.45
10 (37/26)	1.1090	2.7500	4.5300	43.600	4.13
12 (1)	0.0808	2.0500	3.3100	29.500	5.45
12 (19/25)	0.0895	2.2500	3.0800	28.600	6.14
12 (37/28)	0.0858	2.1800	2.9700	26.300	6.36
14 (1)	0.0641	1.6300	2.0800	18.500	8.79
14 (19/27)	0.0670	1.7000	1.9400	18.000	9.94
14 (37/30)	0.0673	1.7100	1.8700	17.400	10.50
16 (1)	0.0508	1.2900	1.3100	11.600	13.94
16 (19/29)	0.0551	1.4000	1.2300	11.000	15.70
18 (1)	0.0403	1.0200	0.8200	7.320	22.18
18 (19/30)	0.0480	1.2200	0.9600	8.840	20.40
20 (1)	0.0320	0.8130	0.5200	4.610	35.10
20 (7/28)	0.0366	0.9300	0.5600	5.150	34.10
20 (19/32)	0.0384	0.9800	0.6200	5.450	32.00
22 (1)	0.0252	0.6400	0.3240	2.890	57.70
22 (7/30)	0.0288	0.7310	0.3540	3.240	54.80
22 (19/34)	0.0307	0.7800	0.3820	3.410	51.80
24 (1)	0.0197	0.5000	0.1960	1.830	91.20
24 (7/32)	0.0230	0.5850	0.2270	2.080	86.00
24 (19/36)	0.0252	0.6400	0.2400	2.160	83.30
26 (1)	0.1570	0.4000	0.1220	1.140	147.00
26 (7/34)	0.0189	0.4800	0.1400	1.290	140.00
26 (19/38)	0.0192	0.4870	0.1500	1.400	131.00
28 (1)	0.0126	0.3200	0.0800	0.716	231.00
28 (7/36)	0.0150	0.3810	0.0890	0.813	224.00
28 (19/40)	0.0151	0.3850	0.0950	0.931	207.00
30 (1)	0.0098	0.2500	0.0506	0.451	374.00
30 (7/38)	0.0115	0.2930	0.0550	0.519	354.00
30 (19/42)	0.0123	0.3120	0.0720	0.622	310.00
32 (1)	0.0080	0.2030	0.0320	0.289	561.00
32 (7/40)	0.0094	0.2400	0.0350	0.340	597.10
32 (19/44)	0.0100	0.2540	0.0440	0.356	492.00
34 (1)	0.0063	0.1600	0.0201	0.179	951.00
34 (7/42)	0.0083	0.2110	0.0266	0.113	1.491.00
36 (1)	0.0050	0.1270	0.0127	0.072	1.519.00
36 (7/44)	0.0064	0.1630	0.0161	0.130	1.322.00
38 (1)	0.0040	0.1000	0.0078	0.072	2.402.00
40 (1)	0.0031	0.0800	0.0050	0.043	3.878.60
42 (1)	0.0028	0.0700	0.0038	0.028	5.964.00
44 (1)	0.0021	0.0540	0.0023	0.018	8.660.00

Source: Gore & Associates, Pleinfeld

Current Load of Stamped Contacts

Nominal single contact current load for pin / slotted socket (nominal diameter 0.7)

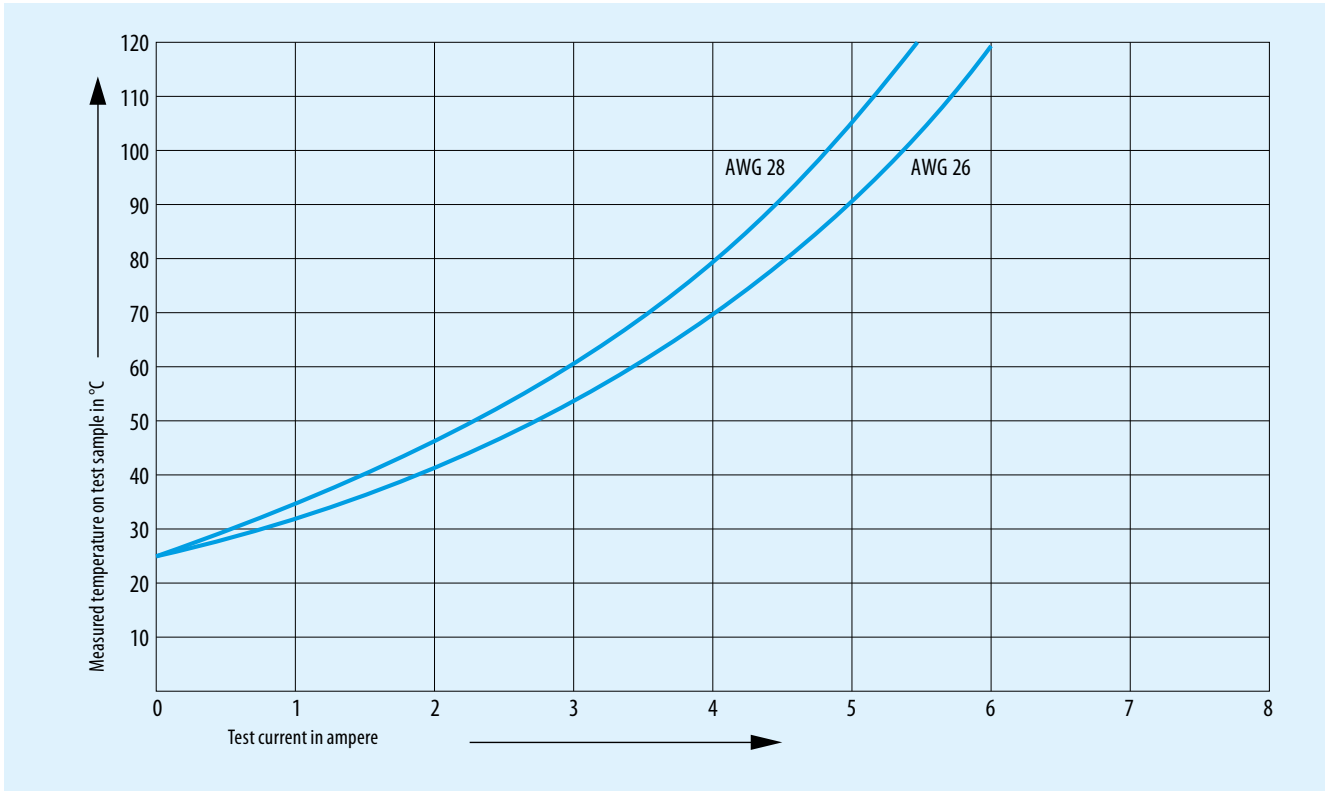

Mating force: ..0.35.. N
 Demating force: ..0.33.. N

Conclusion:
 As can be seen in the diagram, for example, with a current load of 4 A, the connection.

- heats to a temperature of approx. 70° C with termination AWG 26
- heats to a temperature of approx. 79° C with connection AWG 28

Derating factor

Number of loaded wires	Derating factor
5	0.75
7	0.65
10	0.55
14	0.50
19	0.45
24	0.40

Current Load of Turned Contacts

Nominal single contact current load for pin / slotted socket (nominal diameter 0.5 mm – 1.6 mm)

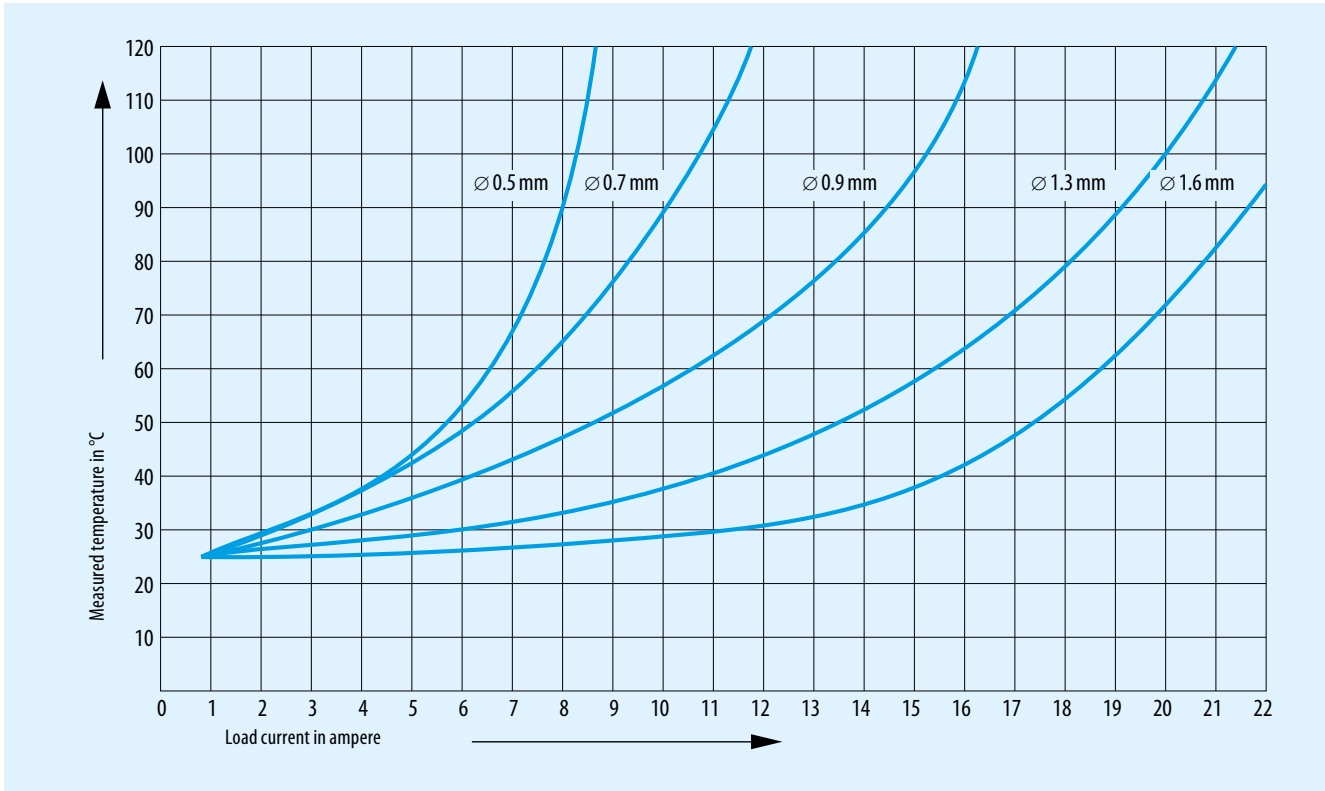

Maximum operating temperature for standard contacts:
+120° C

Test contact was terminated to largest possible conductor.

Connectors or cables with more than one contact or conductor generate a higher heat than a single contact. Therefore, a derating factor must be applied. For connectors the derating factor is applied according to DIN 57 298 Part 4 / VDE 0298 Part 2. The derating factor is used starting with 5 loaded wires (DIN 41 640 T3).

Derating factor

Number of loaded wires	Derating factor
5	0.75
7	0.65
10	0.55
14	0.50
19	0.45
24	0.40

Operating Voltage acc. to SAE AS 13441-Method 3001.1

The values acc. to SAE AS 13441-method 3001.1 comply with MIL-Std. 1344 – method 3001. The chart values results are acc. to IEC 60512-2; Test 4. The inserts have been tested in mated condition and the test voltage was applied to the pin insert.

75 % of the measured break-down voltage is the basic for the further calculation. 1/3 of this value is the corresponding operating voltage.

All tests were performed at standard environment conditions (room temperature) and can be applied up to an altitude of 2,000 m. For any deviations one has to consider the reduction factor acc. to the relevant standards.

Test voltage: $\text{Break-down voltage} \times 0.75$
Operating voltage: $\text{Break-down voltage} \times 0.75 \times 0.33$

Caution

Electrical appliances: for various applications the safety requirements regarding the operating voltage is even more severe! The relevant data in such cases for the operating voltage are the creepage and clearance distances. For advice on how to choose the proper connector please consult us and indicate the safety standard which your product has to meet.

Electromagnetic Compatibility (EMC)

When discussing electromagnetic compatibility (EMC) one should not only consider the device or the circuit, but also include the network and the entire data communication link. This involves all connecting elements such as conductors and connectors. Electromagnetic interference from the outside into the connector can lead to system malfunctioning. The best way to prevent this is by providing a high-quality shield between the cable and the connector. In order to provide reliable EMC data to our customers we engaged the services of a certified test laboratory to investigate the EMC characteristics of the ODU MINI-SNAP. They tested for us size 00, 0, 1, 2 and 3 MINI-SNAP connectors.

Measurements were conducted using the inductive wire or parallel wire method in accordance with test procedure VG 55214-6-2. In this set-up, the mated connector is connected on one end to a network analyzer and terminated on the other end with a suitable impedance. The inductive wire is then mounted in close proximity along the mated connector pair. The induction wire is a ribbon cable which permits to vary the level of induction by using more or less of the ribbon conductors.

Next, a signal with a frequency range of 10 kHz to 3 GHz is connected to the ribbon cable. The network analyzer is used to measure the amount of signal induced into the

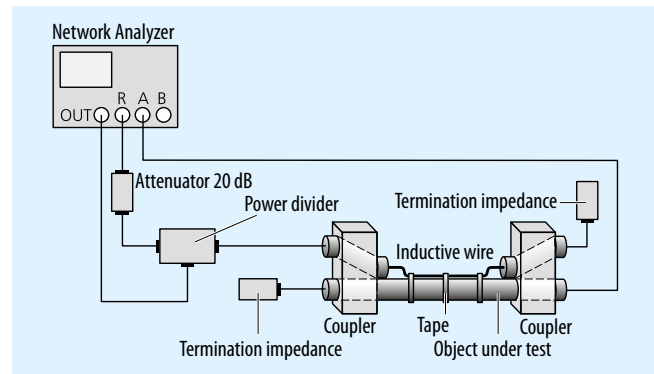

connector circuit. The result is shown as the shielding attenuation AT in dB. It is essential that all leads to the connector are shielded so that no signal can be induced into the circuit at any other place except the connector.

The various attenuation values are plotted on a logarithmic scale as attenuation in dB vs. frequency.

An attenuation of better than - 55 dB is generally required for reliable connector and system operation. It can be shown that our connectors will meet this requirement in all applications.

The following diagram is valid for all series and standard sizes.

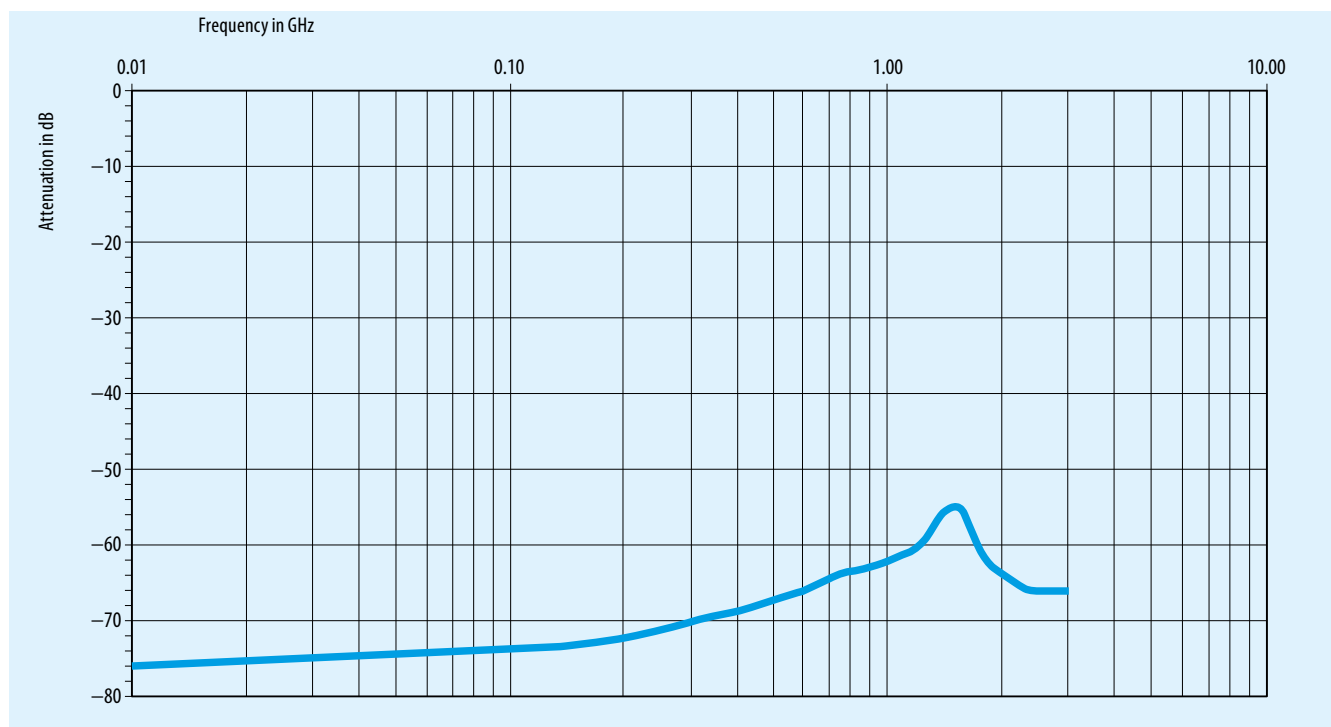

Autoclaving of ODU MINI-SNAP® PC Connectors

If required ODU can deliver MINI-SNAP connectors for the following sterilization process: Steam-sterilization with pre-vacuum or gravitation process.

Connectors were tested with autoclave equipment with reference to DIN EN 13060 at 134° C and 200 cycles. For other sterilization-processes please contact our technical support team.

Sterilization curve:

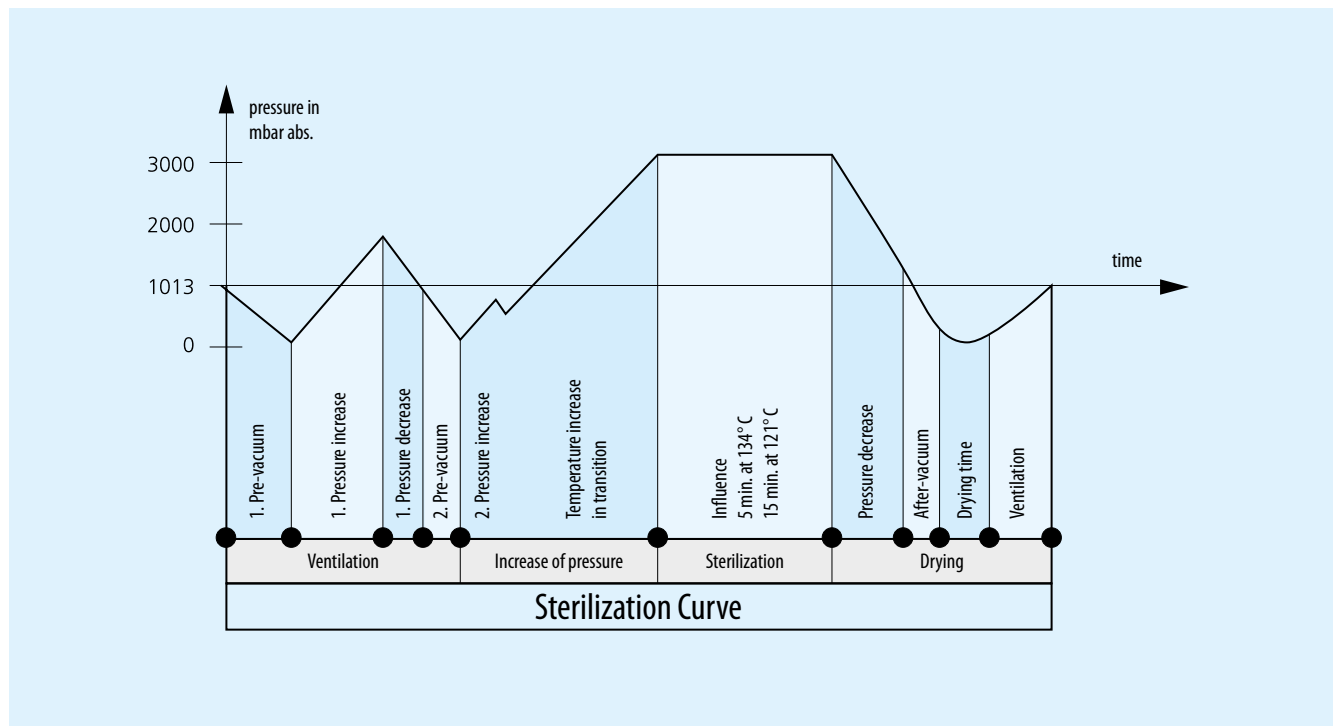

Please contact our technical team for additional sterilization methods.

Test Standard

In the scope of quality approval the sizes 0 and 3 have been submitted to environmental and mechanical tests acc. to MIL. All tests have been passed.

Test carried out

Definition	Standard
High temperature	MIL-STD 810 F / PV 501
Low temperature	MIL-STD 810 F / PV 502
Temperature shock	MIL-STD 810 F / PV 503
Humidity	MIL-STD 810 F / PV 507
Salt fog	MIL-STD 810 F / PV 509 and MIL-STD 1344 A / Method 1001.1
Shock	MIL-STD 810 F / PV 516
Vibration	MIL-STD 1344 A / Method 2005.1 / IV
Water tightness IP 68	IEC 60529

Technical Information / Definitions / Terms

Air gap

Shortest distance between two conductive elements through the air.

Autoclavability

See page 76.

AWG

See page 71.

Chemical resistance

Adhesives, cleaners, or other chemicals are used on our products in a large number of further processing steps. Inappropriate chemicals may chemically damage the material structure and result in material breakage of the plastic bodies. Please follow our processing recommendations and technical instructions in this catalog.

Connector

A component which terminates conductors for the purpose of providing connection and disconnection to a suitable mating component. Depending on the fastening to a cabinet, panel, rack etc. or a cable, they are classification.

Creepage distance

The distance measured across the surface of a dielectric between two contacts or a contact and a metal part. The longer the distance, the lesser the risk of damage or tracking. Minimum creepage distances are specified according to the operating voltage and the applicable isolation group.

Crimping area

The part of a crimp barrel at which the crimp connection is achieved by pressure deformation or by reshaping the barrel around the conductor.

Crimp barrel

A hollow part of a contact which accepts one or more conductors and which may be crimped through the application of a crimping tool.

Crimp connection

The permanent attachment of a contact to a conductor by pressure deformation or by reshaping the crimp barrel around the conductor so that a good electrical and mechanical connection is established. (See page 70).

Delivery

Delivery of the connectors usually as components (that means not assembled). Exception: Solder contacts are factory-installed in the insulation body.

Fixed connector

A connector for attachment to a rigid surface (panel).

Free connector

A connector for attachment to the free end of a wire or cable. Also called free hanging connector or in-line receptacle.

Insertion or withdrawal force

The force required to fully mate or unmate a set of connectors without the effect of coupling, locking or similar devices. The insertion force is usually greater than the withdrawal force. Also called mating and unmating force.

Insulation body

Non-conductive part of a connector, to electrically and mechanically separate live parts and to protect against accidental touch.

Insulation group

Classification of connectors according to the operating and working conditions (insulation groups according to DIN VDE 0110).

Keying

System of projections and grooves on mating connectors which prevent otherwise identical connectors from being mated. This is useful when several connectors of the same style are used in the same application.

Lower limit temperature

The lowest permissible temperature which a connector or a plug-in device is allowed to be operated. At ODU MINI-SNAP -40° C.

Materials

The contacts are made of Cu-alloy and gold-plated. The standard housings are made of Cu-alloy with a matt-chromate surface finish. All other materials and surfaces on special request (see page 69).

Mating cycles

Mechanical operation of connectors and plug-in devices by insertion and withdrawal. One mating cycle comprises one insertion and one withdrawal operation. Nominal single contact current load Current load, which can load every single contact (see page 73).

Nominal voltage

Nominal voltage characterizes a component.

Operating temperature of the ODU MINI-SNAP

Range between upper and lower temperature limits. – 40° C to +120° C (see page 7).

Print (PCB) connection

See page 70.

Printed circuit board

Boards, typically made of epoxy-filled glass fiber fabric, with conductive pattern on one or both sides, or in case of multilayer boards, also imbedded inside the board. They feature metalized holes for soldering wire-mounted components or for the insertion of resilient or rigid press-in pins or instead, pads for attaching components using surface mount technology (SMT).

Reference current

The current at which a connector can be operated permanently simultaneously through all contacts without reaching maximum temperature.

Reference voltage

Normal voltage (VDE 0110) for a connector.

Solder termination

See page 70 termination styles.

Termination cross-section

The indicated cross-sections correspond to a flexible conductor design in accordance with EN 60228:2005 class 5 or to a flexible conductor design (7/19 strands) in accordance with AWG (ASTM B258-02).

Termination techniques

Methods for connecting a wire to an electro-mechanical component, e. g. solderless connection according to IEC 60352: respectively such as crimp, press-in etc. or solder connections.

Test voltage

The voltage the connectors are tested, and are being referred on definite characteristics.

Upper limit temperature

Highest permissible temperature at which a connector or a plug-in device is allowed to operate. This temperature includes the self-heating and the ambient temperature. At ODU MINI-SNAP +120° C (see page 73).

Watertightness (DIN EN 60529)

See page 68.

Wire

Wires may be provided with an insulation cover, an electrical shielding. Cables or conductors may consist of one or more wires.

Connectors shown in this catalogue are designed to operate at high voltages and high frequencies. Care must be taken to assure that no person can come in contact with live conductors during installation or operation of the connectors.

ODU reserves the right to change design and performance of any product to meet changing technical developments without prior notice. ODU reserves the right to discontinue any part in this catalogue without prior notice and without obligation to continue production after the change.



Company Information



Quality Management

ODU has had a powerful quality management system in place for years. ODU has been successfully certified to ISO 9001 since 1994. In addition, the automotive sector of the company is certified to ISO TS 16949. The certification process was carried out by the internationally active BVQI (Bureau Veritas Quality International company).

ODU is also certified according to the medical standard ISO 13485: 2003 + AC: 2007.

In addition, ODU is certificated to DIN EN ISO 14001:2009 as well as to different certifications: VDE, UL, UL wiring harness, SCA, VG and ML.



Your Partner in Many Application Areas

ODU stands for quality, flexibility and reliability. This is why customers working in many application areas rely on ODU products in markets such as the following:

- Medical
- Industrial
- Measurement and testing
- Military and security
- Energy
- Automotive



MEDICAL



INDUSTRIAL



MEASURING AND TESTING



MILITARY AND SECURITY



ENERGY



AUTOMOTIVE

Overview – All Push-Pull Connector Series from ODU

	Push pull locking	Coding	Sizes	No. of mechanical coding	Diameter plug (mm)	Max cable Ø (mm)	Max no. of contacts	Solder	Crimp	print	IO Protection Class A ¹⁾	IP Protection Class B ²⁾
ODU MINI-SNAP L		Pin and groove	00	4	6.5	3.5	04				IP 50	to IP 68
			0	6	9.5	5.6	10					
			1	7	12.0	7.7	16	●	●	●		
			2	8	15.0	9.9	26					
			3	7	18.0	11.9	30					
ODU MINI-SNAP K		Pin and groove	0	4	11.0	5.0	10				IP 68	to IP 68
			1		13.0	7.0	16					
			2	1	16.0	9.0	26	●	●	●		
			3	1	19.0	10.5	30					
			4	1	25.0	14.0	40					
ODU MINI-SNAP B		Pin and groove	0	6	9.4	5.0	10				IP 68	bis IP 68
			1	8	12.0	7.0	16	●	●	●		
			2	8	15.0	9.0	26					
			3	10	18.0	10.5	30					
ODU MINI-SNAP S		Insulation body	0	1	9.4	5.0	04				to IP 68	to IP 68
			1		12.0	7.0	05	●	●			
			2		15.0	9.0	10					
ODU MINI-SNAP F		Half shell	0	2	9.4	5.0	09				to IP 68	to IP 68
			1	2	12.0	7.5	12					
			1.5	2	13.0	7.5	19	●	●	●		
			2	2	15.0	9.5	19					
			3	3	18.0	11.5	27					
ODU AMC		Pin and groove	0	4	14.0	5.5	10				to IP 69K	IP 68
			1		15.9	6.5	16					
			1.5		16.5	8.0	19	●		●		
			2		19.6	10.0	26					
			3		23.9	11.5	37					
			4		33.0	17.5	55					
ODU MINI-SNAP PC		Half shell	1	3	12.5	6.0	14				to IP 67	IP 50
			2		15.7	9.0	19	●	●	●		
			3		18.7	10.5	27					
ODU MEDI-SNAP		Pin and groove	1	6	13.7	6.5	14				to IP 64	IP 50
			2	1	18.5	9.2	19	●	●	●		

¹⁾ IP Protection Class in mated condition.

²⁾ IP Protection Class in unmated condition to the end device.

The Complete ODU Product Range

<p>Single contacts (round or flat)</p>			
<p>High current connectors</p>			
<p>Circular connectors with Push-Pull locking</p>			
<p>Modular rectangular connectors</p>			
<p>PCB connectors</p>			
<p>Robust connectors</p>			
<p>Disposable systems</p>			
<p>Application specific solutions</p>			
<p>AMC - Advanced Military Connector</p>			
<p>Cable assembly</p>			

Everything from one Source: ODU – the System Supplier

Each connection needs its individual cable. Make no compromises when it comes to the quality of the complete connection system. ODU gives you the complete system solution from one source, with no intermediary suppliers.

Cable assembly is a very complex subject. It requires equal measures of expertise in the areas of connectors, cables and assembly. ODU meets all these requirements in full.

Our competent assembly team tests the complete system according to your specifications. Our assembly service promises you the same quality found in our connectors – without compromises.

ODU offers you everything from one source

- 100% final inspections
- Production in clean room according to EN ISO14644-1 possible
- Automated processes (cutting, stripping, attaching)
- Extrusion possible with a hot-melt and high pressure / temperature process
- Ultrasound welding
- EMC-compatible assembly
- Application specific labelling
- Widest range of potting possibilities for sealed systems
- Extruded cable crossovers

Advantages for the customer

- Modern manufacturing facilities in Mühldorf (Germany), Shanghai (China), and Sibiu (Romania)
- Reliability thanks to our company-wide quality strategy
- Products with durability and functional reliability
- Production according to UL (file: E333666) possible
- Inspections, such as crimp force monitoring, during production



Application Specific Connectors



Innovative, dynamic markets call for innovative connectors.

“As an expert for special applications and requirements, we develop forward-looking, appropriate connectors attuned to your needs!”

In spite of the global trend toward standardized connectors, there are always applications that call for an application-specific solution.

We accept this challenge and develop innovative products for our customers based on our many years of extensive know-how, our creativity and, not least, our high level of vertical integration.

Technology access and technology mastery, combined with intensive cooperation with the user, form the basis for achieving success together. Design-to-cost is joined by design-for-application for the customer’s benefit.



Fax Inquiry

Fax-No.: +49 86 31 61 56-49

ODU GmbH & Co. KG
Vertrieb ODU MINI-SNAP® PC
 Pregelstr. 11
 84453 Mühldorf am Inn
 GERMANY

Company: _____
 Name: _____
 Department: _____
 Street: _____
 City: _____
 Phone: _____

Date: _____

We require the following ODU MINI-SNAP® PC miniature circular connectors

1) Connector application			
2) Environment			
3) Connector type	<input type="checkbox"/> Plug	<input type="checkbox"/> Receptacle	<input type="checkbox"/> In-line receptacle
4) Special version			
5) Style			
6) Size	<input type="checkbox"/> 1	<input type="checkbox"/> 2	<input type="checkbox"/> 3
7) Type	<input type="checkbox"/> A	<input type="checkbox"/> C	
8) Coding	<input type="checkbox"/> 1	<input type="checkbox"/> 2	<input type="checkbox"/> 9
9) Colour	<input type="checkbox"/> Grey	<input type="checkbox"/> Black	<input type="checkbox"/> White (On request)
10) Number of positions			
11) Termination	<input type="checkbox"/> Solder	<input type="checkbox"/> Crimp	<input type="checkbox"/> PCB
12) Contact type	<input type="checkbox"/> Stamped contact	<input type="checkbox"/> Turned contact	
13) Cross section of wire		mm ²	AWG
14) Cable diameter		mm	
15) Cable bend relief (colour)			
16) Protection class acc. DIN EN 60 529	<input type="checkbox"/> IP 50 (standard)	<input type="checkbox"/> IP 67	<input type="checkbox"/> other _____
17) Operating temperature		°C max	°C min
18) Electrical specs:			
Operating voltage	_____ V AC	_____ V DC	
Operating current	Continuous _____ A	Short-term _____ A	_____ seconds
19) Chemical resistance against			
20) Other requirements			
21) Autoclavable, 134°C	<input type="checkbox"/> Yes	<input type="checkbox"/> No	
► Required quantity			
► Production quantity			

Please open



ODU GmbH & Co. KG

Pregelstr. 11
84453 Mühldorf a. Inn
Germany

Telefon: +49 8631 6156-0
Telefax: +49 8631 6156-49
E-Mail: zentral@odu.de

ODU France

Telefon: +33 1 3935-4690
E-Mail: odu@odu.fr

ODU Scandinavia

Telefon: +46 176 18261
E-Mail: sales@odu.se

ODU UK

Telefon: +44 1509-266-433
E-Mail: sales@odu-uk.co.uk

ODU USA

Telefon: +1 805 4840540
E-Mail: sales@odu-usa.com

ODU Shanghai Trading

Telefon: +86 21 58347828-106
E-Mail: oduchina@odu.com.cn

You can find more qualified
representatives list on our web page:
www.odu.de/sales