

A PERFECT ALLIANCE.

ODU ELECTRICAL CONTACTS

Contact technologies for the most demanding requirements:
Current-carrying capacity, temperature, mating cycles and more

ODU SPRINGTAC®

ODU LAMTAC®

ODU TURNTAC®



ODU ELECTRICAL CONTACTS

ODU ELECTRICAL CONTACTS

FEATURES

- Versatile contact technologies
- Outstanding reliability and durability with up to 1 million mating cycles
- Current-carrying capacity of up to 2,400 amperes and more
- Robust and universal contact systems
- Stamping technology for customer-specific high volume solutions
- High vibration and shock resistance
- Low, stable contact resistances

APPLICATIONS

- Medical technology
- Test and measurement
- Military and security
- Industrial
- Automotive



All shown connectors are according to IEC 61984:2008 (VDE 0627:2009-11); connectors without breaking capacity (COC).

All dimensions are in mm.

Some figures are for illustrative purposes only. Subject to change without notice. Errors and omissions excepted. We reserve the right to change our products and their technical specifications at any time in the interest of technical improvement. This publication supersedes all prior publications.

This publication is also available as a PDF file that can be downloaded from www.odu-connectors.com

Issue: 2020-04

TABLE OF CONTENTS

Clickable page numbers

THE ODU CORPORATE GROUP	<u>4</u>
PRODUCT INFORMATION	<u>11</u>
Contact technology	<u>12</u>
Contact principle	<u>14</u>
Perfectly connected – our range of services	<u>19</u>
Overview ODU Electrical Contacts	<u>20</u>
Application specific solutions	<u>22</u>
ODU SPRINGTAC®	<u>25</u>
ODU SPRINGTAC® socket with solder / screw termination	<u>26</u>
ODU SPRINGTAC® socket with crimp termination	<u>27</u>
ODU SPRINGTAC® socket with outer thread	<u>28</u>
ODU contact pin with solder / screw termination	<u>29</u>
ODU contact pin with crimp termination	<u>30</u>
ODU SPRINGTAC® externally flexed contact pin with solder / screw termination	<u>31</u>
ODU SPRINGTAC® FLATSOCKETS	<u>33</u>
ODU SPRINGTAC® Flatsocket for 2-wire measurement, with crimp termination	<u>34</u>
ODU SPRINGTAC® Flatsocket for 2-wire measurement, ODU QCH [quick-change head]	<u>35</u>
ODU SPRINGTAC® Flatsocket for 4-wire measurement [Kelvin measurement], with solder termination	<u>36</u>
ODU LAMTAC®	<u>39</u>
ODU LAMTAC® socket with solder / screw termination	<u>40</u>
ODU LAMTAC® socket with crimp termination	<u>41</u>
ODU LAMTAC® socket with outer thread	<u>42</u>
ODU contact pin with solder / screw termination	<u>44</u>
ODU contact pin with crimp termination	<u>45</u>
ODU TURNTAC®	<u>47</u>
ODU TURNTAC® socket with solder / screw termination	<u>48</u>
ODU TURNTAC® socket with crimp termination	<u>49</u>
ODU contact pin with solder / screw termination	<u>50</u>
ODU contact pin with crimp termination	<u>51</u>
TOOLS AND ACCESSORIES	<u>53</u>
Termination technologies	<u>54</u>
Crimping tools	<u>56</u>
Conversions / AWG	<u>60</u>
Service Kit	<u>61</u>
TECHNICAL INFORMATION	<u>63</u>
Current-carrying capacity	<u>64</u>
Installation instructure	<u>68</u>
Chamber dimensions for ODU SPRINGTAC® Flatsocket	<u>70</u>
Technical terms	<u>72</u>

A PERFECT ALLIANCE

Creating connections, building alliances, collaborating into the future: Whether two technical components come together to form a unit or people come together to strive for great results – the key is to aspire to achieve superb results. This goal drives our work. **Perfect connections that inspire and deliver on the promises.**



ODU GROUP OVERVIEW

- Almost 80 years of experience in connector technology
- Over 2,300 employees worldwide
- Sales subsidiaries in China, Denmark, France, Germany, Hong Kong, Italy, Japan, Korea, Romania, Sweden, UK and the US as well as 5 production and logistics sites
- All technologies under one roof: Design and development, machine tool and special machine construction, injection, stamping, turning, surface technology, assembly and cable assembly

As of February 2020

CERTIFICATES & APPROVALS

- ISO 9001
- IATF 16949
- ISO 13485
- ISO 14001
- ISO 50001
- Wide range of UL, CSA, VG and VDE approvals
- UL Wiring Harnesses certified

For a complete list of our certifications and approvals, please visit our website.

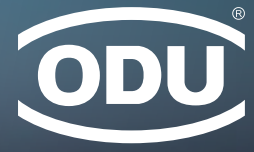

WORLDWIDE CUSTOMER PROXIMITY

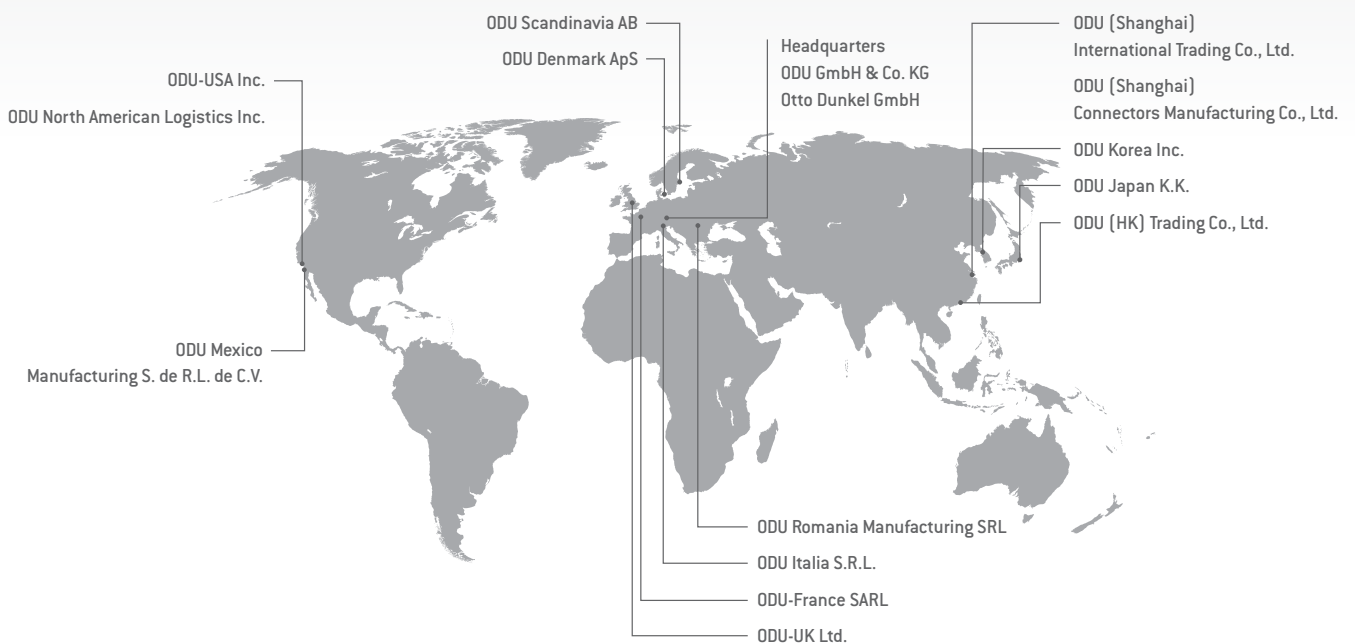

CONNECTIONS THAT LIVE UP TO ANY REQUIREMENT



ELECTRICAL CONTACTS

- Versatile contact technologies
- Outstanding reliability and durability
- Current-carrying capacity of up to 2,400 A
- Rugged and universal contact systems
- Stamping technology for customer-specific high volume solutions
- Very high vibration resistance
- Low, stable contact resistance

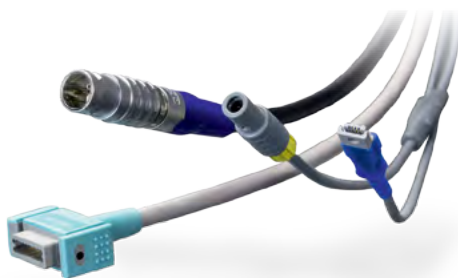

CABLE ASSEMBLY

- Complete system solutions from one source based on years of expertise
- State-of-the-art production facilities with 100 % end testing
- Cable assembly available for ODU products
- Overmolding in silicone, hot-melt and high-pressure procedures
- Customer-specific labeling and cable printing
- Wide range of standard cables and accessories available
- Prototype, small series and high volume production
- Rapid prototyping



CIRCULAR CONNECTORS

- Circular connector series in robust metal or plastic housing
- Contacts for soldering, crimping and PCB termination
- Different locking systems available: Push-Pull and Screw-Locking options or Break-Away function for quick release
- 2 up to 55 contacts
- Protection classes IP50 to IP69
- Autoclavable for medical applications
- Hybrid inserts for combined transmission
- Including cable assembly – system solution from one source



APPLICATION AND CUSTOMER-SPECIFIC SOLUTIONS

- Contacts, connectors and cable assemblies for the highest technical requirements as well as special applications
- First-class implementation expertise
- High level of vertical manufacturing – all competences and key technologies under one roof
- Expert advice based on mutual partnership
- Short development and production paths



MODULAR CONNECTORS

- Application-specific hybrid interface
- For manual mating and automatic docking
- Flexible modular construction and highest packing density
- For the transmission of signals, power, high current, high voltage, HF signals (coax), media, high-speed data or fiber optics
- Variety of locking options available
- Mating cycles scalable as required from 10,000 to over 100,000 (1 million)
- Including cable assembly – system solution from one source



MASS INTERCONNECT SOLUTIONS

- For testing printed circuit boards (PCBs) and electronically assembled units
- Innovative engagement option: electromechanical version
- 8 tensioning points stop the frame distorting
- Very high flexibility thanks to ODU-MAC® modules
- Adapter frame (ITA) with tolerance compensation
- Including cable assembly – system solution from one source



HEAVY DUTY CONNECTORS

- Extremely durable even under extreme / harsh environments
- High vibration resistance
- Up to 400 A (higher currents upon request)



PRINTED CIRCUIT BOARD CONNECTORS

- Maximum flexibility in application designs
- High resilience and outstanding quality
- Including cable assembly – system solution from one source

OUR KNOW-HOW FOR YOUR SUCCESS

Customers rely on ODU technology wherever first-class, high-performance connector solutions are required.

All our skills go into our products to ensure your success.

In addition to the top quality, reliable stability and maximum flexibility our products also stand for **dynamics, reliability, safety, precision, efficiency and sustainability.**

HIGH PERFORMANCE CONNECTOR TECHNOLOGY FOR DEMANDING KEY MARKETS

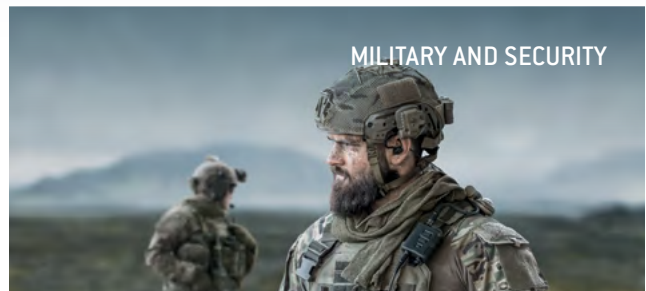

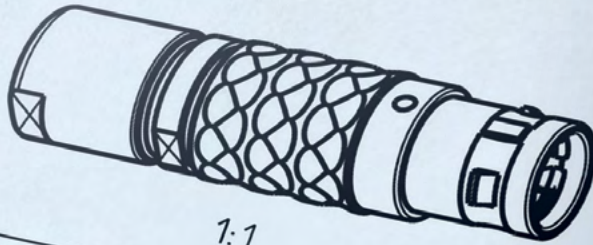

S12L_C-P03MSNO-9900	> 9.0 - 9.9 mm
S12L_C-P03MSNO-9200	> 8.0 - 9.2 mm
S12L_C-P03MSNO-8200	> 7.0 - 8.2 mm
S12L_C-P03MSNO-7200	> 6.0 - 7.2 mm
S12L_C-P03MSNO-6200	> 5.0 - 6.2 mm
S12L_C-P03MSNO-5200	> 4.0 - 5.2 mm

MORE THAN A CONNECTION

Contacts, connectors and cable assembly system solutions meeting the most demanding technical market requirements – ODU’s connector solutions and value-added services are characterized by their exclusive focus on meeting the customer’s needs.

- Precise implementation of application-specific requirements regarding design, functionality, cost and exclusivity
- Modified connector solutions derived from standard products
- One-to-one local expertise and fair, friendly consulting
- Short development and production paths

DEVELOPMENT OF CUSTOM SOLUTIONS

Demands that can’t be pigeon-holed call for creative specialists who think outside the box. ODU offers the type of expertise that focuses solely on the specific requirements of our customers.

For every development order we get, we not only perform a thorough check to make sure it’s feasible, we intensively incorporate our customers in the ongoing design process.

This guarantees impressive, custom-fit final end products.

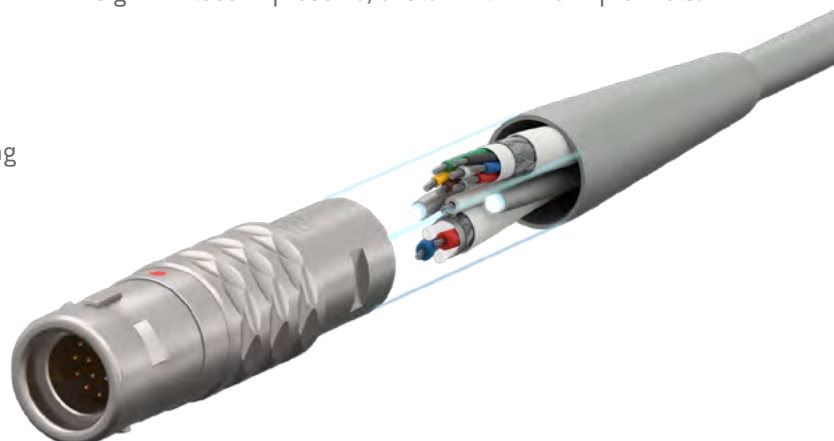



ODU ELECTRICAL CONTACTS



PRODUCT INFORMATION

Contact technology	<u>12</u>
Contact principle	<u>14</u>
Perfectly connected – our range of services	<u>19</u>
Overview ODU Electrical Contacts	<u>20</u>
Application specific solutions	<u>22</u>

CONTACT TECHNOLOGIES FOR A WIDE VARIETY OF SPECIFICATIONS

ODU's extensive product portfolio offers highly specialized contact types. The functionality and properties of each contact system have been precisely geared to each specific application. They are available in a wide range of dimensions and termination types.

ODU LAMTAC®

Maximum current-carrying capacity and temperature resistance

ODU STAMPTAC®

Stamping technology for customer-specific high volume solutions

ODU SPRINGTAC® FLATSOCKET

Optimal contacting for reliable results

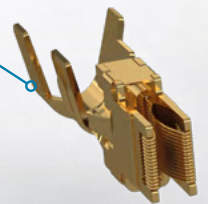

ODU TURNTAC®

Rugged and universal contact system

ODU SPRINGTAC®

Outstanding reliability and durability

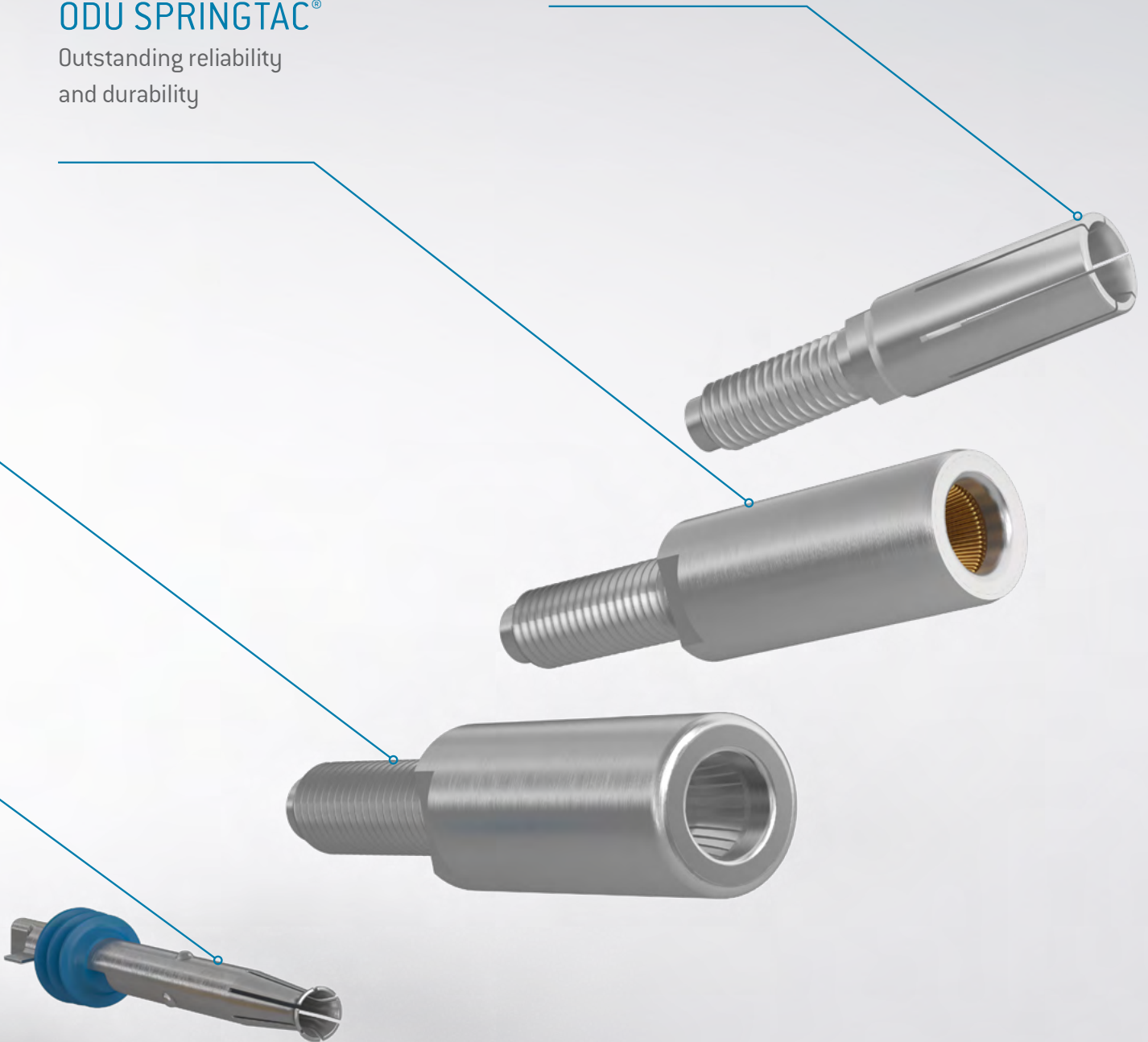

Find out more at www.odu-connectors.com/electrical-contacts



BEST CONNECTIONS – THE CONTACT PRINCIPLE

Electrical Contacts from ODU meet the highest quality standards and ensure secure and reliable connections. Behind this achievement are 80 years of experience in the electrical connector technology. In addition to the springwire and the lamella technology ODU also offers turned, slotted contact systems and stamping technology for a wide variety of specifications.

ODU LAMTAC®

Contacts with lamella technology

ODU LAMTAC® is a high-performance contact system with lamella technology. It has a high current-carrying capacity and can be used at temperatures of up to +150 °C (and higher temperatures on request). It consists of a turned carrier containing one or several stamped lamella belts. The lamella's individual louvres make for a multitude of contact points, thereby guaranteeing a high level of contact safety and ease of connecting.

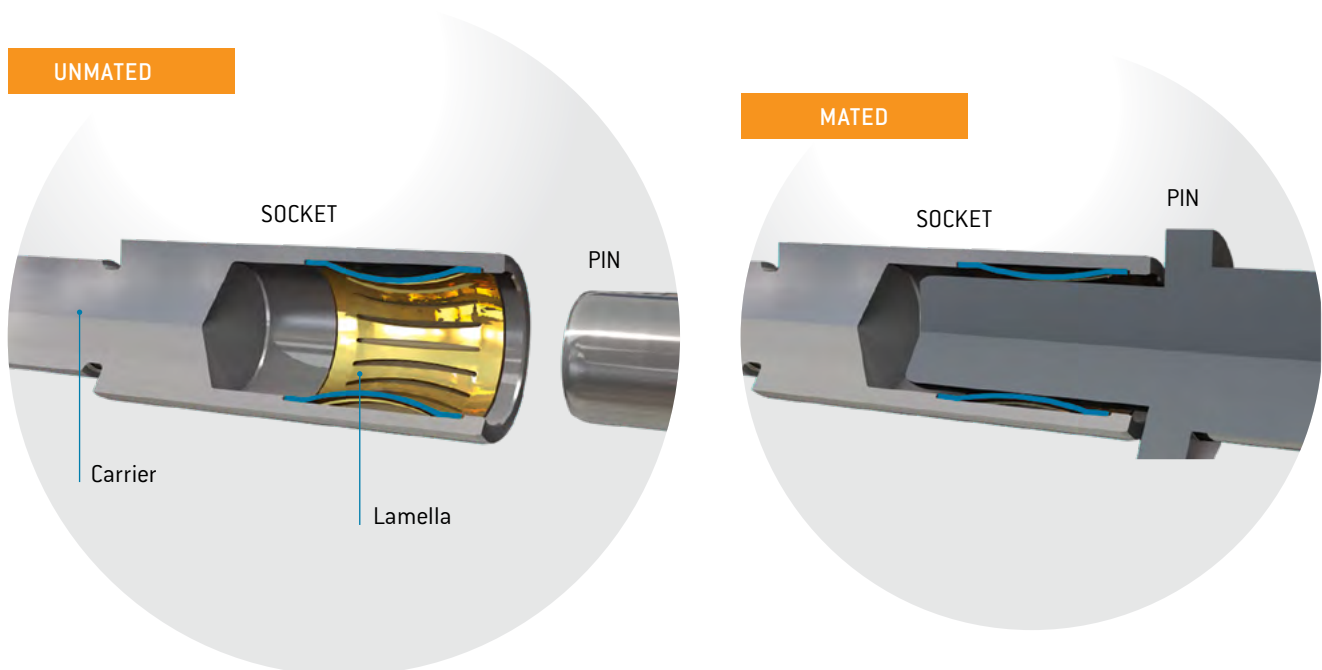

BENEFITS

- Current-carrying capacity of up to 2,400 amperes (on request)
- > 10,000 mating cycles
- High vibration and shock resistance
- Low contact resistance
- Automated lamella assembly
- High contact security

ODU SPRINGTAC®

Contacts with springwire technology

ODU SPRINGTAC® is the most effective contact system on the market. It offers maximum reliability and an exceptionally long durability. Due to the many independent wire springs, constant transmission is ensured at all times. Even the smallest contact, at 0.76 mm in diameter, contains 15 individual springs. In other words, 15 contact surfaces are present in this tiny contact area.

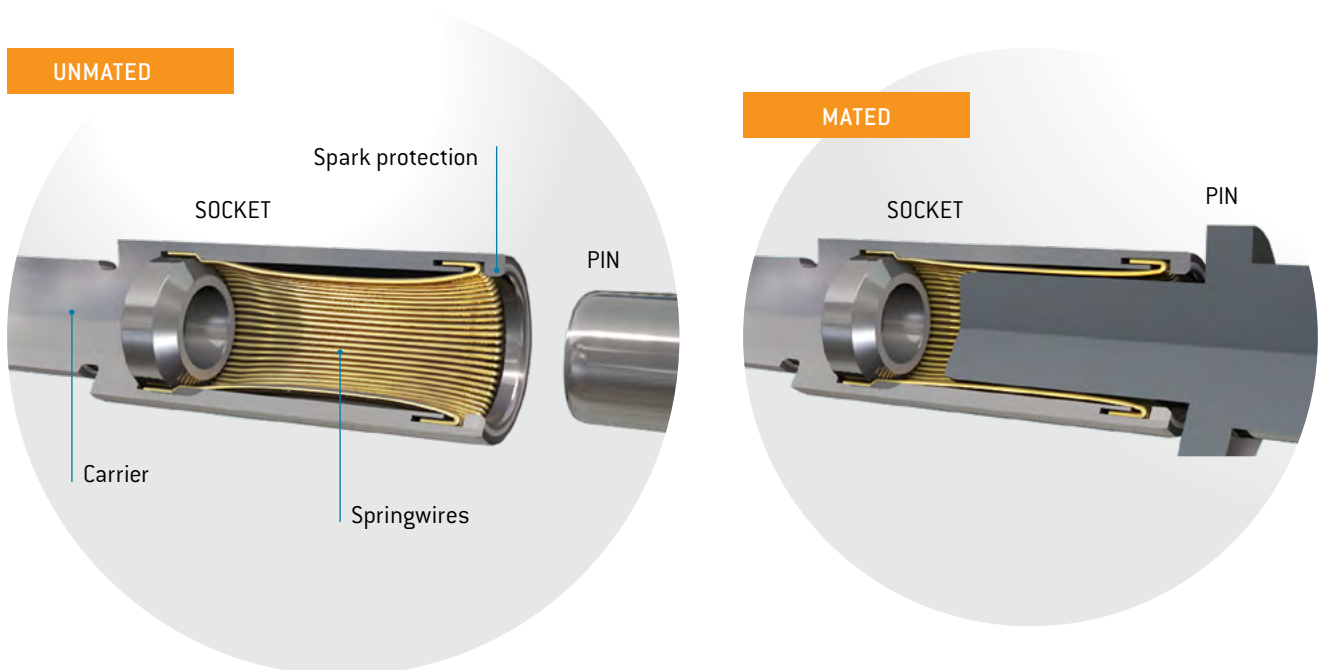

BENEFITS

- Outstanding reliability and durability with up to 1 million mating cycles (on request)
- Very high contact security
- Low mating and demating forces
- High vibration and shock resistance
- Low contact resistance
- High current-carrying capacity

ODU SPRINGTAC® Flatsocket

Flatsockets with springwire technology

For many components and assemblies, simple low-cost flat contacts or square pins are used. These kinds of connectors have not been created with a focus on a high number of mating cycles, as they are only demated for servicing. But for the quality control during the serial production high mating cycles are needed.

The ODU SPRINGTAC® Flatsocket with springwire technology is the perfect, long-lived counterpart for testing purposes. Its low, stable resistance values make it suitable for sensitive measuring tasks as well as for the testing of high current-carrying capacity.



BENEFITS

- Ideal for test adapters
- Optimal contacting for reliable results
- > 50,000 mating cycles
- Versions for 2-wire and 4-wire measurement
- Functional ODU quick-change head (QCH) principle

THE ODU QUICK-CHANGE HEAD QCH (CONNECTOR SAVER) PRINCIPLE

With the ODU quick-change head QCH (connector saver) principle, the socket has a contact pin termination instead of a conventional cable termination. The contact pin can be mated with an ODU SPRINGTAC® or ODU LAMTAC® socket installed in an assembled connector (base part). Sockets with a QCH termination are integrated in an insulator (interchangeable part) which can be front-mounted to the connector.

This way, you can quickly and easily exchange the test adapter without any further assembly.

The use of a wide variety of exchange components provides you with a maximum amount of flexibility for your production.

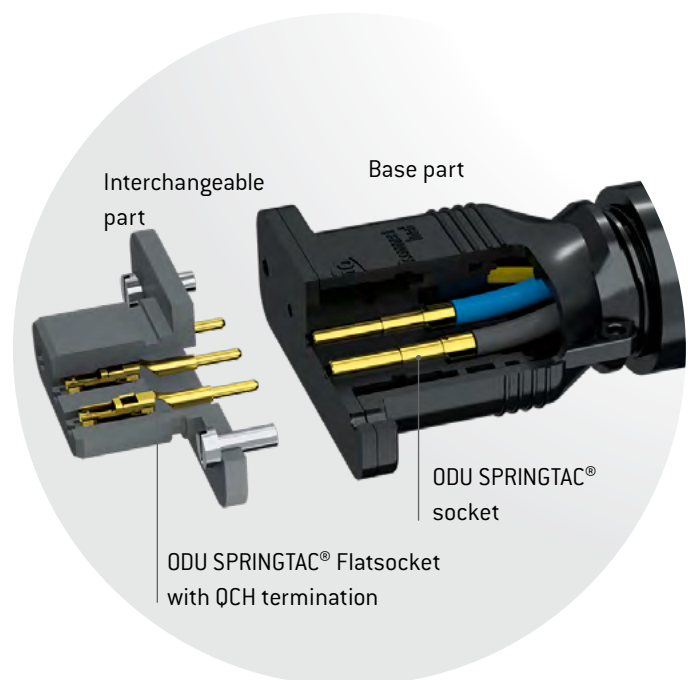
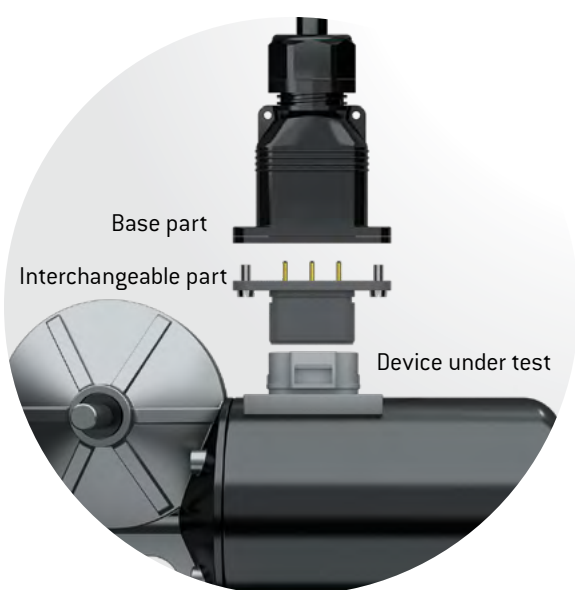

PROGRESS IN TESTING TECHNOLOGY

Stamped flat contacts (pins) are widely used in automotive electronics and equipment engineering. In standard series connectors, the counterpart consists of stamped sockets crimped to the cables and locked into the insulator. These stamped socket contacts typically allow for only a few mating cycles and are practically unsuitable for testing. This is also because of their often strong mating and demating forces.

ODU SPRINGTAC® Flatsockets have been specifically developed for measuring and testing technology. They allow for over 50,000 mating cycles and reliably transmit even very high test currents. Combined with the ODU quick-change head QCH (connector saver) principle, many million mating cycles can be achieved.

ODU TURNTAC®

Contacts in slotted version

The universal ODU TURNTAC® contact system combines the very best contact properties and high quality with economical prices. It has stood the test of even the toughest application areas. The contact principle can even be used in dimensions as tiny as 0.3 mm in diameter. The slotted contact offers two to six contact areas, depending on the version.

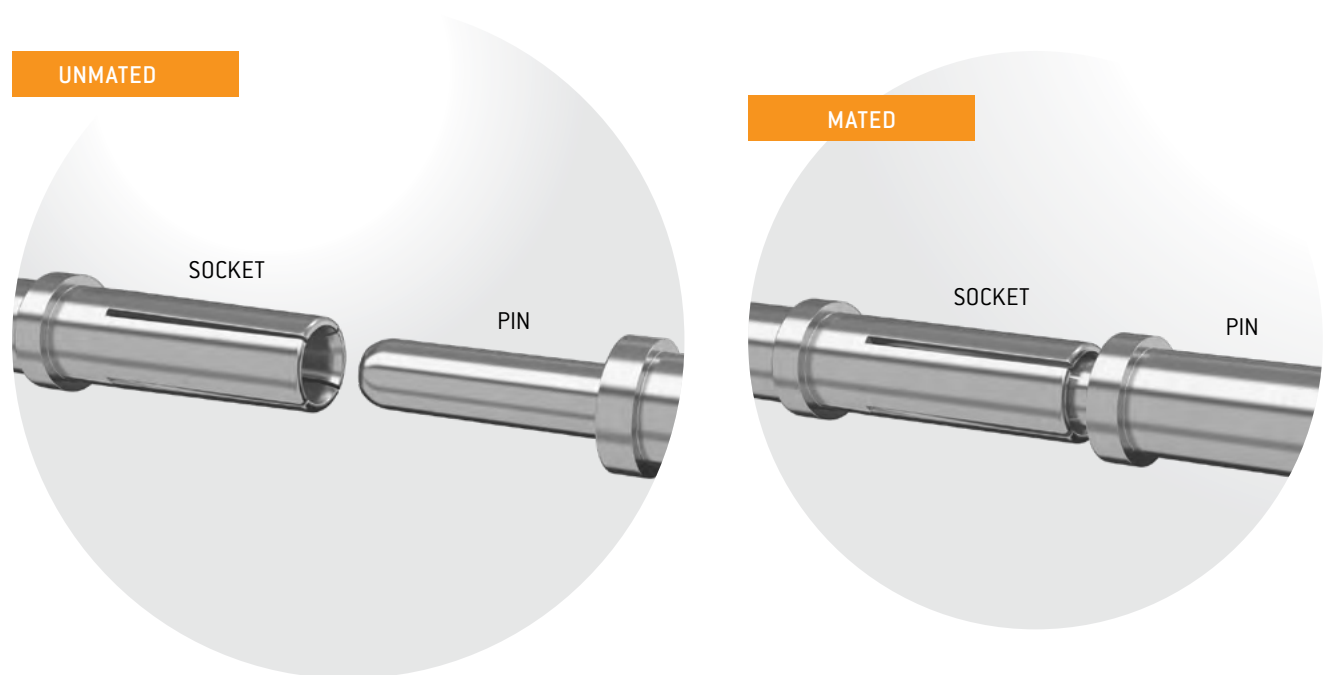

BENEFITS

- Turned, slotted contacts
- Rugged and universal contact system
- > 10,000 mating cycles
- Low and stable mating and demating forces
- Tiniest dimensions possible, down to 0.3 mm contact diameter (on request)
- Mating possible at an angle of up to 5°

BEST CONNECTIONS – OUR RANGE OF SERVICES

EVERYTHING FROM ONE SOURCE

The perfect connector system offers a perfect interplay of the contact, termination technology and cable assembly. Additional components and services are available as custom solutions. We offer the following service for complete solutions:

- + Cable assembly
- + Overmolding solutions
- + Additional components and complete units

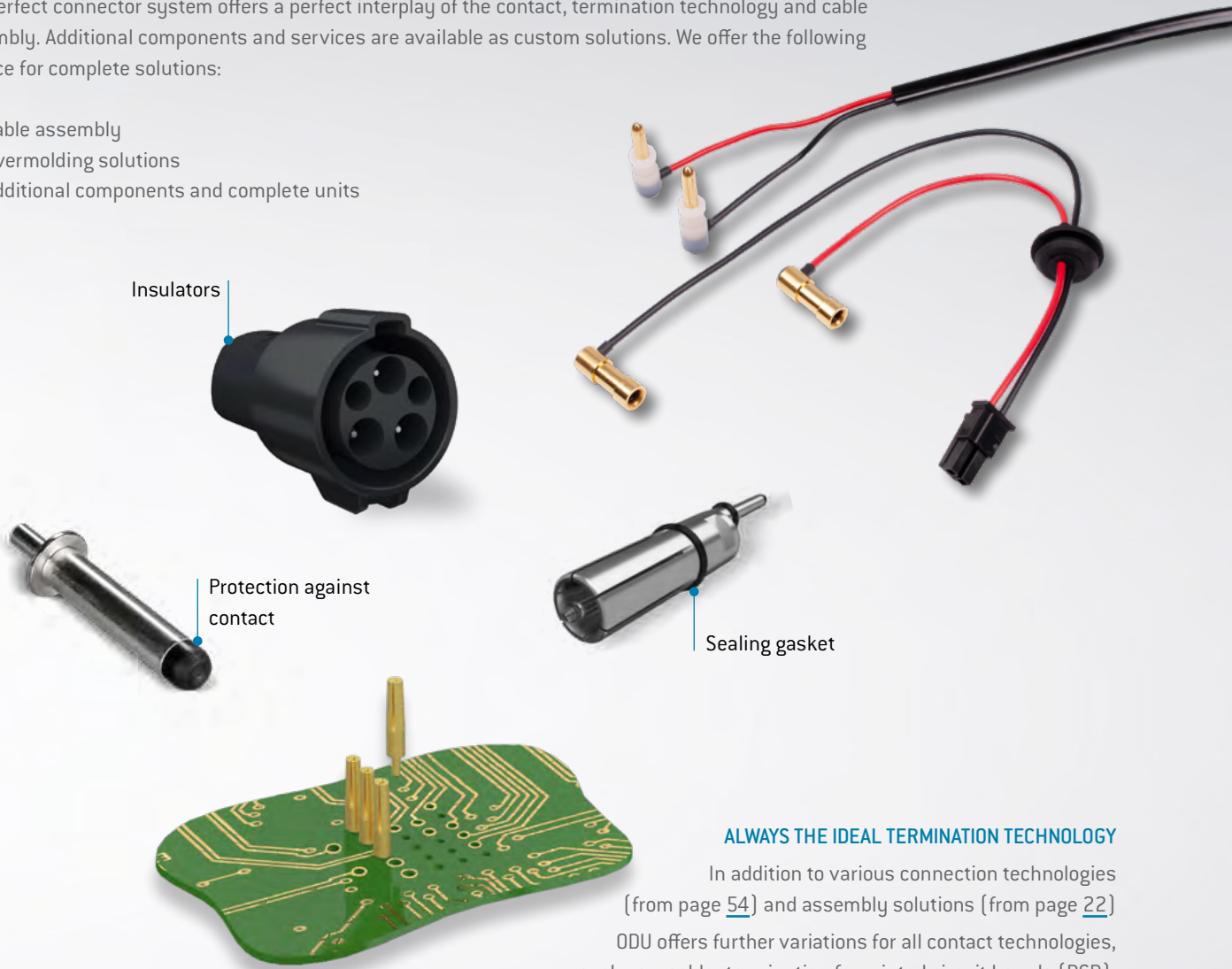

Insulators

Protection against contact

Sealing gasket

ALWAYS THE IDEAL TERMINATION TECHNOLOGY

In addition to various connection technologies (from page 54) and assembly solutions (from page 22) ODU offers further variations for all contact technologies, such as a solder termination for printed circuit boards (PCB).

CUSTOMIZED STAMPING SOLUTIONS

As a cost-effective alternative for high quantities, ODU STAMP TAC® technology combines optimal contact design with stamping technology. An ideal design for automated processing in large production series, both complex geometries and overall system solutions can be implemented.

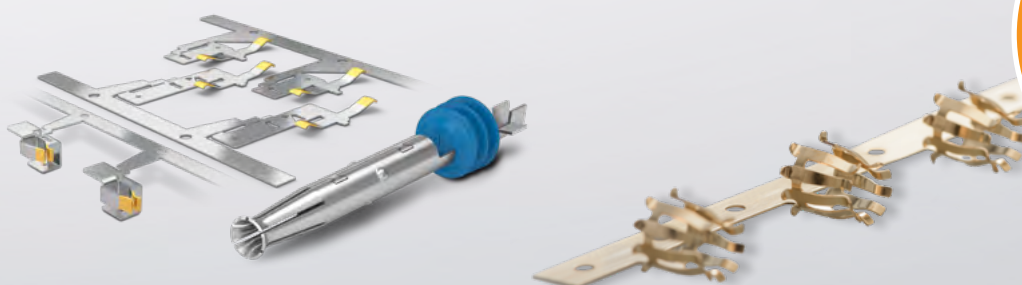

WANT TO KNOW MORE?
electrical-contacts@odu.de

OVERVIEW ODU ELECTRICAL CONTACTS

ODU Electrical contacts create perfect connections. From simple applications to complex specifications and even in the toughest environmental conditions – our contacts offer ideal solutions. Including the highest level of contact safety and reliability.

Our portfolio includes universal contact varieties with a practical crimp terminal as well as a solder/screw terminal. Our sockets with an external thread allow you to integrate our time-tested contact technology even in the tightest of installation spaces.

Our sockets are ideally complemented with our ODU contact pins for a maximum service life and perfect contacts.

ODU SPRINGTAC® SOCKETS AND PINS P. 26





- 

ODU SPRINGTAC® socket
Solder / screw termination
- 

ODU SPRINGTAC® socket
Crimp termination
- 

ODU SPRINGTAC® socket
Outer thread
- 

ODU contact pin
Solder / screw termination
- 

ODU contact pin
Crimp termination
- 

Externally flexed contact pin
Solder / screw termination

ODU SPRINGTAC® FLATSOCKETS P. 34

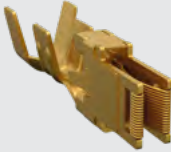

- 



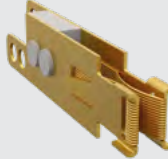



ODU SPRINGTAC® Flatsocket
Crimp termination
- 

ODU SPRINGTAC® Flatsocket
QCH quick-change head
- 

ODU SPRINGTAC® Flatsocket
Solder termination





ODU LAMTAC® SOCKETS AND PINS P. 40



	ODU LAMTAC® socket Solder / screw termination
	ODU LAMTAC® socket Crimp termination
	ODU LAMTAC® socket Outer thread
	ODU LAMTAC® socket Outer thread
	ODU contact pin Solder / screw termination
	ODU contact pin Crimp termination

ODU TURNTAC® SOCKETS AND PINS P. 48

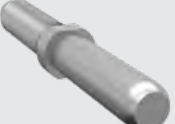

	ODU TURNTAC® socket Solder / screw termination
	ODU TURNTAC® socket Crimp termination
	ODU contact pin Solder / screw termination
	ODU contact pin Crimp termination

APPLICATION-SPECIFIC SOLUTIONS

When standard solutions reach their limits, it's time to bring in the specialists who can think outside the box to find creative solutions. ODU has experts like this – and they'll put all their focus on your specific needs. We do more than simply carry out a feasibility test for each development contract. We also closely collaborate with our customers throughout the design process. This way, we can guarantee impressive customized results. Our custom solutions are often based on modifications of standard solutions.

CUSTOMIZED CONNECTORS

The angled ODU pin contact connects a ODU TURNTAC® socket, which connects the module block to a battery storage system. The ODU product, which we manufacture right down to the cable assembly, guarantees easy installation, proven current-carrying capacity and touch protection – and also ensures perfect connections.

Advantages

- Complete solution from one source
- Over 10,000 mating cycles
- With break-away function



THE CONTACT MAKES THE DIFFERENCE

The universal properties of the ODU TURNTAC® typically make it the number one choice for connectors in automation or other industrial applications. Even the smallest of dimensions allow for high contact density. The sophisticated contact technology combined with our surface engineering enable reliable contacting even in the most challenging operating conditions.

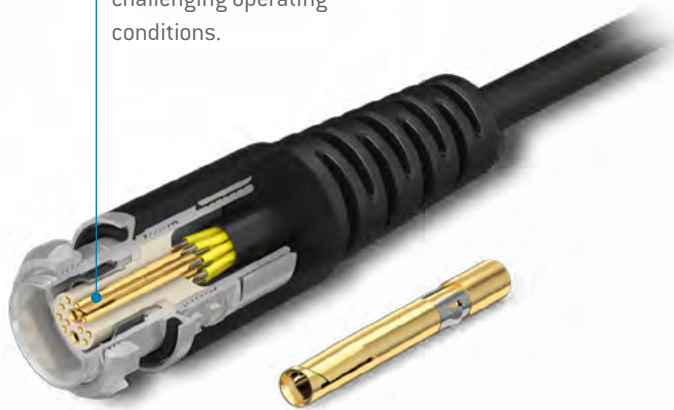

CHARGING CONNECTORS

The ODU STAMPTAC® is equipped with additional attractive features beyond those of the ODU TURNTAC®. These features make it particularly suited for use in chargers. Thanks to the punched-rolled manufacturing method, this contact is ideal for automated processing which is crucial for large quantities. The integrated overmolded three-lip seal guarantees that sealing class IP67 is met and provides additional efficiency benefits at the same time.



1 MILLION MATING CYCLES

Our ODU SPRINGTAC® offers top performance for welding current transmission in a tool-changing system. An intelligent crimp termination system ensures maximum flexibility in the tiniest of installation spaces – as well as one million mating cycles.



HIGHEST CURRENT-CARRYING CAPACITY AND VIBRATION RESISTANCE

For an electric surfboard, a connection is needed that is very powerful and also vibration and shock resistant. An ODU LAMTAC® contact is the perfect solution here. A permanently secure connection is created thanks to its high current-carrying capacity as well as the lamella louvres, which create a large number of contact points. The customized solution based on ODU LAMTAC® contact technology serves as an interface between the speed controller, the motor and the battery.



ODU LAMTAC® ON THE TEST BENCH

The reliable transmission of high performance under climate changing conditions demand high requirements to the contact system and connection technology. ODU LAMTAC® combines this in this docking solution in an extraordinary way.

Advantages

- System solution from one source
- Low coupling forces
- Temperature stable connection

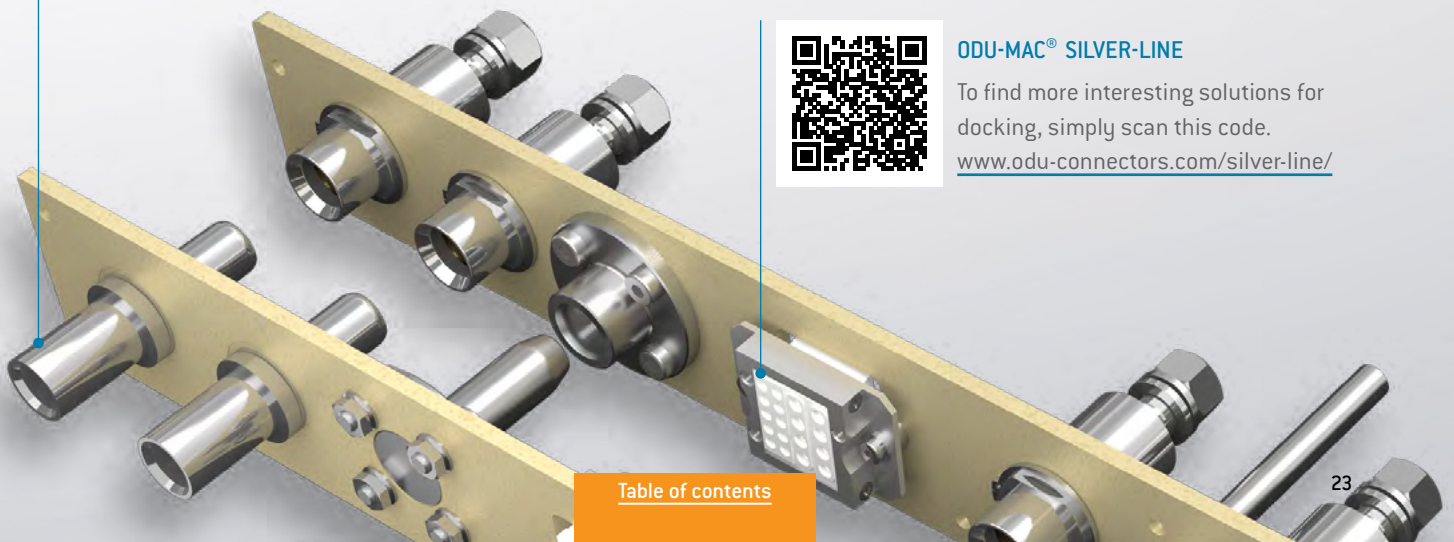

ODU-MAC® SILVER-LINE

To find more interesting solutions for docking, simply scan this code.
www.odu-connectors.com/silver-line/



ODU ELECTRICAL CONTACTS



ODU SPRINGTAC®

- ODU SPRINGTAC® socket with solder / screw termination [26](#)
- ODU SPRINGTAC® socket with crimp termination [27](#)
- ODU SPRINGTAC® socket with outer thread [28](#)
- ODU contact pin with solder / screw termination [29](#)
- ODU contact pin with crimp termination [30](#)
- ODU SPRINGTAC® externally flexed contact pin with solder / screw termination [31](#)

ODU SPRINGTAC® SOCKET



Contact with springwire technology

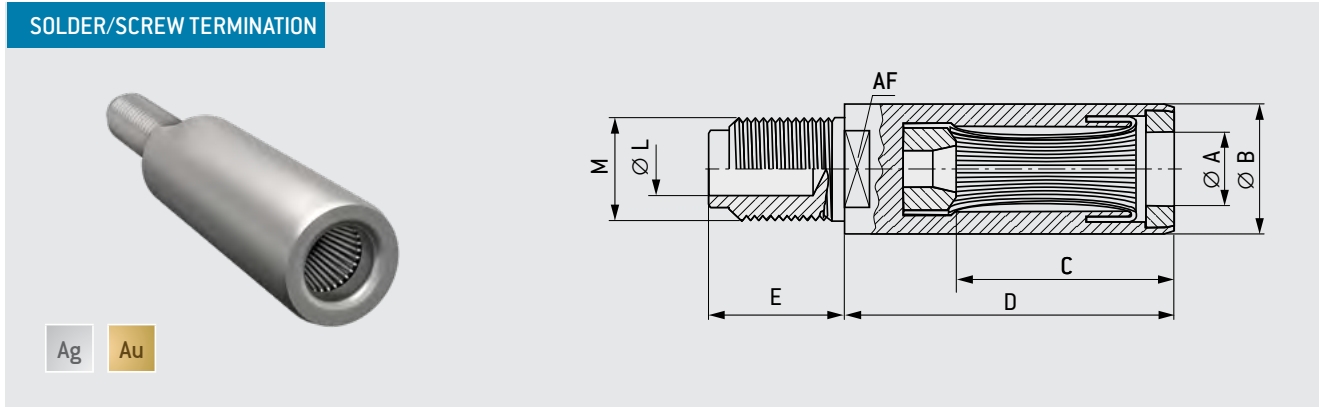

Part number	Surface	Dimensions									Mechanical data ¹		Electrical data ¹			
		Ø A	Ø B	C	D	AF	E	M	Ø L ¹	Q ¹	Mating force	Demating force	Nominal current	Max. cont. current	Surge Current	Contact resistance
		mm	mm	mm	mm	mm	mm	Thread	mm	mm ²	N	N	A	A	kA	µΩ
170.106.100.201.000	Ag	1.5	4	12	15.5	–	12.5	M2.6	1.25	1.5	5	3	25	35	1.5	500
170.106.700.207.000	Au															
170.107.100.201.000	Ag	2	4	12	15.5	–	12.5	M3	1.8	2.5	6	4	30	45	2.5	400
170.107.700.207.000	Au															
170.109.100.201.000	Ag	2.5	6	12	15.5	5	12.5	M3	1.8	2.5	8	5	30	45	3	300
170.109.700.207.000	Au															
170.110.100.201.000	Ag	3	7	15	22.5	5	15	M4	2.3	4	10	7	40	65	4	250
170.110.700.207.000	Au															
170.111.100.201.000	Ag	4	8	15	22.5	6	19	M5	3	6	15	10	55	80	7	210
170.111.700.207.000	Au															
170.112.100.201.000	Ag	5	9	15	22.5	7	19	M5	3	10	18	12	75	115	10	200
170.113.100.201.000	Ag	6	11	24	33.5	8	22	M6	3.6	16	20	13	100	145	13	180
170.115.100.201.000	Ag	8	14	24	33.5	11	26	M8	4.8	25	25	15	140	200	18	160
170.117.100.201.000	Ag	10	16	24	33.5	12	30	M10	6.2	35	30	20	175	265	25	150
170.119.100.201.000	Ag	12	18	36	47	14	34	M12 × 1.5	7.6	50	35	25	230	345	34	140
170.121.100.201.000	Ag	16	23	36	47	19	42	M16 × 1.5	11.5	95	45	35	340	465	50	130
170.123.100.201.000	Ag	20	27	48	66	22	50	M20 × 2	14.5	150	55	45	450	605	70	115
170.125.100.201.000	Ag	24	32	48	66	27	58	M24 × 2	17.8	240	70	55	500	705	90	105
170.127.100.201.000	Ag	28	36	48	66	32	62	M32 × 2	25	400	90	65	650	855	110	90
170.128.100.201.000	Ag	30	38	48	66	32	62	M32 × 2	25	500	100	70	720	955	120	80

Other variants, dimensions and finishes available on request.

¹ See "Technical Information" starting on page 63

SPECIFICATIONS

- Suitable for contact pins (page 29 and 30)
- For tightening torque see page 59
- Suitable for screwing to power busbars, backplanes and contact blocks
- Cables with lugs can be easily connected.
- Cables can be soldered into the solder hole.

ODU SPRINGTAC® SOCKET



Contact with springwire technology

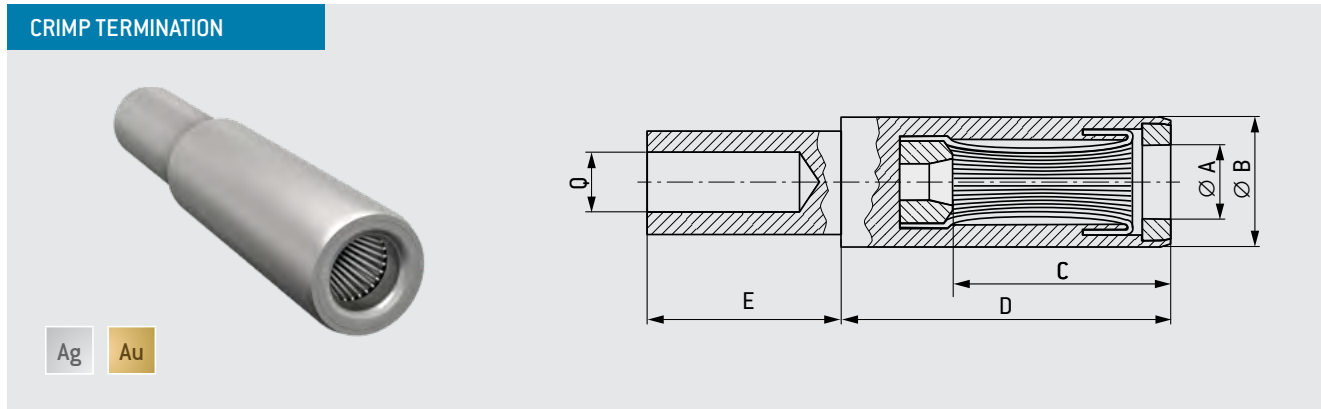

Part number	Surface	Dimensions						Mechanical data ¹		Electrical data ¹			
		Ø A mm	Ø B mm	C mm	D mm	E mm	Q ¹ mm ²	Mating force N	Demating force N	Nominal current A	Max. continuous current A	Surge current kA	Contact resistance µΩ
170.361.700.207.000	Au	0.76	1.58	7	9.8	5	0.38	1.5	1	10	15	0.7	3,000
170.362.700.207.000	Au	1.02	1.98	7	9.8	5	0.5	2	1.5	12	18	1	2,000
171.606.100.201.000	Ag	1.5	4	12	15.5	6.5	1.5	5	3	25	35	1.5	500
171.606.700.207.000	Au												
171.607.100.201.000	Ag	2	4	12	15.5	6.5	2.5	6	4	30	45	2.5	400
171.607.700.207.000	Au												
171.609.100.201.000	Ag	2.5	6	12	15.5	6.5	2.5	8	5	30	45	3	250
171.609.700.207.000	Au												
170.610.100.201.000	Ag	3	5.5	15	22.5	6.5	2.5	10	7	30	45	4	220
170.610.700.207.000	Au												
171.610.100.201.000	Ag	3	7	15	22.5	6.5	4	10	7	40	65	4	220
171.610.700.207.000	Au												
170.611.100.201.000	Ag	4	8	15	22.5	12.5	4	15	10	40	65	4	210
170.611.700.207.000	Au												
171.611.100.201.000	Ag	4	8	15	22.5	12.5	6	15	10	55	80	7	210
171.611.700.207.000	Au												
171.612.100.201.000	Ag	5	9	15	22.5	17.5	10	18	12	75	115	10	200
171.613.100.201.000	Ag	6	11	24	33.5	22.5	16	20	13	100	145	13	180
171.615.100.201.000	Ag	8	14	24	33.5	22.5	25	25	15	140	200	18	160
171.617.100.201.000	Ag	10	16	24	33.5	22.5	35	30	20	175	265	25	150
171.619.100.201.000	Ag	12	18	36	47	28	50	35	25	230	345	34	140
171.621.100.201.000	Ag	16	23	36	47	28	95	45	35	340	465	50	130

Other variants, dimensions and finishes available on request.

¹ See "Technical Information" starting on page 63

SPECIFICATIONS

- Suitable for contact pins (page 29 and 30)
- Easy and quick termination by crimping (crimp information starting on page 54)
- Suitable for connecting harmonized cables
- Part number crimping tool see table on page 56

ODU SPRINGTAC® SOCKET



Contact with springwire technology

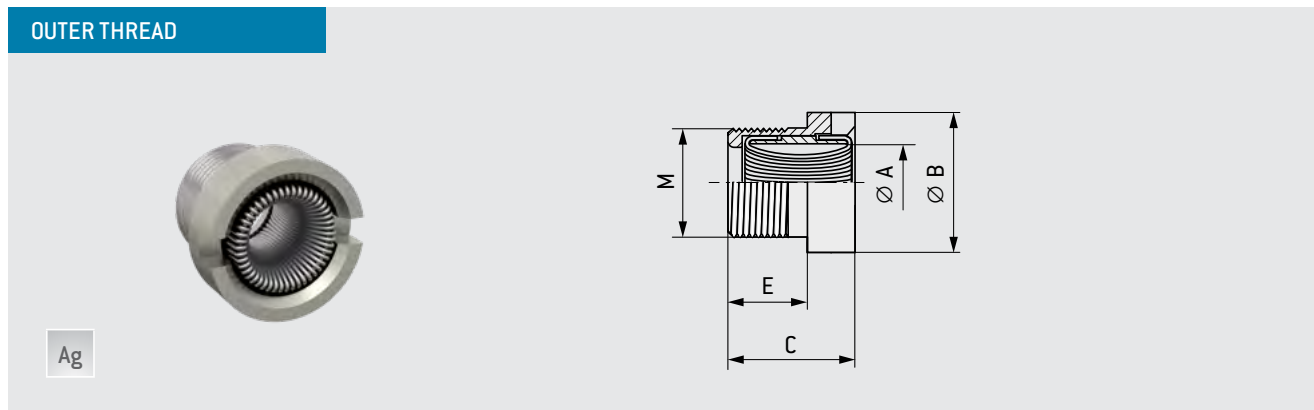

Part number	Dimensions					Mechanical data ¹			Electrical data ¹			
	Ø A	Ø B	C	E	M	Mating force	Demating force	Tightening torque	Nominal current	Max. continuous current	Surge current	Contact resistance
	mm	mm	mm	mm	Thread	N	N	Nm	A	A	kA	µΩ
174.011.000.201.000	4	9	8	5	M7 × 0.5	6.5	5	1.2	45	80	7	320

Other variants, dimensions and finishes available on request.

¹ See "Technical Information" starting on page [63](#)

SPECIFICATIONS

- Suitable for contact pins (page [29](#) and [30](#))
- Suitable for screwing to power busbars, backplanes and contact blocks
- Can be connected at both ends

ODU CONTACT PIN

For all ODU SPRINGTAC® sockets

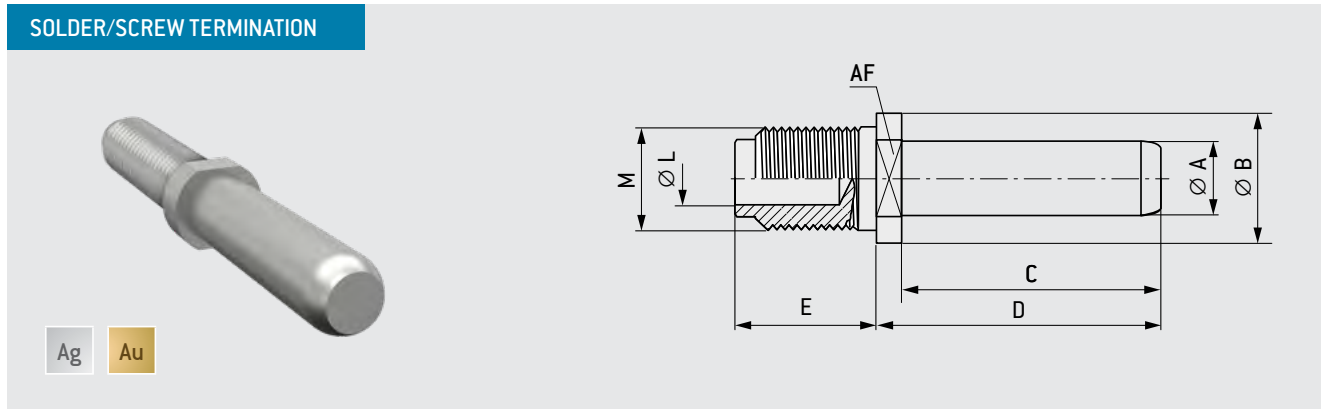

Ag Au

Part number	Surface	Dimensions								
		Ø A mm	x ¹ mm	Ø B mm	C mm	D. mm	AF mm	E mm	M Thread	Ø L ¹ mm
181.106.000.301.000	Ag	1.5	-0.03	4	10	11.5	3	10	M2.6	1.25
181.106.000.307.000	Au									
181.107.000.301.000	Ag	2	-0.03	5	10	11.5	4	12.5	M3	1.8
181.107.000.307.000	Au									
181.109.000.301.000	Ag	2.5	-0.03	5	10	11.5	4	12.5	M3	1.8
181.109.000.307.000	Au									
181.110.000.301.000	Ag	3	-0.03	6	14	15.5	5	15	M4	2.3
181.110.000.307.000	Au									
181.111.000.301.000	Ag	4	-0.03	7	14	16	6	19	M5	3
181.111.000.307.000	Au									
181.112.000.301.000	Ag	5	-0.03	7	14	16	6	19	M5	3
181.113.000.301.000	Ag	6	-0.03	8	23	26	7	22	M6	3.6
181.213.000.301.000	Ag	6	-0.03	11	23	26	8	22	M8	4.8
181.115.000.301.000	Ag	8	-0.03	11	23	26	9	26	M8	4.8
181.215.000.301.000	Ag	8	-0.03	14	23	26	11	26	M10	6.2
181.117.000.301.000	Ag	10	-0.04	16	23	26	12	30	M10	6.2
181.217.000.301.000	Ag	10	-0.04	16	23	26	12	30	M12 × 1.5	7.6
181.119.000.301.000	Ag	12	-0.04	16	34	38	14	34	M12 × 1.5	7.6
181.121.000.301.000	Ag	16	-0.04	20	34	38	17	42	M16 × 1.5	11.5
181.123.000.301.000	Ag	20	-0.04	25	46	51	22	50	M20 × 2	14.5
181.125.000.301.000	Ag	24	-0.04	30	46	51	27	58	M24 × 2	17.8
181.127.000.301.000	Ag	28	-0.04	36	46	52	32	62	M32 × 2	25
181.128.000.301.000	Ag	30	-0.04	38	46	52	32	62	M32 × 2	25

SPECIFICATIONS

- For all round ODU SPRINGTAC® sockets
- For tightening torque see page 59
- Suitable for screwing to power busbars, backplanes and contact blocks
- Cables with lugs can be easily connected.
- Cables can be soldered into the solder hole.

Other variants, dimensions and finishes available on request.

¹ Tolerance diameter A

ODU CONTACT PIN



For all ODU SPRINGTAC® sockets

CRIMP TERMINATION



Ag Au

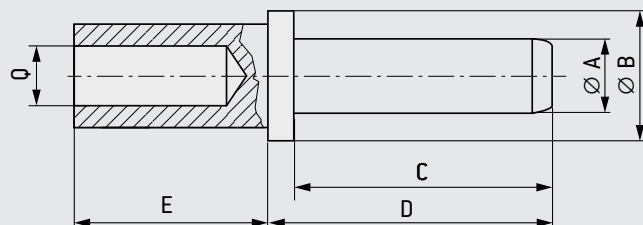

Part number	Surface	Dimensions						
		Ø A mm	x ¹ mm	Ø B mm	C mm	D mm	E mm	Q mm ²
180.361.000.307.000	Ag	0.765	-0.015	1.57	7	16.9	4.9	0.38
180.362.000.307.000	Ag	1.02	-0.03	2.1	7	16.9	4.9	0.5
181.606.000.301.000	Ag	1.5	-0.03	4	10	11.5	6.5	1.5
181.606.000.307.000	Au							
181.607.000.301.000	Ag	2	-0.03	4	10	11.5	6.5	2.5
181.607.000.307.000	Au							
181.609.000.301.000	Ag	2.5	-0.03	6	10	11.5	6.5	2.5
181.609.000.307.000	Au							
181.610.000.301.000	Ag	3	-0.03	7	14	16	6.5	4
181.610.000.307.000	Au							
181.611.000.301.000	Ag	4	-0.03	8	14	16	12.5	6
181.611.000.307.000	Au							
181.612.000.301.000	Ag	5	-0.03	9	14	16	17.5	10
181.613.000.301.000	Ag	6	-0.03	11	23	26	22.5	16
181.713.000.301.000	Ag	6	-0.03	11	23	26	22.5	25
181.615.000.301.000	Ag	8	-0.03	14	23	26	22.5	25
181.715.000.301.000	Ag	8	-0.03	14	23	26	22.5	35
181.617.000.301.000	Ag	10	-0.04	16	23	26	22.5	35
181.717.000.301.000	Ag	10	-0.04	16	23	26	22.5	50
181.619.000.301.000	Ag	12	-0.04	18	34	38	28	50
181.621.000.301.000	Ag	16	-0.04	23	34	38	28	95

Other variants, dimensions and finishes available on request.

¹ Tolerance diameter A

SPECIFICATIONS

- For all round ODU SPRINGTAC® sockets
- Easy and quick termination by crimping (crimp information starting on page 54)
- Suitable for connecting harmonized cables
- Part number crimping tool see table on page 56

EXTERNALLY FLEXED CONTACT PIN



Contact with springwire technology

SOLDER/SCREW TERMINATION



Ag

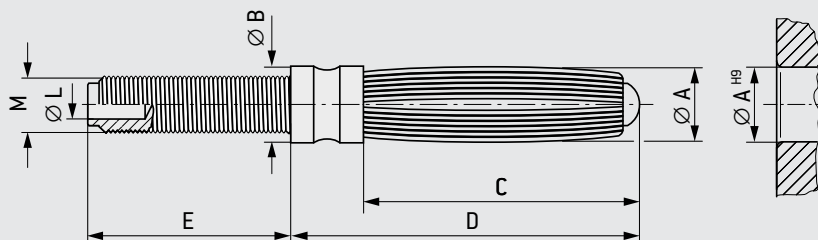

Part number	Dimensions							Mechanical data ¹		Electrical data ¹		
	Ø A mm	Ø B mm	C mm	D mm	E mm	M Thread	Ø L ¹ mm	Mating force N	Demating force N	Nominal current A	Max. continuous current A	Contact resistance µΩ
150.001.100.201.000	1.5	3	6	11.2	8	M2.3	1.25	2	2	10	15	800
150.002.100.201.000	2	3	9	14.1	9	M2.3	1.25	4	3	15	18	675
150.005.100.201.000	3	3.5	13	18.5	11.5	M2.6	1.4	6	5	25	35	600
150.006.100.201.000	4	5	20.5	26	13	M3	1.8	10	8	36	50	525
150.007.100.201.000	5	6	20.5	26	15	M4	2.4	15	12	45	65	475
150.008.100.201.000	6	7	22	29.1	17	M5	3.2	19	14	55	80	425
150.009.100.201.000	7	8	22	29	17	M6	4	21	16	65	100	375
150.010.100.201.000	8	9	33	41.5	19	M6	4	24	18	78	130	325
150.011.100.201.000	9	10.5	33	41.5	20.5	M8	5.2	28	22	90	150	275
150.012.100.201.000	10	11.5	33	41.5	22	M8	5.2	32	25	104	175	250
150.013.100.201.000	12	14	33	41.5	25	M10	6.5	38	30	135	215	200
150.015.100.201.000	16	18	45	59	32	M14 × 1.5	9.5	50	40	175	270	165

Other variants, dimensions and finishes available on request.

¹ See "Technical Information" starting on page 63

SPECIFICATIONS

- For tightening torque see page 59
- Cables with lugs can be easily connected.
- Cables can be soldered into the solder hole.



ODU ELECTRICAL CONTACTS

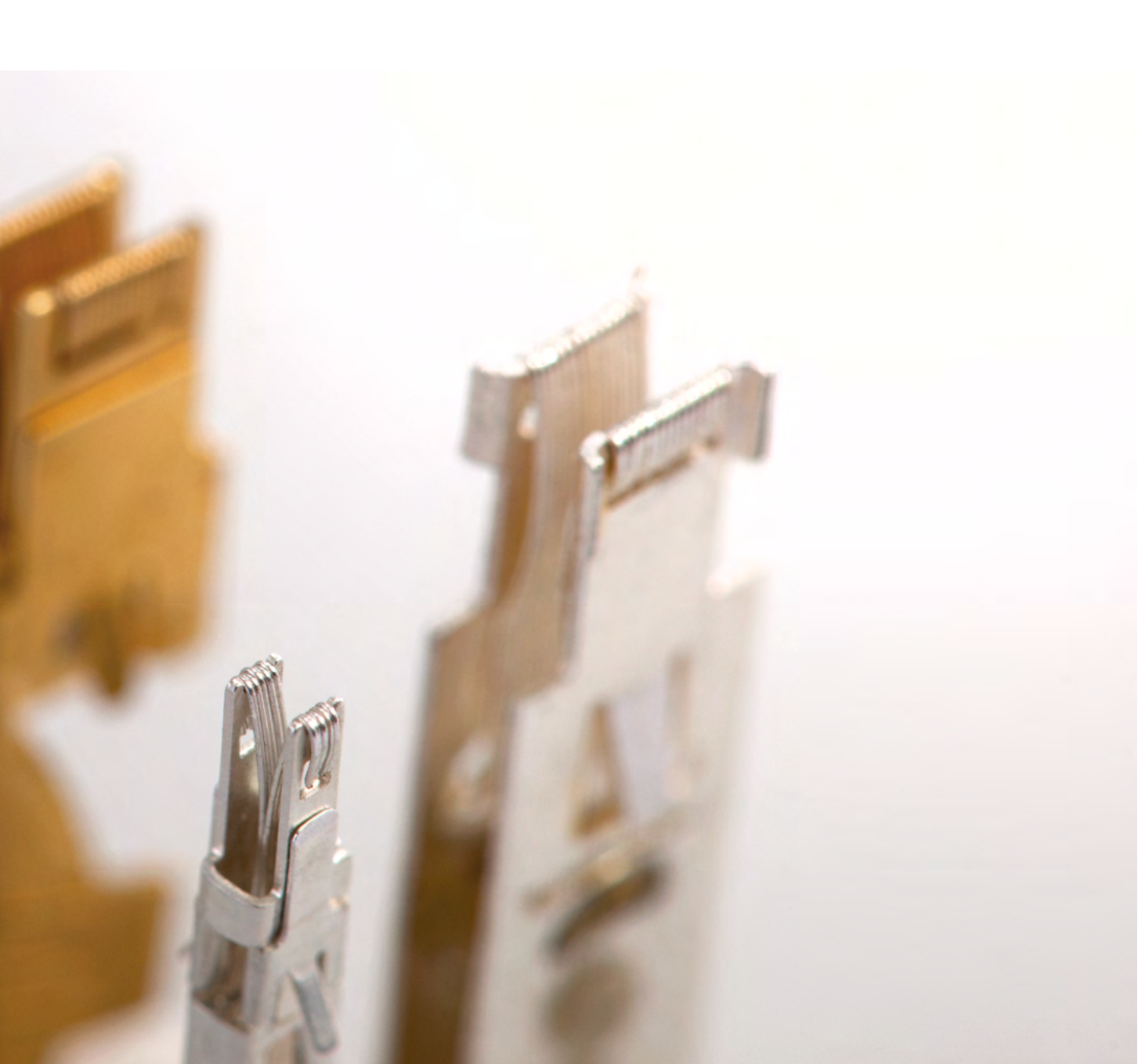

ODU SPRINGTAC® FLATSOCKETS

- ODU SPRINGTAC® Flatsocket
for 2-wire measurement, with crimp termination [34](#)
- ODU SPRINGTAC® Flatsocket
for 2-wire measurement, QCH (quick-change head) [35](#)
- ODU SPRINGTAC® Flatsocket
for 4-wire measurement (Kelvin measurement), with solder termination [36](#)

ODU SPRINGTAC® FLATSOCKET

For 2-wire measurement
 Flatsocket with springwire technology



CRIMP TERMINATION

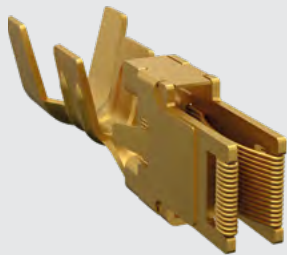

Ag Au

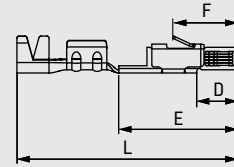
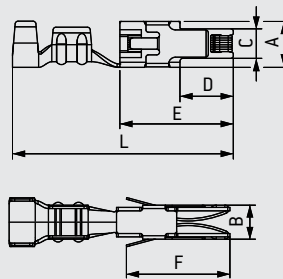

Illustration applies to part number
 190.222 ... 000

Part number	Surface	For pin	Q ¹ mm ²	Dimensions							Mechanical data ¹		Electrical data ¹		
				A mm	B mm	C mm	D mm	E mm	F mm	L mm	Mating force N	Demating force N	Nominal current A	Max. continuous current A	Contact resistance mΩ
190.222.700.201.000	Ag	0.64 × 0.64	0.25 – 0.5	1.8	1.85	1.4	2	5.6	4	13.7	1.5 ± 1	1 ± 0.6	7	9	7.5
190.222.700.207.000	Au														
190.218.100.201.000	Ag	1.6 × 0.6	0.5 – 1	2.6	2.2	1.35	4.3	10	8.3	19.5	2 ± 1.5	1.5 ± 1	13	18	2.7
190.218.700.207.000	Au	1.6 × 0.8													
190.214.100.201.000	Ag	2.8 × 0.8	1 – 1.5	4	3	2.6	4.7	10	9.2	19.5	4 ± 2	3 ± 2	16	22	2
190.214.700.207.000	Au														
190.215.100.201.000	Ag	4.8 × 0.8	1.5 – 2.5	6.8	3	4.8	6	11	10.5	20.5	6 ± 2	5 ± 2	22	30	1.3
190.215.700.207.000	Au	6.3 × 0.8													
190.216.100.201.000	Ag	4.8 × 0.8	4	6.8	3	4.8	6	11	10.5	24.5	6 ± 2	5 ± 2	27	36	1.3
190.216.700.207.000	Au	6.3 × 0.8													

Other variants, dimensions and finishes available on request.

¹ See "Technical Information" starting on page [63](#)

SPECIFICATIONS

- High current-carrying capacity
- Ideal for test adapters
- > 50,000 mating cycles
- Part number crimping tool see table on page [56](#)
- Chamber dimensions see page [70](#)

ODU SPRINGTAC® FLATSOCKET

For 2-wire measurement
 Flatsocket with springwire technology

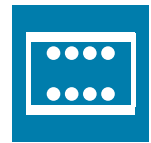

ODU QCH (QUICK-CHANGE HEAD)

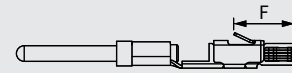
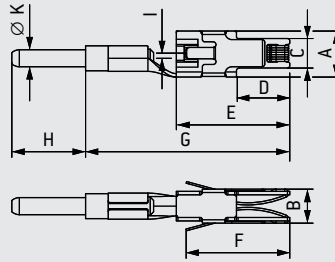
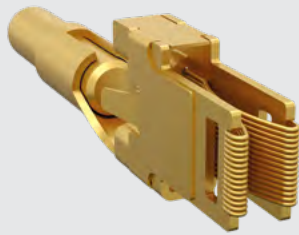

Illustration applies to part number
 190.242 000

Ag Au

Part number	Surface	For pin	Dimensions										Mechanical data ¹		Electrical data ¹			
			A	B	C	D	E	F	G	H	I	Ø K	Mating force	Demating force	Nominal current	Max. continuous current	Contact resistance	
			mm	mm	mm	mm	mm	mm	mm	mm	mm	mm	mm	N	N	A	A	mΩ
190.242.700.201.000	Ag	0.64 × 0.64	1.8	1.85	1.4	2	5.6	4	11.5	6.5	0 ± 0.15	1.02	1.5 ± 1	1 ± 0.6	7	9	7.5	
190.242.700.207.000	Au																	
190.238.100.201.000	Ag	1.6 × 0.6	2.6	2.2	1.35	4.3	10	8.3	18	6.5	0 ± 0.3	1.02	2 ± 1.5	1.5 ± 1	11	16	2.7	
190.238.700.207.000	Au																	1.6 × 0.8
190.234.100.201.000	Ag	2.8 × 0.8	4	3	2.6	4.7	10	9.2	18	6.5	1 ± 0.5	1.5	4 ± 2	3 ± 2	16	22	2	
190.234.700.207.000	Au																	
190.235.100.201.000	Ag	4.8 × 0.8	6.8	3	4.8	6	11	10.5	20.5	6.5	1 ± 0.5	3	6 ± 2	5 ± 2	27	36	1.3	
190.235.700.207.000	Au																	6.3 × 0.8

Other variants, dimensions and finishes available on request.

¹ See "Technical Information" starting on page 63

SPECIFICATIONS

- With circular termination pin, suitable for all ODU sockets
- Ideal for test adapters and replacement inserts
- > 50,000 mating cycles
- Chamber dimensions see page 70

ODU SPRINGTAC® FLATSOCKET

For 4-wire measurement (Kelvin measurement)
Flatsocket with springwire technology



SOLDER TERMINATION

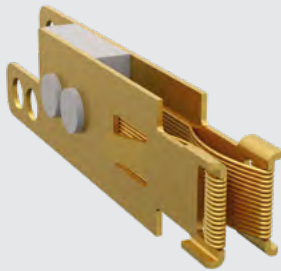

Ag Au

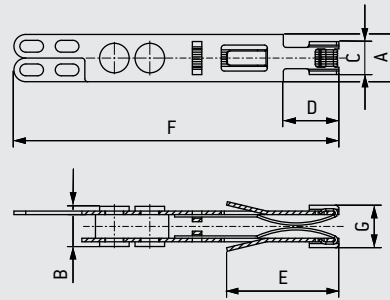

Part number	Surface	Size	For pin	Q ¹ mm ²	Dimensions							Mechanical data ¹		Electrical data ¹		
					A	B	C	D	E	F	G	Mating force N	Demating force N	Nominal current A	Max. continuous current A	Contact resistance mΩ
190.224.100.201.000	Ag	1	2.8 × 0.8	1.5	4	3.4	2.6	4.7	9.5	27.5	3.6	4 ± 2	3 ± 2	7	12	2
190.224.700.207.000	Au															
190.225.100.201.000	Ag	2	4.8 × 0.8	2.5	6.8	3.4	4.8	6	10.5	27.5	3.6	6 ± 2	5 ± 2	12	17	2
190.225.700.207.000	Au															

Other variants, dimensions and finishes available on request.

¹ See "Technical Information" starting on page [63](#)

SPECIFICATIONS

- For precise measurement of low electrical resistance.
- Mutually insulated termination for current and voltage path
- Ideal for test adapters
- > 50,000 mating cycles
- Chamber dimensions see page [70](#)

FOR YOUR NOTES

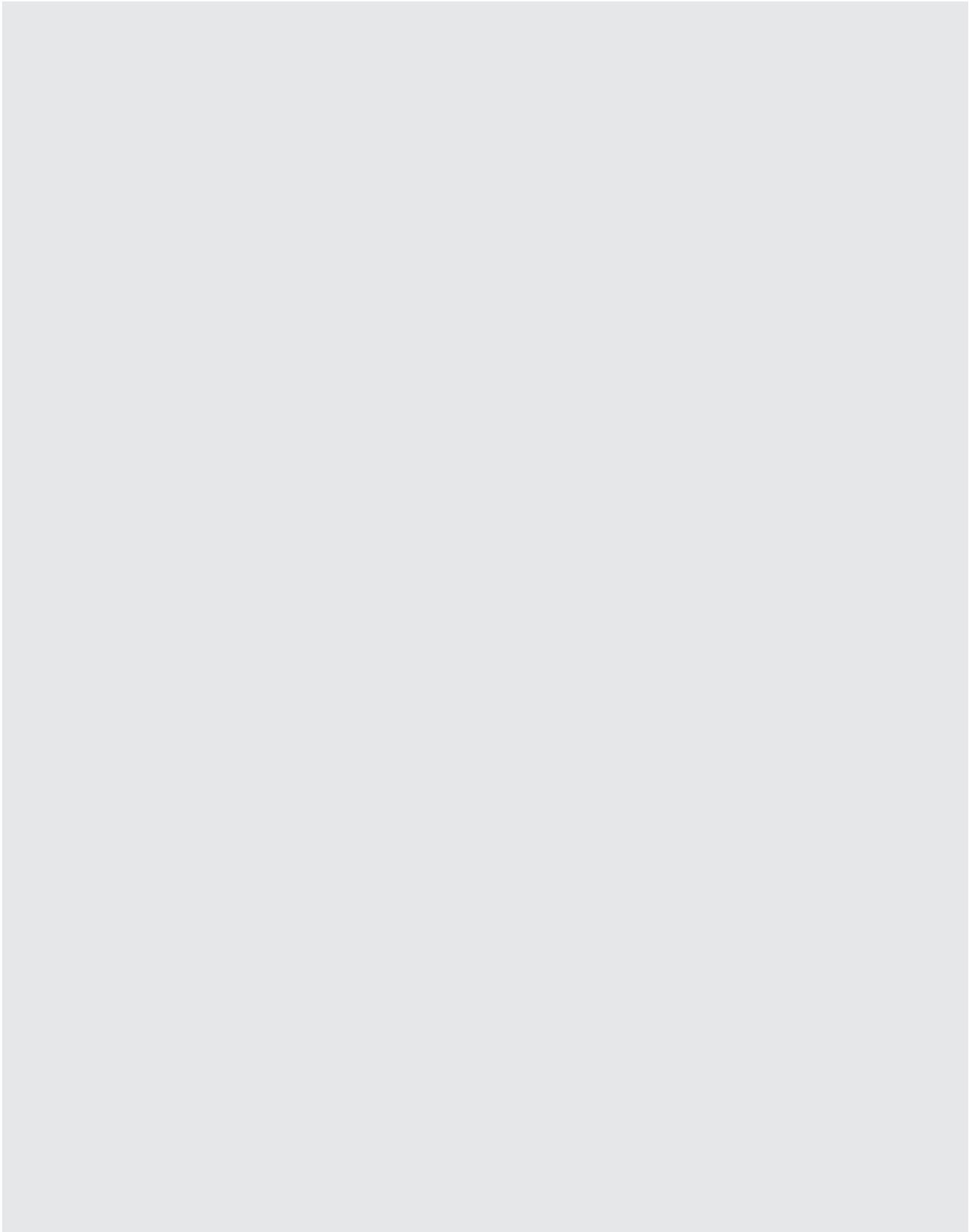
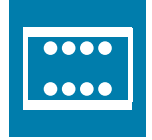



ODU ELECTRICAL CONTACTS



ODU LAMTAC®

ODU LAMTAC® socket with solder / screw termination	40
ODU LAMTAC® socket with crimp termination	41
ODU LAMTAC® socket with outer thread	42
ODU contact pin with solder / screw termination	44
ODU contact pin with crimp termination	45

ODU LAMTAC® SOCKET

Contact with lamella technology



SOLDER/SCREW TERMINATION



Ag Au

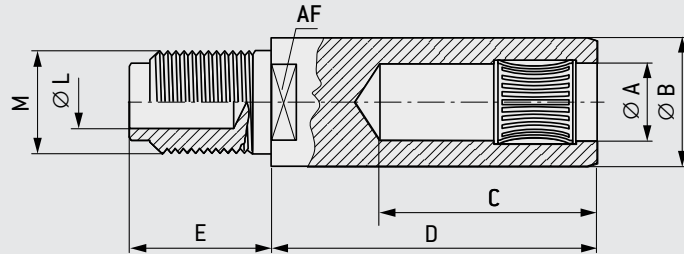

Part number	Surface	Dimensions								Mechanical data ¹		Electrical data ¹				
		Ø A	Ø B	C	D	SW	E	M	Ø L ¹	Q ¹	Mating force	Demating force	Nominal current	Max. continuous current	Surge current	Contact resistance
		mm	mm	mm	mm	mm	mm	Thread	mm	mm ²	N	N	A	A	kA	µΩ
178.106.100.201.000	Ag	1.5	4	10.5	15.5	–	12.5	M2.6	1.25	1.5	4	3	28	49	2	450
178.106.700.207.000	Au															
178.107.100.201.000	Ag	2	4	10.5	15.5	–	12.5	M3	1.8	2.5	6	5	36	62	2.5	400
178.107.700.207.000	Au															
178.110.100.201.000	Ag	3	7	15	22.5	5	15	M4	2.3	4	8	8	50	88	5	350
178.110.700.207.000	Au															
178.111.100.201.000	Ag	4	8	15	22.5	6	19	M5	3	6	10	10	65	115	8	300
178.111.700.207.000	Au															
178.112.100.201.000	Ag	5	9	18.5	22.5	7	19	M5	3	10	15	13	90	155	12	250
178.113.100.201.000	Ag	6	11	24	33.5	8	22	M6	3.6	16	20	15	115	205	19	170
178.213.100.201.000	Ag	6	11	24	33.5	8	26	M8	4.8	25	20	15	145	260	19	170
178.115.100.201.000	Ag	8	14	24	33.5	11	26	M8	4.8	25	25	20	150	275	26	120
178.215.100.201.000	Ag	8	14	24	33.5	11	30	M10	6.2	35	25	20	185	330	26	120
178.117.100.201.000	Ag	10	16	24	33.5	12	30	M10	6.2	35	30	25	190	340	27	100
178.217.100.201.000	Ag	10	16	24	33.5	12	34	M12 × 1.5	7.6	50	30	25	230	410	27	100
178.119.100.201.000	Ag	12	18	36	47	14	34	M12 × 1.5	7.6	50	30	25	235	420	35	80
178.121.100.201.000	Ag	16	23	36	47	19	42	M16 × 1.5	11.5	95	35	30	370	650	48	70
178.123.100.201.000	Ag	20	27	48	66	22	50	M20 × 2	14.5	150	40	35	490	870	56	50
178.125.100.201.000	Ag	24	32	48	66	27	58	M24 × 2	17.8	240	45	40	670	1,235	62	40
178.127.100.201.000	Ag	28	36	48	66	32	62	M32 × 2	25	400	50	45	885	1,610	68	30
178.128.100.201.000	Ag	30	38	48	66	32	62	M32 × 2	25	500	55	50	990	1,790	70	25

Other variants, dimensions and finishes available on request.

¹ See "Technical Information" starting on page 63

SPECIFICATIONS

- Suitable for contact pins (page 44 and 45)
- For tightening torque see page 59
- Suitable for screwing to power busbars, backplanes and contact blocks
- Cables with lugs can be easily connected.
- Cables can be soldered into the solder hole.

ODU LAMTAC® SOCKET



Contact with lamella technology

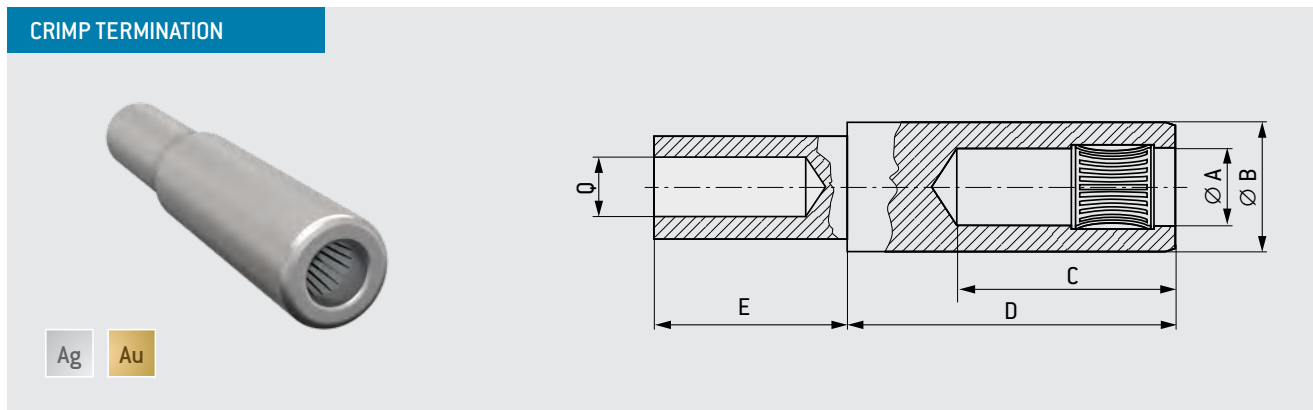

Part number	Surface	Dimensions						Mechanical data ¹		Electrical data ¹			
		Ø A mm	Ø B mm	C mm	D mm	E mm	Q ¹ mm ²	Mating force N	Demating force N	Nominal current A	Max. continuous current A	Surge current kA	Contact resistance µΩ
178.606.100.201.000	Ag	1.5	4	10.5	15.5	6.5	1.5	4	3	28	49	2	450
178.606.700.207.000	Au												
178.607.100.201.000	Ag	2	4	10.5	15.5	6.5	2.5	6	5	36	62	2.5	400
178.607.700.207.000	Au												
178.610.100.201.000	Ag	3	7	15	22.5	6.5	4	8	8	50	88	5	350
178.610.700.207.000	Au												
178.611.100.201.000	Ag	4	8	15	22.5	12.5	6	10	10	65	115	8	300
178.611.700.207.000	Au												
178.612.100.201.000	Ag	5	9	18.5	22.5	17.5	10	15	13	90	155	12	250
178.613.100.201.000	Ag	6	11	24	33.5	22.5	16	20	15	115	205	19	170
178.713.100.201.000	Ag	6	11	24	33.5	22.5	25	20	15	145	260	19	170
178.615.100.201.000	Ag	8	14	24	33.5	22.5	25	25	20	150	275	26	120
178.715.100.201.000	Ag	8	14	24	33.5	22.5	35	25	20	185	330	26	120
178.617.100.201.000	Ag	10	16	24	33.5	22.5	35	30	25	190	340	27	100
178.717.100.201.000	Ag	10	16	24	33.5	22.5	50	30	25	230	410	27	100
178.619.100.201.000	Ag	12	18	36	47	28	50	30	25	235	420	35	80
178.621.100.201.000	Ag	16	23	36	47	28	95	35	30	370	650	48	70

Other variants, dimensions and finishes available on request.

¹ See "Technical Information" starting on page 63

SPECIFICATIONS

- Suitable for contact pins (page 44 and 45)
- Easy and quick termination by crimping (crimp information see page 54)
- Suitable for connecting harmonized cables
- Part number crimping tool see table on page 56

ODU LAMTAC® SOCKET



Contact with lamella technology

OUTSIDE THREAD



Ag

Au

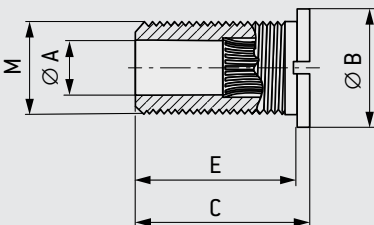

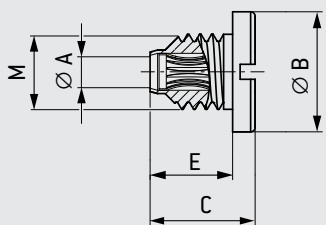

Illustration applies to part number
178.34 000

Part number	Surface	Dimensions					Mechanical data ¹			Electrical data ¹			
		Ø A mm	Ø B mm	C mm	E mm	M Thread	Mating force N	Demating force N	Tightening torque Nm	Nominal current A	Max. continuous current A	Surge current kA	Contact resistance µΩ
178.346.100.201.000	Ag	1.5	7	7	5.5	M4	4	3	0.5	28	49	2	350
178.346.700.207.000	Au												
178.347.100.201.000	Ag	2	8	7	5.5	M5	6	5	0.5	36	62	2.5	300
178.347.700.207.000	Au												
178.350.100.201.000	Ag	3	10	12	10	M7 × 0.5	8	8	1.2	50	88	5	190
178.350.700.207.000	Au												
178.351.100.201.000	Ag	4	11	13	10	M8 × 1	10	10	1.2	65	115	8	170
178.351.700.207.000	Au												
178.352.100.201.000	Ag	5	13	13	10	M10	15	13	3	90	155	12	150
178.355.100.201.000	Ag	6	16	19	16	M12 × 1.5	20	15	6	145	260	19	110
178.356.100.201.000	Ag	8	18	19	16	M14 × 1.5	25	20	6	185	330	26	80
178.358.100.201.000	Ag	10	22	19	16	M18 × 1.5	30	25	10	230	410	27	60

Other variants, dimensions and finishes available on request.

¹ See "Technical Information" starting on page [63](#)

SPECIFICATIONS

- Suitable for contact pins (page [44](#) and [45](#))
- Suitable for screwing to power busbars, backplanes and contact blocks

ODU LAMTAC® SOCKET

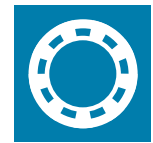

Contact with lamella technology

OUTSIDE THREAD

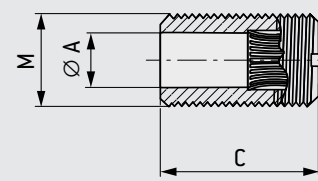
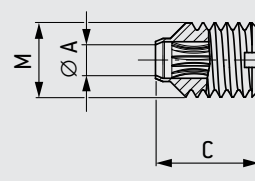
Ag Au

Illustration applies to part number 178.30 000

Part number	Surface	Dimensions			Mechanical data ¹			Electrical data ¹			
		Ø A mm	C mm	M Thread	Mating force N	Demating force N	Tighten- ing torque Nm	Nominal current A	Max. continuous current A	Surge current kA	Contact resistance µΩ
178.306.100.201.000	Ag	1.5	7	M4	4	3	0.5	28	49	2	350
178.306.700.207.000	Au										
178.307.100.201.000	Ag	2	7	M5	6	5	0.5	36	62	2.5	300
178.307.700.207.000	Au										
178.310.100.201.000	Ag	3	12	M7 × 0.5	8	8	1.2	50	88	5	190
178.310.700.207.000	Au										
178.311.100.201.000	Ag	4	13	M8 × 1	10	10	1.2	65	115	8	170
78.311.700.207.000	Au										
178.312.100.201.000	Ag	5	13	M10	15	13	3	90	155	12	150
178.314.100.201.000	Ag	6	19	M12 × 1.5	20	15	6	145	260	19	110
178.315.100.201.000	Ag	8	19	M14 × 1.5	25	20	6	185	330	26	80
178.318.100.201.000	Ag	10	19	M18 × 1.5	30	25	10	230	410	27	60

Other variants, dimensions and finishes available on request.

¹ See "Technical Information" starting on page [63](#)

SPECIFICATIONS

- Suitable for contact pins (page [44](#) and [45](#))
- Suitable for screwing to power busbars, backplanes and contact blocks

ODU CONTACT PIN

For all ODU LAMTAC® sockets



SOLDER/SCREW TERMINATION



Ag Au

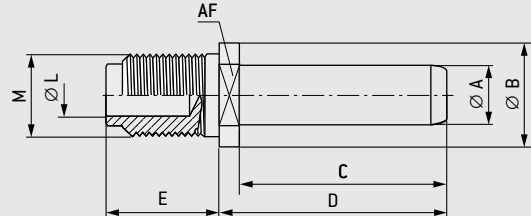

Part number	Surface	Dimensions								
		Ø A mm	x ¹ mm	Ø B mm	C mm	D mm	SW mm	E mm	Inv. Thread	Ø L mm
181.106.000.301.000	Ag	1.5	-0.03	4	10	11.5	3	10	M2.6	1.25
181.106.000.307.000	Au									
181.107.000.301.000	Ag	2	-0.03	5	10	11.5	4	12.5	M3	1.8
181.107.000.307.000	Au									
181.110.000.301.000	Ag	3	-0.03	6	14	15.5	5	15	M4	2.3
181.110.000.307.000	Au									
181.111.000.301.000	Ag	4	-0.03	7	14	16	6	19	M5	3
181.111.000.307.000	Au									
181.212.000.301.000	Ag	5	-0.03	7	17.5	19.5	6	19	M5	3
181.113.000.301.000	Ag	6	-0.03	8	23	26	7	22	M6	3.6
181.213.000.301.000	Ag	6	-0.03	11	23	26	8	22	M8	4.8
181.115.000.301.000	Ag	8	-0.03	11	23	26	9	26	M8	4.8
181.215.000.301.000	Ag	8	-0.03	14	23	26	11	26	M10	6.2
181.117.000.301.000	Ag	10	-0.04	16	23	26	12	30	M10	6.2
181.217.000.301.000	Ag	10	-0.04	16	23	26	12	30	M12 × 1.5	7.6
181.119.000.301.000	Ag	12	-0.04	16	34	38	14	34	M12 × 1.5	7.6
181.121.000.301.000	Ag	16	-0.04	20	34	38	17	42	M16 × 1.5	11.5
181.123.000.301.000	Ag	20	-0.04	25	46	51	22	50	M20 × 2	14.5
181.125.000.301.000	Ag	24	-0.04	30	46	51	27	58	M24 × 2	17.8
181.127.000.301.000	Ag	28	-0.04	36	46	52	32	62	M32 × 2	25
181.128.000.301.000	Ag	30	-0.04	38	46	52	32	62	M32 × 2	25

SPECIFICATIONS

- Suitable for all round ODU LAMTAC® sockets
- For tightening torque see page 59
- Suitable for screwing to power busbars, backplanes and contact blocks
- Cables with lugs can be easily connected.
- Cables can be soldered into the solder hole.

Other variants, dimensions and finishes available on request.

¹ Tolerance diameter A.

ODU CONTACT PIN

For all ODU LAMTAC® sockets

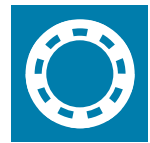

CRIMP TERMINATION



Ag Au

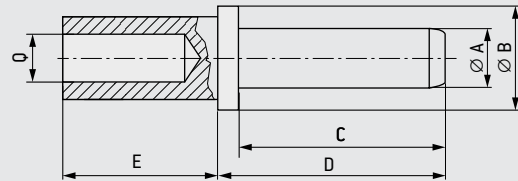

Part number	Surface	Dimensions						
		Ø A mm	x ¹ mm	Ø B mm	C mm	D mm	E mm	Q mm ²
181.606.000.301.000	Ag	1.5	-0.03	4	10	11.5	6.5	1.5
181.606.000.307.000	Au							
181.607.000.301.000	Ag	2	-0.03	4	10	11.5	6.5	2.5
181.607.000.307.000	Au							
181.610.000.301.000	Ag	3	-0.03	7	14	16	6.5	4
181.610.000.307.000	Au							
181.611.000.301.000	Ag	4	-0.03	8	14	16	12.5	6
181.611.000.307.000	Au							
181.712.000.301.000	Ag	5	-0.03	9	17.5	19.5	17.5	10
181.613.000.301.000	Ag	6	-0.03	11	23	26	22.5	16
181.713.000.301.000	Ag	6	-0.03	11	23	26	22.5	25
181.615.000.301.000	Ag	8	-0.03	14	23	26	22.5	25
181.715.000.301.000	Ag	8	-0.03	14	23	26	22.5	35
181.617.000.301.000	Ag	10	-0.04	16	23	26	22.5	35
181.717.000.301.000	Ag	10	-0.04	16	23	26	22.5	50
181.619.000.301.000	Ag	12	-0.04	18	34	38	28	50
181.621.000.301.000	Ag	16	-0.04	23	34	38	28	95

Other variants, dimensions and finishes available on request.

¹ Tolerance diameter A

SPECIFICATIONS

- Suitable for all round ODU LAMTAC® sockets
- Easy and quick termination by crimping (crimp information see page 54)
- Suitable for connecting harmonized cables
- Part number crimping tool see table on page 56



ODU ELECTRICAL CONTACTS

[Table of contents](#)

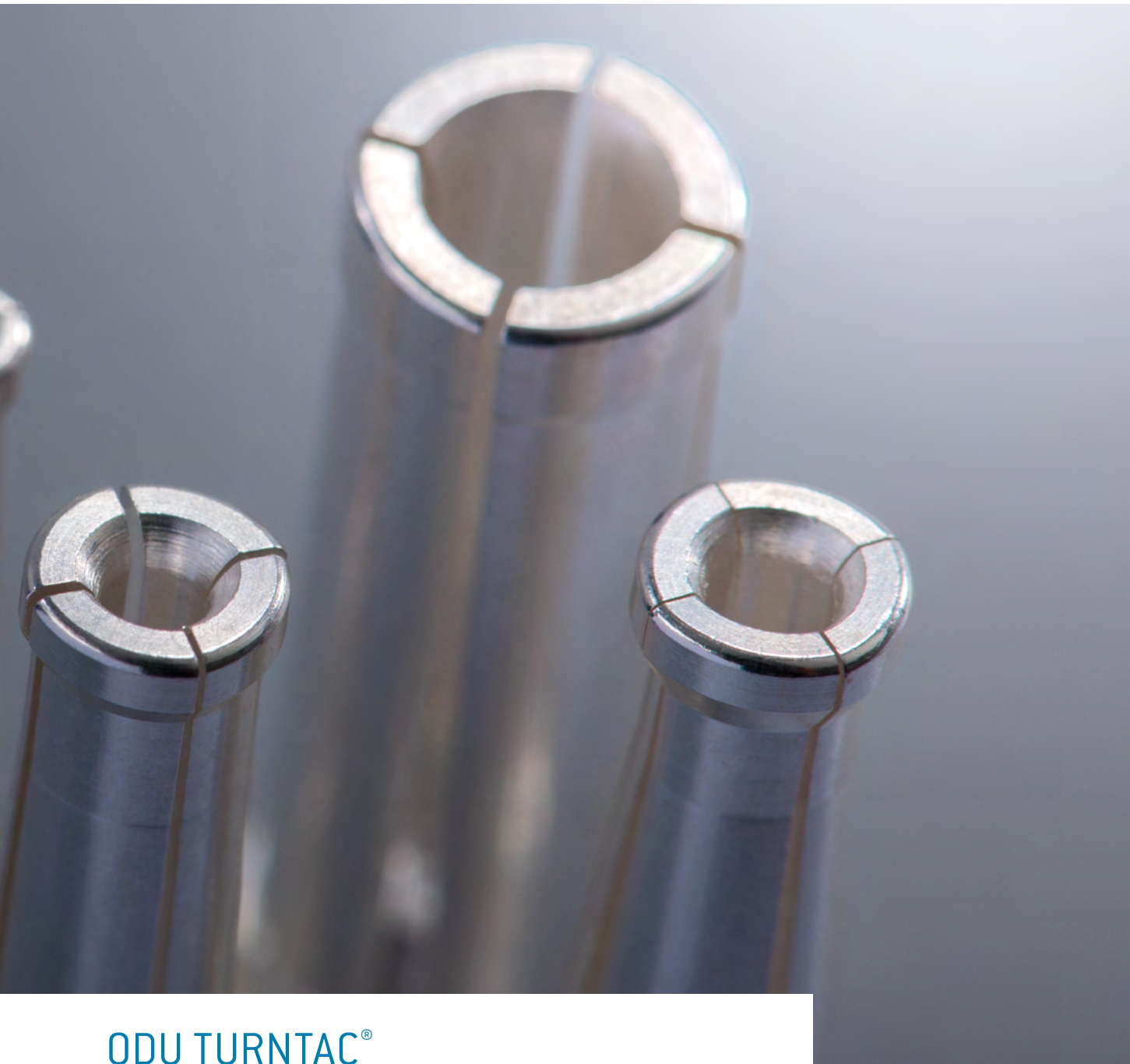

ODU TURNTAC®

ODU TURNTAC® socket with solder / screw termination	48
ODU TURNTAC® socket with crimp termination	49
ODU contact pin with solder / screw termination	50
ODU contact pin with crimp termination	51

ODU TURNTAC® SOCKET



Contacts in slotted version

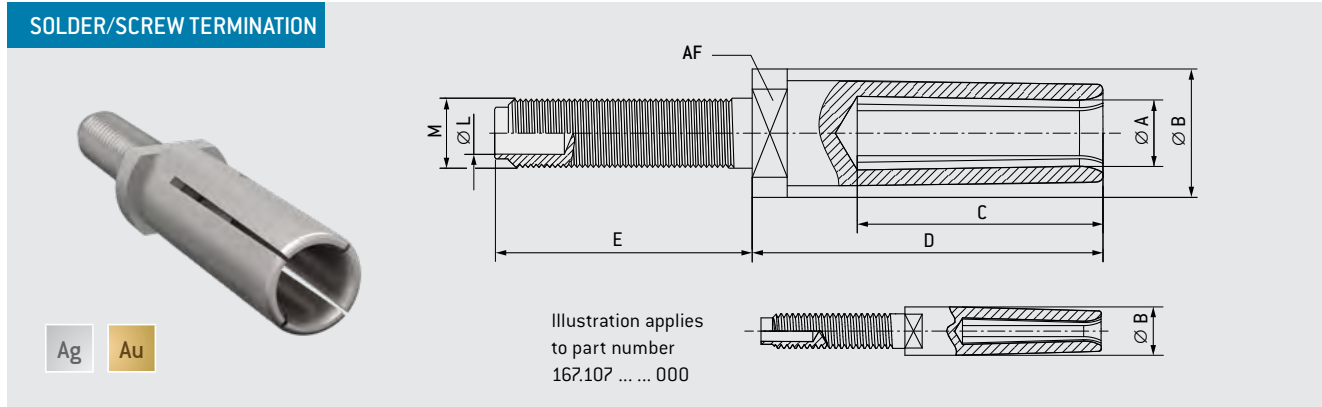

Part number	Surface	Dimensions									Mechanical data ¹		Electrical data ¹		
		Ø A	Ø B	C	D	SW	E	M	Ø L ¹	Q ¹	Mating force	Demating force	Nominal current	Max. continuous current	Contact resistance
		mm	mm	mm	mm	mm	mm	Thread	mm	mm ²	N	N	A	A	µΩ
167.106.000.301.000	Ag	1.5	4	12.5	17.5	3	10	M2.6	1.25	1.5	3	1.5	25	39	600
167.106.000.307.000	Au														
167.107.000.301.000	Ag	2	4.2	12	17	3	12.5	M3	1.8	2.5	4	2	34	53	500
167.107.000.307.000	Au														
167.110.000.301.000	Ag	3	7	15	19.5	5	15	M4	2.3	4	5	2.5	50	75	400
167.110.000.307.000	Au														
167.111.000.301.000	Ag	4	8	15	21	6	19	M5	3	6	6	3	55	90	300
167.111.000.307.000	Au														
167.112.000.301.000	Ag	5	9	17.5	25	7	19	M5	3	10	7	3.5	75	120	200
167.113.000.301.000	Ag	6	11	21	30	8	22	M6	3.6	16	8	4	100	150	175
167.115.000.301.000	Ag	8	14	25	35	11	26	M8	4.8	25	10	5	125	190	150
167.117.000.301.000	Ag	10	16	25	35	12	30	M10	6.2	35	12	6	165	250	125

Other variants, dimensions and finishes available on request.

¹ See "Technical Information" starting on page 63

SPECIFICATIONS

- Suitable for contact pins (page 50 and 51)
- For tightening torque see page 59
- Suitable for screwing to power busbars, backplanes and contact blocks
- Cables with lugs can be easily connected.
- Cables can be soldered into the solder hole.
- Chamber dimensions see page 49

ODU TURNTAC® SOCKET



Contacts in slotted version

CRIMP TERMINATION

Ag Au

Illustration applies to part number 167.607 ... 000

Part number	Surface	Dimensions						Mechanical data ¹		Electrical data ¹		
		Ø A mm	Ø B mm	C mm	D mm	E mm	Q ¹ mm ²	Mating force N	Demating force N	Nominal current A	Max. continuous current A	Contact resistance µΩ
167.606.000.301.000	Ag	1.5	4	12.5	17.5	6.5	1.5	3	1.5	25	39	600
167.606.000.307.000	Au											
167.607.000.301.000	Ag	2	4.2	12	17	6.5	2.5	4	2	34	53	500
167.607.000.307.000	Au											
167.610.000.301.000	Ag	3	7	15	19.5	6.5	4	5	2.5	50	75	400
167.610.000.307.000	Au											
167.611.000.301.000	Ag	4	8	15	21	12.5	6	6	3	55	90	300
167.611.000.307.000	Au											
167.612.000.301.000	Ag	5	9	17.5	25	17.5	10	7	3.5	75	120	200

Other variants, dimensions and finishes available on request.
¹ See "Technical Information" starting on page 63

SPECIFICATIONS

- Suitable for contact pins (page 50 and 51)
- Easy and quick termination by crimping (crimp information starting on page 54)
- Suitable for connecting harmonized cables
- Part number crimping tool see table on page 57

Chamber dimensions		
Ø A mm	Ø X mm	Ø Z mm
1.5	3.9 ± 0.03	1.8 + 0.1
2	4.3 ± 0.03	2.3 + 0.1
3	6 ± 0.05	3.3 + 0.1
4	6.7 ± 0.1	4.3 + 0.1
5	8 ± 0.1	5.3 + 0.1
6	9.3 ± 0.1	6.3 + 0.1
8	12.3 ± 0.1	8.3 + 0.1
10	14.3 ± 0.1	10.3 + 0.1

Chamber dimensions for solder/screw termination and crimp termination

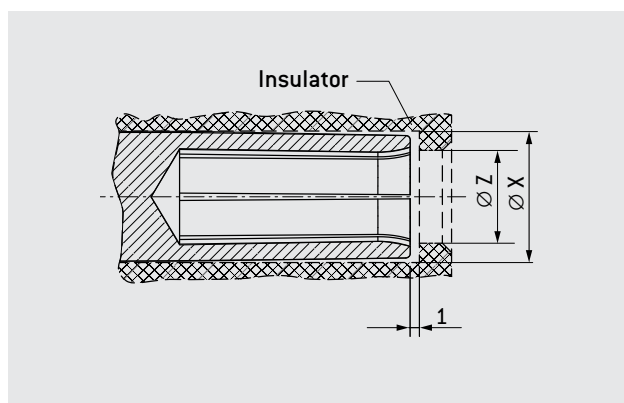

ODU CONTACT PIN



For all ODU TURNTAC® sockets.

SOLDER/SCREW TERMINATION



Ag

Au

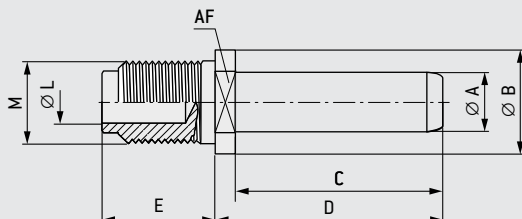

Part number	Surface	Dimensions								
		Ø A mm	x ¹ mm	Ø B mm	C mm	D mm	AF mm	E mm	M Thread	Ø L mm
181.106.000.301.000	Ag	1.5	-0.03	4	10	11.5	3	10	M2.6	1.25
181.106.000.307.000	Au	1.5	-0.03	4	10	11.5	3	10	M2.6	1.25
181.107.000.301.000	Ag	2	-0.03	5	10	11.5	4	12.5	M3	1.8
181.107.000.307.000	Au	2	-0.03	5	10	11.5	4	12.5	M3	1.8
181.110.000.301.000	Ag	3	-0.03	6	14	15.5	5	15	M4	2.3
181.110.000.307.000	Au	3	-0.03	6	14	15.5	5	15	M4	2.3
181.111.000.301.000	Ag	4	-0.03	7	14	16	6	19	M5	3
181.111.000.307.000	Au	4	-0.03	7	14	16	6	19	M5	3
181.212.000.301.000	Ag	5	-0.03	7	17.5	19.5	6	19	M5	3
181.113.000.301.000	Ag	6	-0.03	8	23	26	7	22	M6	3.6
181.213.000.301.000	Ag	6	-0.03	11	23	26	8	22	M8	4.8
181.115.000.301.000	Ag	8	-0.03	11	23	26	9	26	M8	4.8
181.215.000.301.000	Ag	8	-0.03	14	23	26	11	26	M10	6.2
181.117.000.301.000	Ag	10	-0.04	16	23	26	12	30	M10	6.2
181.217.000.301.000	Ag	10	-0.04	16	23	26	12	30	M12 × 1.5	7.6

Other variants, dimensions and finishes available on request.

¹ Tolerance diameter A

SPECIFICATIONS

- Suitable for all round ODU TURNTAC® sockets
- For tightening torque see page 59
- Suitable for screwing to power busbars, backplanes and contact blocks
- Cables with lugs can be easily connected.
- Cables can be soldered into the solder hole.

ODU CONTACT PIN

For all ODU TURNTAC® sockets



CRIMP TERMINATION

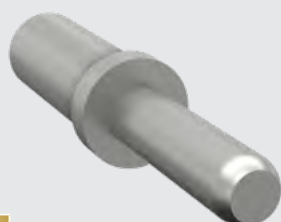

Ag

Au

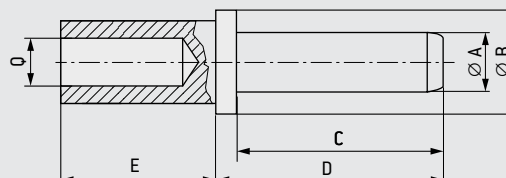

Part number	Surface	Dimensions						
		Ø A mm	x ¹ mm	Ø B mm	C mm	D mm	E mm	Ø mm ²
181.606.000.301.000	Ag	1.5	-0.03	4	10	11.5	6.5	1.5
181.606.000.307.000	Au	1.5	-0.03	4	10	11.5	6.5	1.5
181.607.000.301.000	Ag	2	-0.03	4	10	11.5	6.5	2.5
181.607.000.307.000	Au	2	-0.03	4	10	11.5	6.5	2.5
181.610.000.301.000	Ag	3	-0.03	7	14	16	6.5	4
181.610.000.307.000	Au	3	-0.03	7	14	16	6.5	4
181.611.000.301.000	Ag	4	-0.03	8	14	16	12.5	6
181.611.000.307.000	Au	4	-0.03	8	14	16	12.5	6
181.712.000.301.000	Ag	5	-0.03	9	17.5	19.5	17.5	10

Other variants, dimensions and finishes available on request.

¹ Tolerance diameter A

SPECIFICATIONS

- Suitable for all round ODU TURNTAC® sockets
- Easy and quick termination by crimping (crimp information see page [54](#))
- Suitable for connecting harmonized cables
- Part number crimping tool see table on page [56](#)



ODU ELECTRICAL CONTACTS

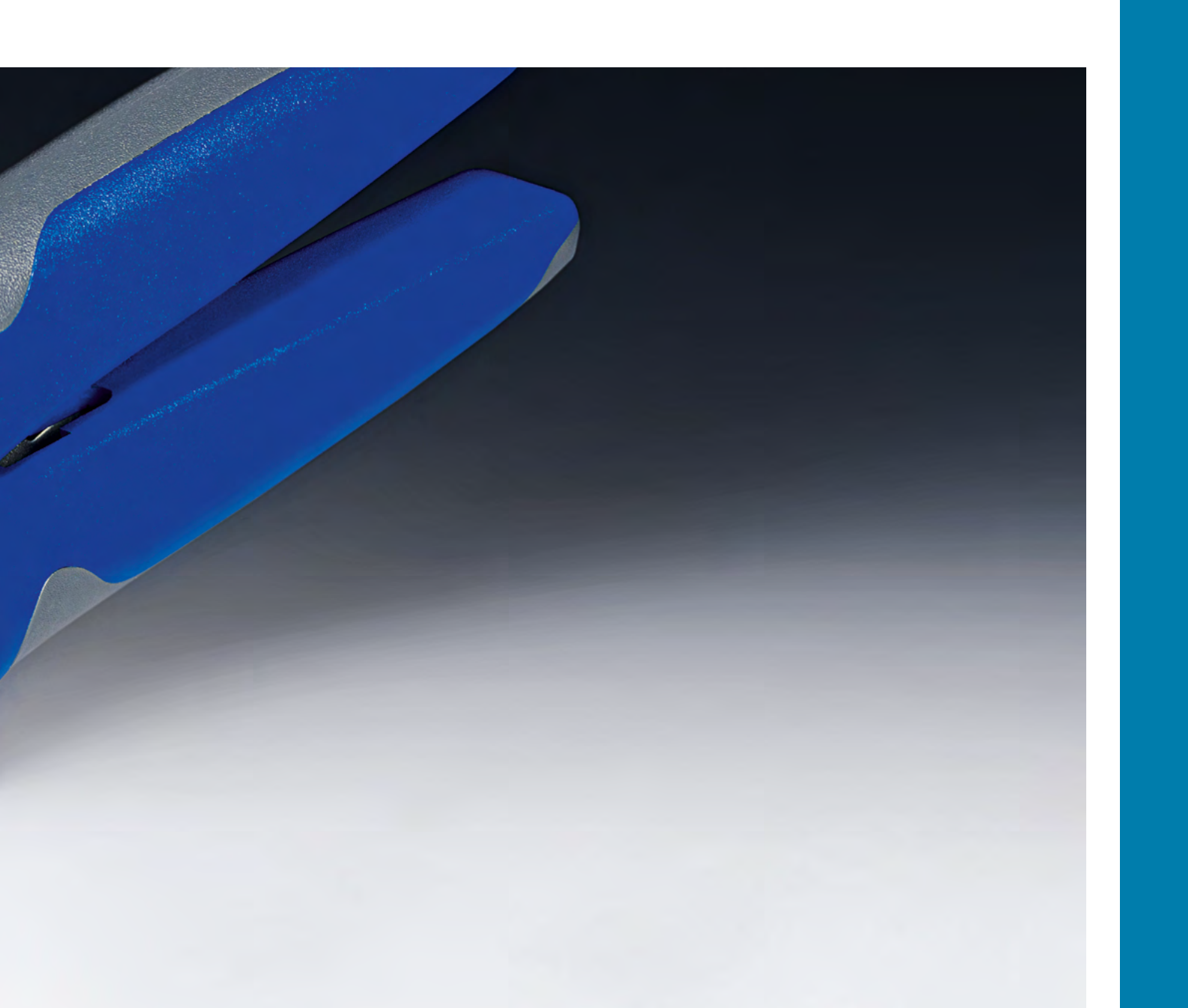

TOOLS AND ACCESSORIES

Termination technologies	<u>54</u>
Crimping tools	<u>56</u>
Conversions / AWG	<u>60</u>
Service Kit	<u>61</u>

TERMINATION TECHNOLOGIES



ODU offers three different contact termination technologies for the electrical contacts:

- Crimp
- Solder
- Screw

CRIMP TERMINATION

The contact processing for the production of connecting cables via crimping creates a secure, durable, and corrosion-free contact. For most people, crimping is easy and quick to carry out.

Through crimping, the conductor and contact materials in the compressed areas become so dense as to create a connection which is nearly gas-proof, and with a tensile strength befitting the conductor material.

Crimping can be carried out on the tiniest of cross-sections as well as on larger cross-sections. For small diameters, eight-point crimp tools are used; hexagonal crimp tools are used for larger dimensions. The corner measurement of the crimping is never larger than the original diameter. The cable insulation is not damaged in the process and can be directly attached to the connector end.

For error-free crimping, the bore diameter must be perfectly fitted to the cable. Such error-free crimping is only guaranteed if using ODU-recommended crimping tools. In order to correctly advise you, we need to know your cable type and profile, preferably by means of a sample and corresponding data sheet.

HEXAGONAL CRIMPING



8-POINT CRIMPING





SOLDER TERMINATION

Termination technology in which a molten additional metal [solder] with a lower melting point than the base materials to be connected is used to attach two metallic materials to one another. In contrast to crimping, the wire to be soldered can also be considerably smaller than the intended solder hole.

Warning: avoid unacceptable temperature increases in sockets.

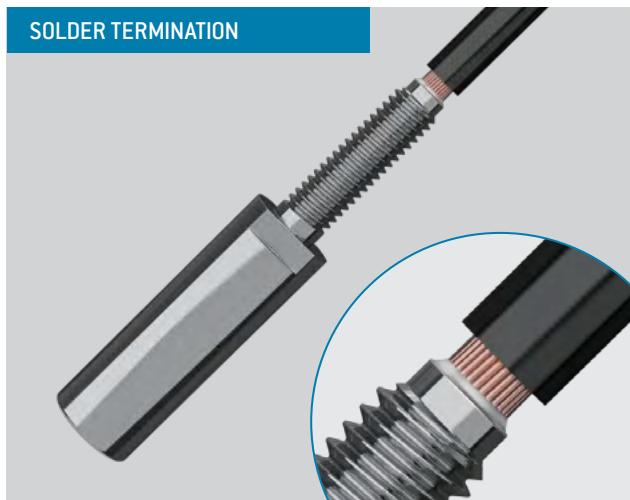

SCREW TERMINATION

This connection is established through lugs with lamellar disks and nuts. Disks and nuts are not included in standard deliveries.

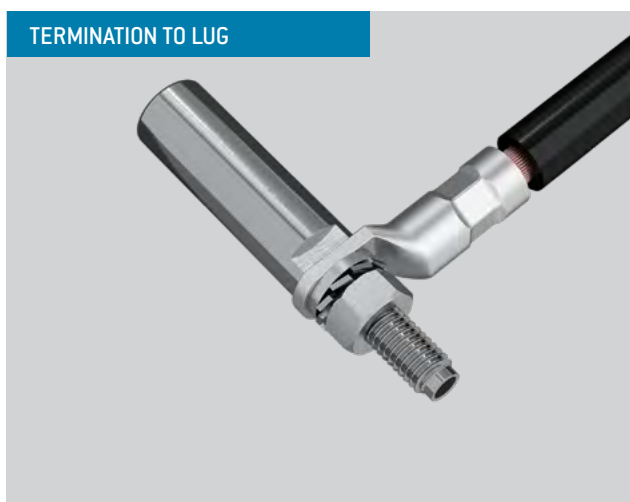

CRIMPING TOOLS

For all round ODU contacts

For further crimp information, please refer to the table on page [57](#).



8-POINT CRIMPING TOOL FOR CROSS-SECTIONS FROM 0.38 TO 0.5 mm²



PART NUMBER: 080.000.051.000.000

Hand crimping tool with user-friendly digital display and ergonomical design.

HEXAGONAL CRIMPING TOOL FOR CROSS-SECTIONS FROM 1.5 TO 6 mm²



PART NUMBER: 080.000.062.000.000

Reliable hand crimping tool with optimized power transmission and an ergonomic design for easy handling.

HEXAGONAL CRIMPING TOOL FOR CROSS-SECTIONS FROM 10 TO 50 mm²



PART NUMBER: 080.000.064.000.000

High pressing force for weaker hands due to precision mechanics. The folding head facilitates work with bulky connector forms and changing crimp inserts.

FOR CRIMPING JAWS, GO TO PAGE [57](#).

Crimping jaws must be ordered separately.

HEXAGONAL CRIMPING TOOL FOR CROSS-SECTIONS FROM 70 TO 95 mm²



PART NUMBER: 080.000.017.000.000

Very high pressing force for weaker hands due to hydraulics.

FOR CRIMPING JAWS, GO TO PAGE [57](#).

Crimping jaws must be ordered separately.

The corresponding crimp instructions can be found at www.odu-connectors.com/downloads/assembly-instructions

CRIMPING INFORMATION



Suitable for all round ODU contacts

Termination cross-section	Stripping length	8-pt-crimping tool	Hexagonal crimping tool	Mechanical hexagonal crimping tool ¹	Hydraulic hexagonal crimping tool ¹
mm ²	mm	080.000.051.000.000	080.000.062.000.000	080.000.064.000.000	080.000.017.000.000
0.38	4.5	> 0.65 < 0.7			
0.5	4.5	> 0.9 < 0.95			
1.50	7		Profile no. 1		
2.5	7		Profile no. 2		
4	7		Profile no. 3		
6	7		Profile no. 3		
10	10			080.000.064.110.000	
16	10			080.000.064.116.000	
25	18			080.000.064.125.000	
35	18			080.000.064.135.000	
50	18			080.000.064.150.000	
70	22				921.000.005.000.009
95	25				921.000.005.000.011

¹ Crimp inserts must be ordered separately.

CRIMPING TOOLS



For ODU SPRINGTAC® Flatsockets

B-PROFILE CRIMPING TOOL FOR CONDUCTOR CROSS-SECTIONS FROM 0.25–1.5 mm²



PART NUMBER: 080.000.066.000.000
Manual crimping tool with blocking system for reliable crimping

B-PROFILE CRIMPING TOOL FOR CONDUCTOR CROSS-SECTIONS FROM 1.5–4 mm²



PART NUMBER: 080.000.067.000.000
Manual crimping tool with blocking system for reliable crimping

The corresponding crimp instructions can be found at www.odu-connectors.com/downloads/assembly-instructions

CRIMPING TOOLS



Tools for ODU SPRINGTAC® Flatsockets

Size mm	Termination cross-section mm ²	Crimping tool	
		080.000.066.000.000	080.000.067.000.000
0.64 × 0.64	0.25 / 0.35 / 0.5	Profile no. 1	
1.6 × 0.6 / 0.8	0.5 / 0.75	Profile no. 2	
1.6 × 0.6 / 0.8	1	Profile no. 3	
2.8 × 0.8	1	Profile no. 4	
2.8 × 0.8	1.5	Profile no. 5	
4.8 × 0.8 / 6.3 × 0.8	1.5		Profile no. 1
	2.5		Profile no. 3
	4		Profile no. 2

Tightening torque for screw termination

Connection thread	Tightening torque (maximum) Nm
M2.3	0.1
M2.6	0.2
M3	0.5
M4	1.2
M5	2
M6	3
M8	6
M10	10
M12 × 1.5	16
M14 × 1.5	22
M16 × 1.5	30
M20 × 2	50
M24 × 2	80
M32 × 2	200

Maximum tightening torque with solid screw termination and standard material (brass).

Applies to all contacts with solder / screw termination, unless other values are indicated on the respective pages.

CONVERSIONS / AWG (AMERICAN WIRE GAUGE)



Circular wire					
AWG	Diameter		Cross-section mm ²	Weight kg/km	Max. resistance Ω/km
	Inch	mm			
4/0 [259/21]	0.6010	15.300	107.0	997.00	0.17
3/0 [259/22]	0.5360	13.600	85.0	793.00	0.22
2/0 [259/23]	0.4770	12.100	67.4	628.00	0.27
1/0 [259/24]	0.4240	10.800	53.5	497.00	0.34
1 [259/25]	0.3780	9.600	42.2	395.00	0.43
2 [259/26]	0.3350	8.500	33.6	312.00	0.55
4 [133/25]	0.2660	6.800	21.1	195.00	0.87
6 [133/27]	0.2100	5.300	13.3	122.00	1.38
8 [133/29]	0.1670	4.200	8.37	76.80	2.18
10 [1]	0.1019	2.590	5.26	46.77	3.45
10 [37/26]	0.1150	2.921	4.74	42.10	4.13
12 [1]	0.0808	2.050	3.31	29.41	5.45
12 [19/25]	0.0930	2.362	3.08	27.36	5.94
12 [37/28]	0.0910	2.311	2.97	26.45	6.36
14 [1]	0.0641	1.630	2.08	18.51	8.79
14 [19/27]	0.0730	1.854	1.94	17.23	9.94
16 [1]	0.0508	1.290	1.31	11.625	13.94
16 [19/29]	0.0590	1.499	1.23	10.928	15.70
18 [1]	0.0403	1.020	0.823	7.316	22.18
20 [1]	0.0320	0.813	0.519	4.613	35.10
20 [7/28]	0.0390	0.991	0.563	5.003	34.10
20 [19/32]	0.0420	1.067	0.616	5.473	32.00
22 [1]	0.0253	0.643	0.324	2.883	57.70
22 [19/34]	0.0330	0.838	0.382	3.395	51.80
24 [1]	0.0201	0.511	0.205	1.820	91.20
24 [7/32]	0.0250	0.635	0.227	2.016	86.00
24 [19/36]	0.0270	0.686	0.241	2.145	83.30
26 [1]	0.0159	0.404	0.128	1.139	147.00
26 [7/34]	0.0200	0.508	0.141	1.251	140.00
26 [19/38]	0.0220	0.559	0.154	1.370	131.00
28 [1]	0.0126	0.320	0.0804	0.715	231.00
28 [7/36]	0.0160	0.406	0.0889	0.790	224.00
28 [19/40]	0.0170	0.432	0.0925	0.823	207.00
30 [1]	0.0100	0.254	0.0507	0.450	374.00
30 [7/38]	0.0130	0.330	0.0568	0.505	354.00
32 [1]	0.0080	0.203	0.0324	0.288	561.00
32 [7/40]	0.0110	0.279	0.0341	0.303	597.10
34 [1]	0.0063	0.160	0.0201	0.179	951.00
34 [7/42]	0.0070	0.180	0.0222	0.197	1,491.00
36 [1]	0.0050	0.127	0.0127	0.1126	1,519.00
36 [7/44]	0.0060	0.150	0.0142	0.1263	1,322.00

The American Wire Gauge (AWG) is based on the principle that the cross-section of the wire changes by 26 % from one gauge number to the next. The AWG numbers decrease as the wire diameter increases, while the AWG numbers increase as the wire diameter decreases. This only applies to solid wire.

However, stranded wire is predominately used in practice. This has the advantage of a longer service life under bending and vibration as well as greater flexibility in comparison with solid wire.

Stranded wires are made of multiple, smaller-gauge wires [higher AWG number]. The stranded wire is assigned the AWG numbers of a solid wire with the next closest cross-section to that of the stranded wire. In this case, the cross-section of the stranded wire refers to the sum of the copper cross-sections of the individual wires.

Accordingly, strands with the same AWG number but different numbers of wires differ in cross-section. For instance, an AWG 20 strand of 7 AWG 28 wires has a cross-section of 0.563 mm², while an AWG 20 strand of 19 AWG 32 wires has a cross-section of 0.616 mm².

Source: ASTM

SERVICE KIT FOR ALL ELECTRICAL CONTACTS



Contact lubrication improves the mechanical properties of contact systems. Cleaning the contact surfaces prior to lubrication is also recommended in order to remove pollution. With appropriate care, wear due to high mating frequency can be significantly minimized and the mating and demating forces reduced. The cleaning and lubricating interval must be individually adapted to circumstances and should only be carried out with products recommended by the contact manufacturer.

ODU has put together a Service Kit for this purpose, so that lubrication can be carried out directly on site. A cleaning brush and a special cleaning cloth, as well as precise instructions, help to ensure optimal care of the contacts. In the absence of other specifications, the Service Kit can be used for all ODU contacts and connections.

PART NUMBER: 170.000.000.000.100

To reorder individual tubes of the lubricant:

ORDER NUMBER: 50270079

For technical properties of the Service Kit, please refer to our website: www.odu-connectors.com/downloads

CLEANING INFORMATION

Service manual 003.170.000.000.000

FURTHER INFORMATION

Never submerge the connector in liquid. The connector may only be put back into operation again when it has been assured that it is completely dry.

Ensure that contact pins are not bent or otherwise damaged. The connector must no longer be used if damage or other signs of wear are detected. Clean with maximum 2.5 bar compressed air to avoid contact damage. A slight blackening of the contact points may occur over the course of the service life and represents no impairment of the electrical properties.

Recommended cleaning agent

Soap: liquid soaps on sodium bicarbonate or potassium base

Alcohol: ethanol 70 %, isopropyl alcohol 70 %

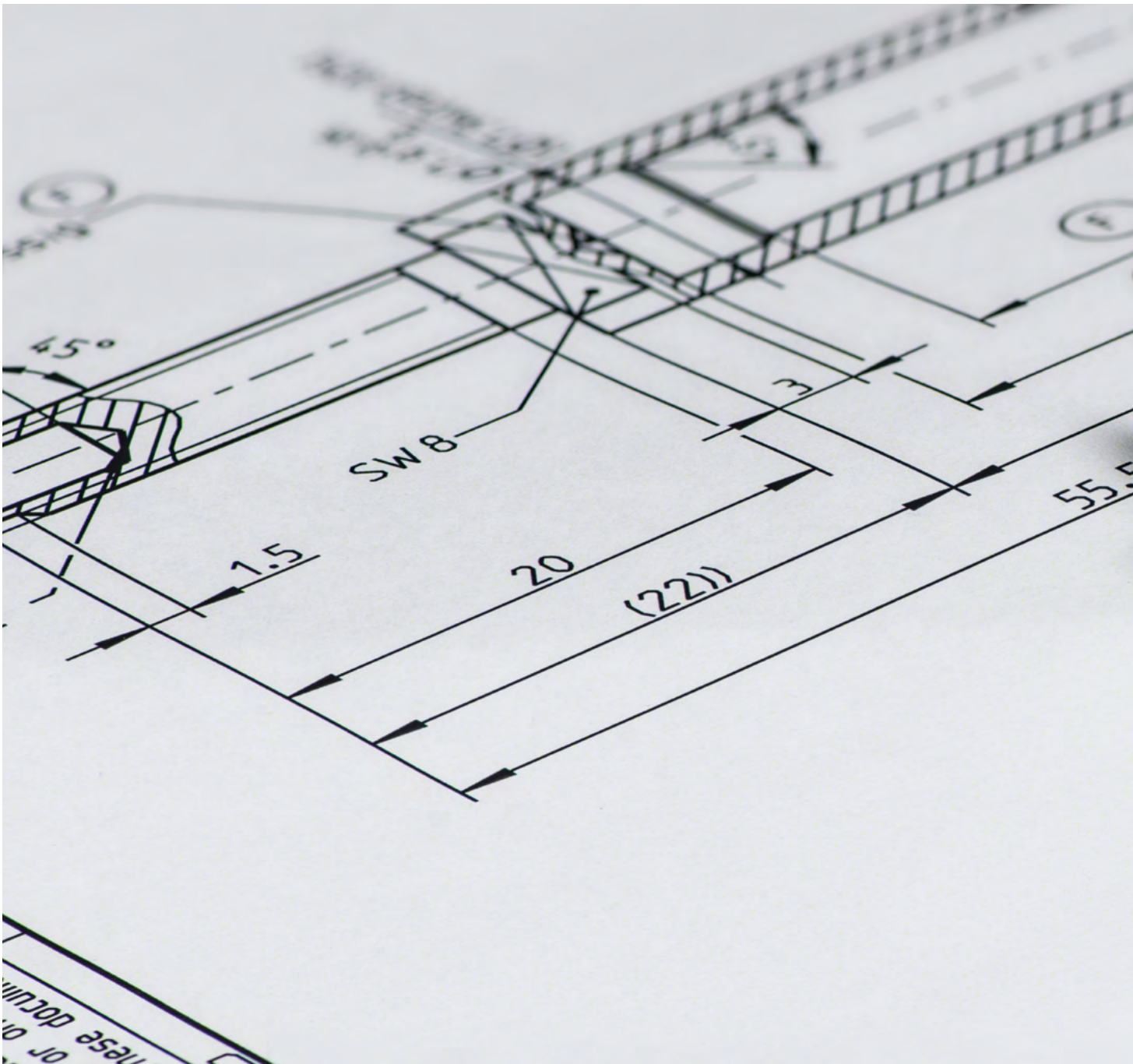

ODU ELECTRICAL CONTACTS



TECHNICAL INFORMATION

Current-carrying capacity	64
Installation instructions	68
Chamber dimensions for ODU SPRINGTAC® Flatsockets	70
Technical terms	72

BASIC PRINCIPLES OF CURRENT-CARRYING CAPACITY



Derating measurement procedure IEC 60512-5-2:2002 (DIN EN 60512-5-2:2003-01).

STRUCTURE OF THE BASE CURRENT-CARRYING CAPACITY CURVE

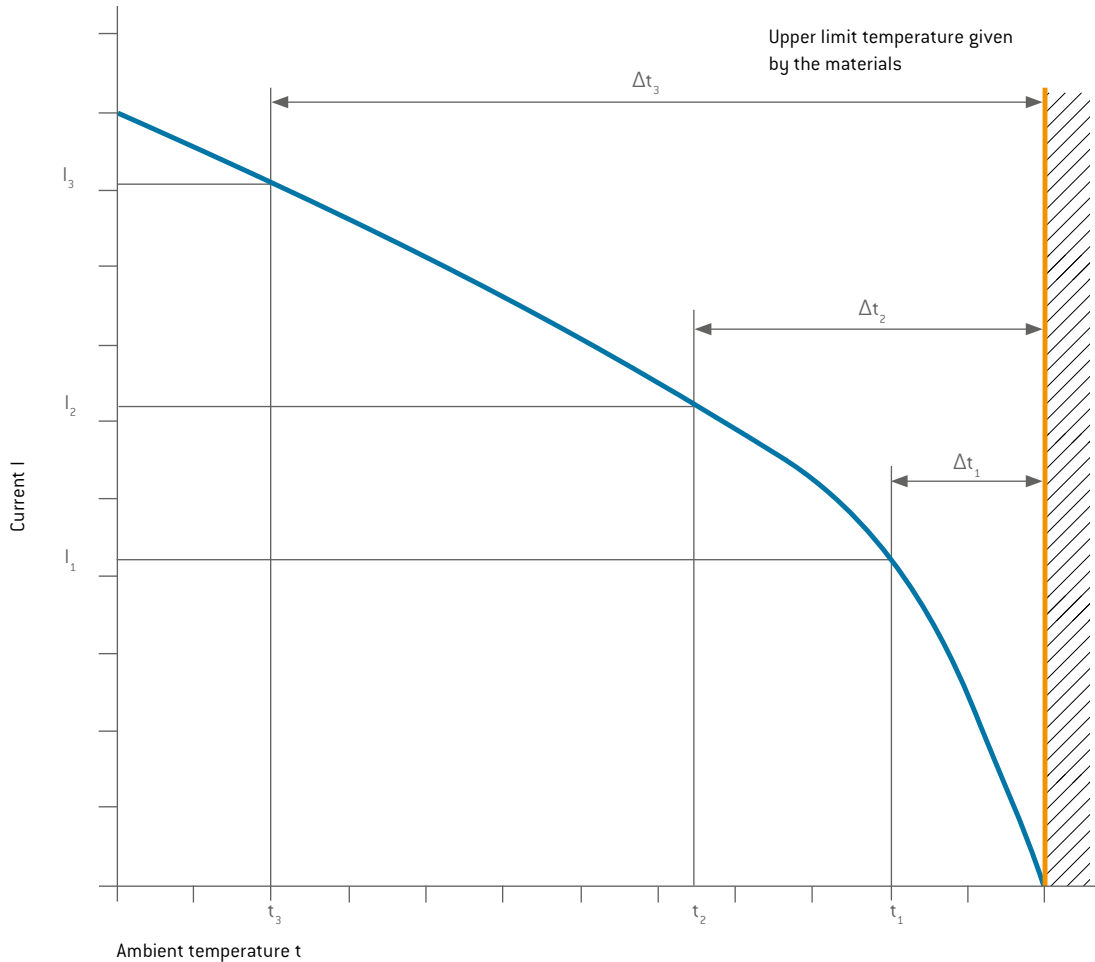

The current-carrying capacity of a connector is determined by measurement. It is determined by taking into account the self-heating due to current heat and the ambient temperature, and is limited by the thermal properties of the contact materials used; the upper limit temperatures of these materials should not be exceeded.

The relationship between current, the resulting temperature increase, conditioned by the dissipation loss at the contact resistance, and the ambient temperature is represented in a curve.

The curve is drawn in a linear coordinate system with the current “I” as the ordinate and the temperature “t” as the abscissa. The upper limit temperature forms the limit of the diagram.

In three measurements, the temperature rise due to Joule heat (Δt) is determined at different currents in at least three connectors and the points determined in this process are connected into a parabolic basis curve.

The corrected current-carrying capacity curve (**derating curve**) can be derived from the basis curve. The safety factor ($0.8 \times I_n$) also makes allowance for factors such as manufacturing tolerances and uncertainties in temperature measurement or the measuring arrangement.

CURRENT-CARRYING CAPACITY DIAGRAM

ODU SPRINGTAC®

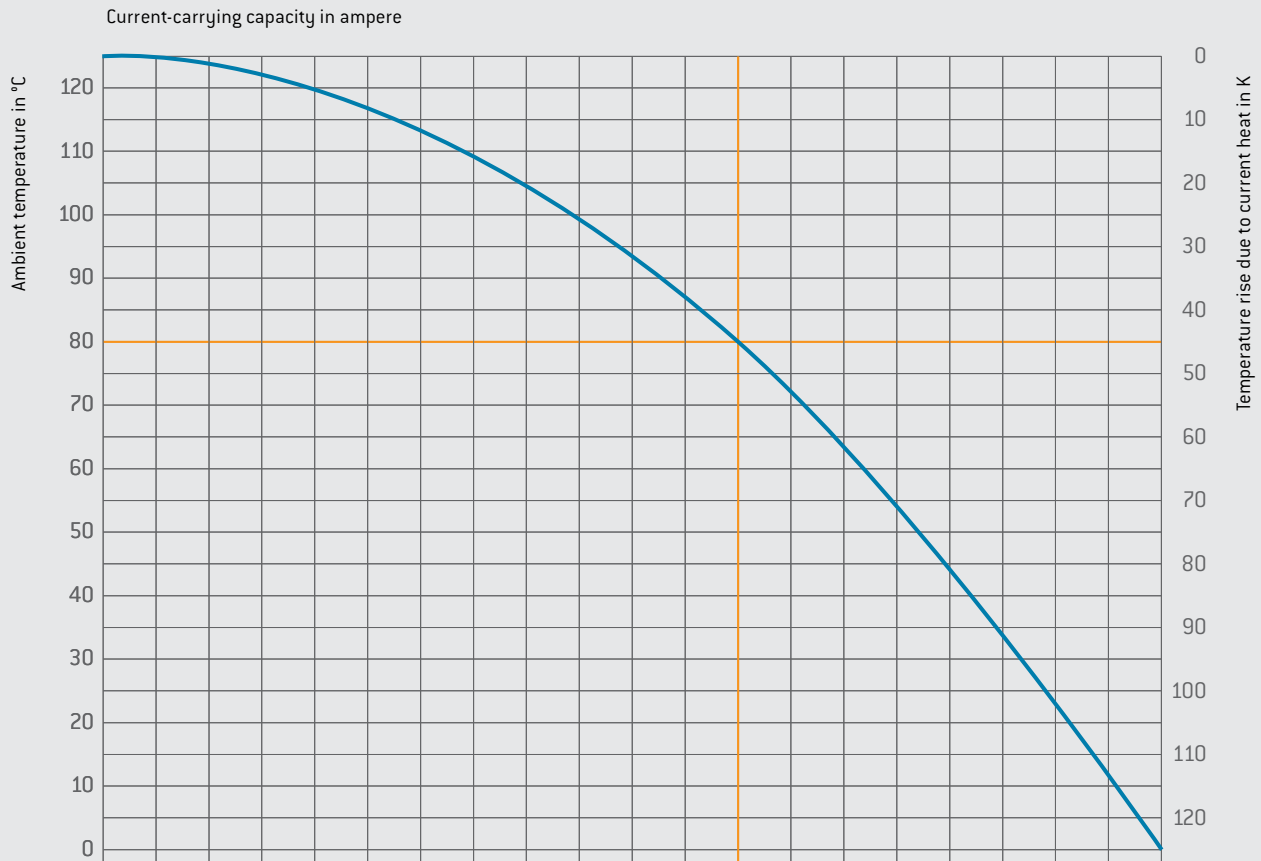

Contact-Ø mm	Nominal current											Max. continuous current	
Ø 0.76	0	1.5	3.5	5	6.5	8	10	11.5	13	15	16.5		
Ø 1.02	0	2	4	6	8	10	12	14	16	18	20		
Ø 1.5	0	4	8	12	16	20	25	27	31	35	40		
Ø 2	0	5	10	15	20	25	30	35	40	45	50		
Ø 2.5	0	5	10	15	20	25	30	35	40	45	50		
Ø 3	0	5	15	20	25	30	40	50	55	65	70		
Ø 4	0	10	20	25	35	45	55	60	70	80	90		
Ø 5	0	12	25	40	50	65	75	90	100	115	125		
Ø 6	0	15	30	50	65	80	100	115	130	145	160		
Ø 8	0	25	45	70	90	115	140	160	180	200	220		
Ø 10	0	30	60	85	115	145	175	200	230	265	295		
Ø 12	0	40	75	110	150	190	230	265	300	345	385		
Ø 14	0	45	90	140	185	230	280	320	360	405	460		
Ø 16	0	55	110	165	220	280	340	380	420	465	510		
Ø 18	0	60	120	180	245	310	375	430	480	525	580		
Ø 20	0	75	150	220	295	370	450	500	550	605	670		
Ø 22	0	80	160	235	315	400	480	540	590	655	720		
Ø 24	0	80	165	245	330	410	500	575	640	705	780		
Ø 26	0	85	175	260	350	435	530	600	675	755	835		
Ø 28	0	105	215	320	425	535	650	710	780	855	940		
Ø 30	0	120	235	350	470	590	720	800	875	955	1,035		
Ø 36	0	150	300	440	590	740	900	1,000	1,100	1,205	1,310		

Measurement in accordance with IEC 60512-5-2:2002 (DIN EN 60512-5-2:2003-01) (base curve is shown).
 Upper limit temperature +125 °C. Connection with the largest specified nominal cross-section.

CURRENT-CARRYING CAPACITY DIAGRAM

ODU LAMTAC®

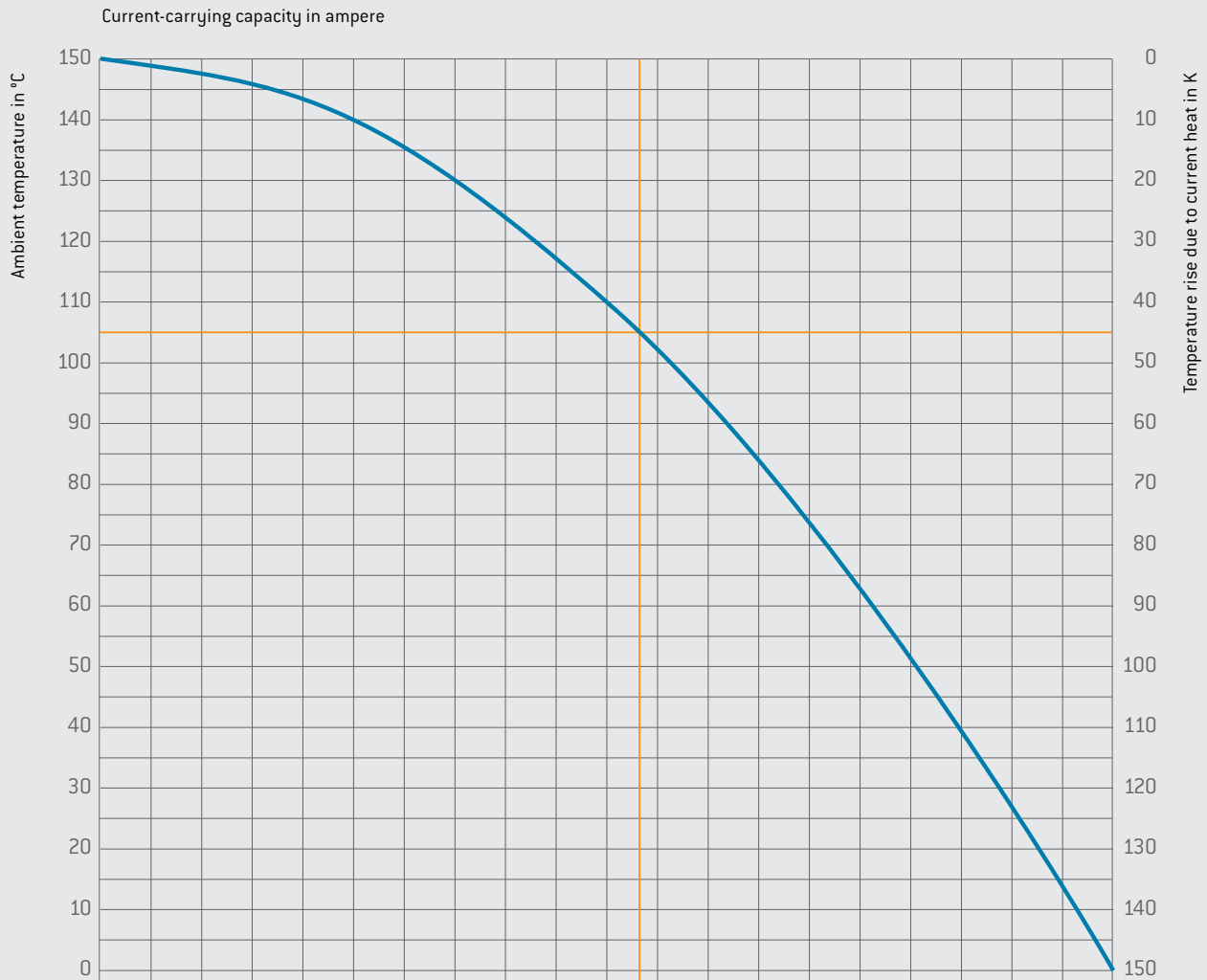

Contact diameter mm	Nominal current										Max. continuous current	
	0	1	7	11	16	22	28	36	47	54	62	67
Ø 1.5	0	1	7	11	16	22	28	37	42	49	52	
Ø 2	0	1	9	14	21	28	36	47	54	62	67	
Ø 3	0	1	12	19	28	38	50	66	76	88	95	
Ø 4	0	1	15	25	35	50	65	85	100	115	125	
Ø 5	0	1	25	35	55	70	90	120	135	155	170	
Ø 6	0	1	35	55	80	110	145	195	225	260	280	
Ø 8	0	1	40	70	105	140	185	245	285	330	355	
Ø 10	0	1	50	85	130	170	230	310	355	410	445	
Ø 12	0	1	50	85	130	175	235	315	360	420	455	
Ø 16	0	1	90	145	210	280	370	490	560	650	700	
Ø 20	0	1	115	185	275	370	490	650	750	870	935	
Ø 24	0	1	140	240	365	495	670	910	1,055	1,235	1,340	
Ø 28	0	1	190	320	485	655	885	1,195	1,375	1,610	1,745	
Ø 30	0	1	220	365	545	735	990	1,330	1,535	1,790	1,940	

Measurement in accordance with IEC 60512-5-2:2002 (DIN EN 60512-5-2:2003-01) (base curve is shown).
 Upper limit temperature +150 °C. Connection with the largest specified nominal cross-section.

CURRENT-CARRYING CAPACITY DIAGRAM

ODU TURNTAC®

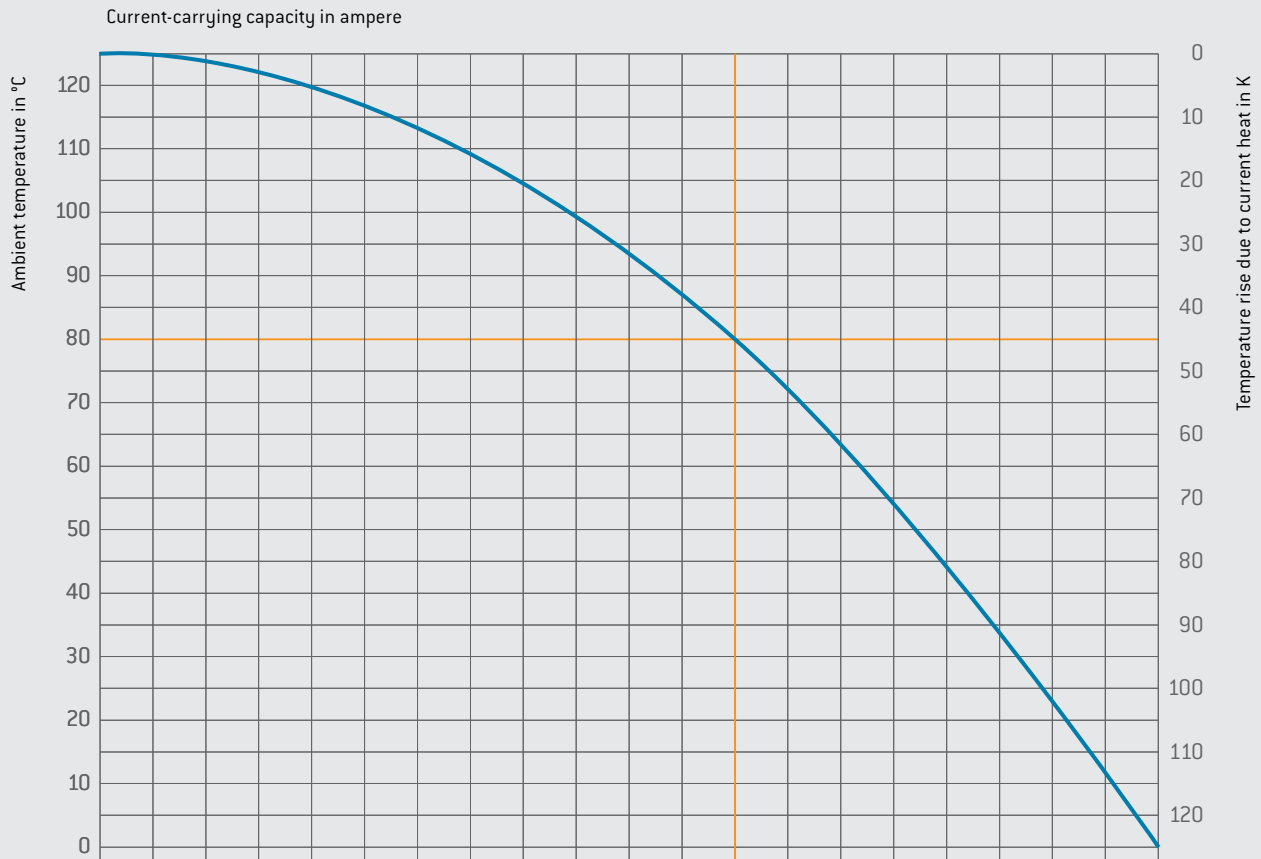

Contact diameter mm	Nominal current										Max. continuous current										
Ø 1.5	0		4		8		13		17		21		25		30		34		39		43
Ø 2	0		6		11		17		23		29		34		41		47		53		58
Ø 3	0		8		17		25		33		41		50		58		67		75		84
Ø 4	0		10		19		29		39		48		55		68		78		90		97
Ø 5	0		13		26		39		52		65		75		91		104		120		130
Ø 6	0		16		33		50		65		82		100		115		132		150		164
Ø 8	0		21		42		63		84		105		125		148		168		190		210
Ø 10	0		28		56		84		112		140		165		195		220		250		275

Measurement in accordance with IEC 60512-5-2:2002 (DIN EN 60512-5-2:2003-01) (base curve is shown).
 Upper limit temperature +125 °C. Connection with the largest specified nominal cross-section.

INSTALLATION INSTRUCTION



INSTALLATION CLEARANCE

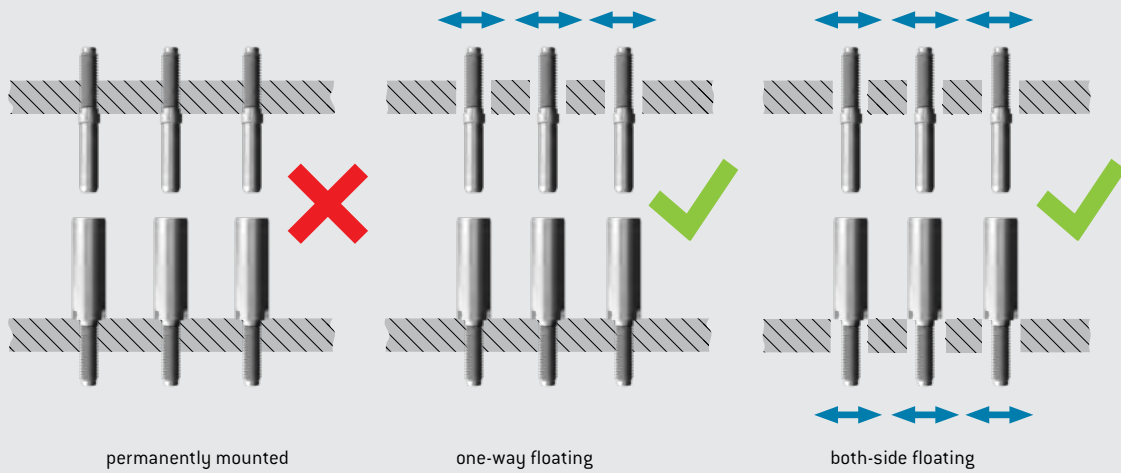

ODU contact systems can be used both as single contacts and in multi-position connectors. One side (pin or socket side) or both sides should always have a “floating” mounting in order to compensate for any manufacturing and assembly tolerances in the individual system components.

MAXIMUM PERMISSIBLE OFFSET (RADIAL PLAY)

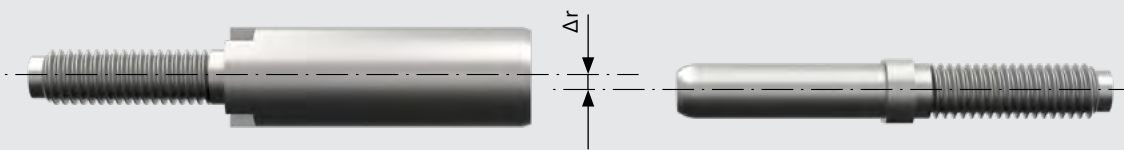

Nominal contact diameter mm	max. Δr mm
$\leq \varnothing 2$	0.02
$\leq \varnothing 4$	0.05
$\leq \varnothing 14$	0.1
$\leq \varnothing 30$	0.2

Our ODU contact series are able to compensate for the radial displacements of the insertion axis. The figure shows a representation with radial axis displacement. The contact springs or louvres are still making contact with the mating surfaces and consequently continue to ensure full contact safety.



DEVIATION ANGLE INSERTION AXIS

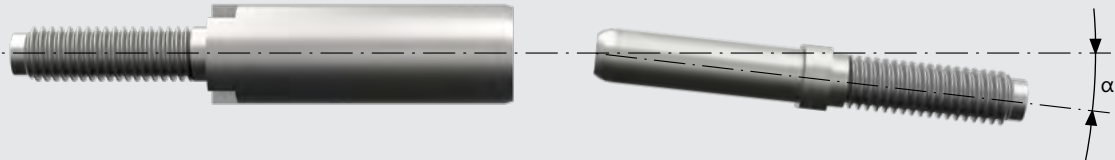

Contact system	max. α
ODU SPRINGTAC®	$\pm 1^\circ$
ODU LAMTAC®	$\pm 1^\circ$
ODU TURNTAC®	$\pm 5^\circ$

The deviation angle of the insertion axis of the pin and socket should be as small as possible. It is especially important to consider this when implementing a “floating” assembly position.

GENERAL INFORMATION

- ODU contact systems are not suitable for guiding a plug-in system. Components should be separately provided in order to implement a preliminary guidance piece. Preliminary guidance pieces are always recommended.
- For the technical design of the coupling forces for complete connectors, as well as any drives, locking cylinders and the like, we recommend applying a safety factor of at least 3 to the force values specified in the catalog.
- Non-compliance with the installation instructions may lead to malfunction or damage.

OUR TEAM WILL BE HAPPY TO ANSWER
ANY QUERIES YOU MAY HAVE:
electrical-contacts@odu.de

ODU SPRINGTAC® FLATSOCKETS



CHAMBER DIMENSIONS FOR 0.64 × 0.64 mm

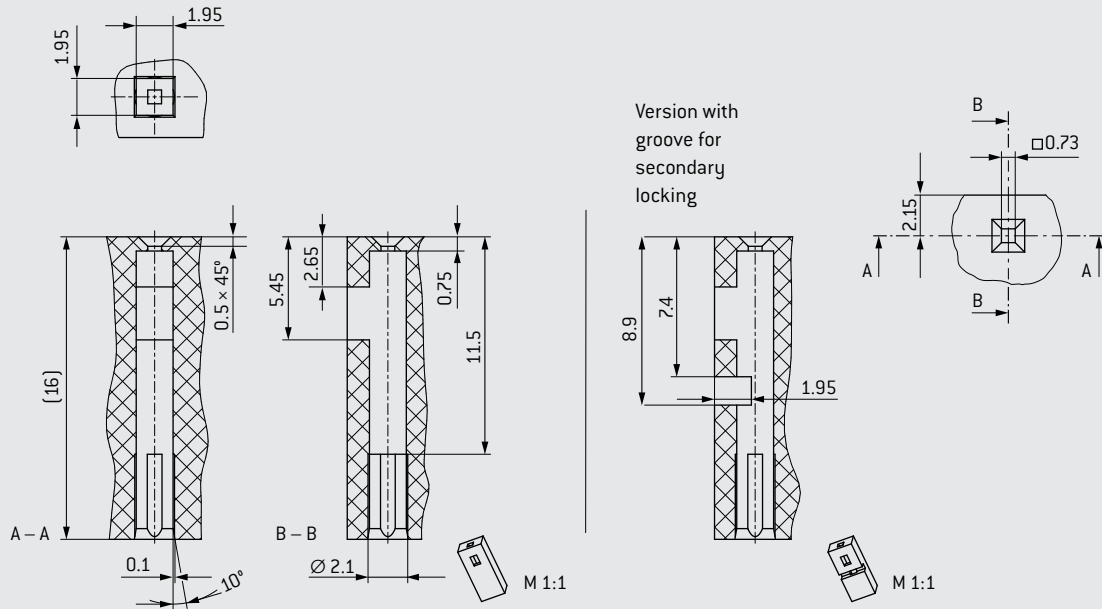

CHAMBER DIMENSIONS FOR 1.6 × 0.6 / 0.8 mm

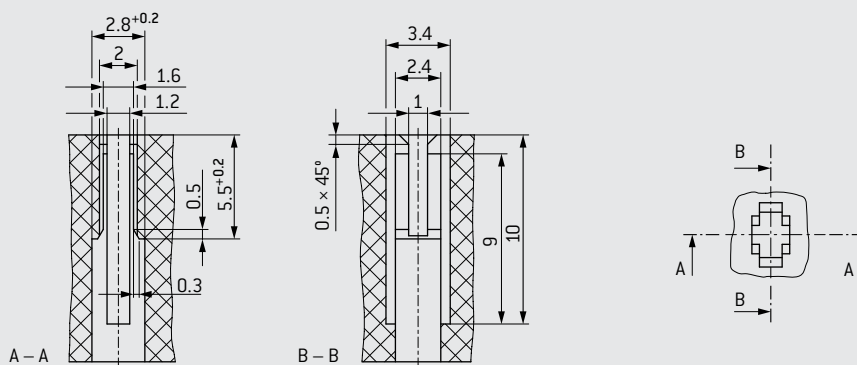

ODU SPRINGTAC® FLATSOCKETS



CHAMBER DIMENSIONS FOR 2.8 × 0.8 mm¹

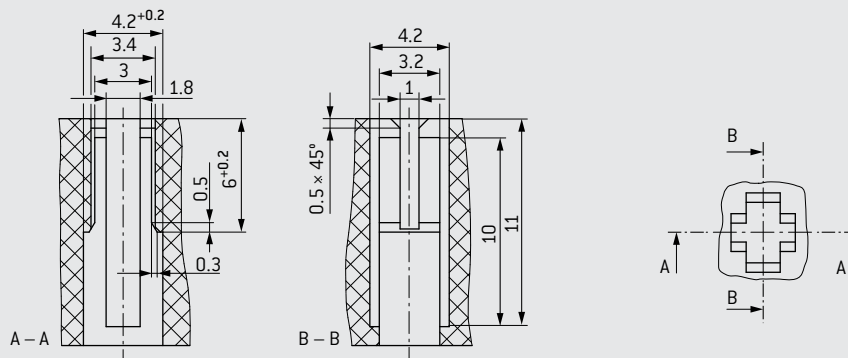

CHAMBER DIMENSIONS FOR 6.3 × 0.8 (4.8 × 0.8) mm¹

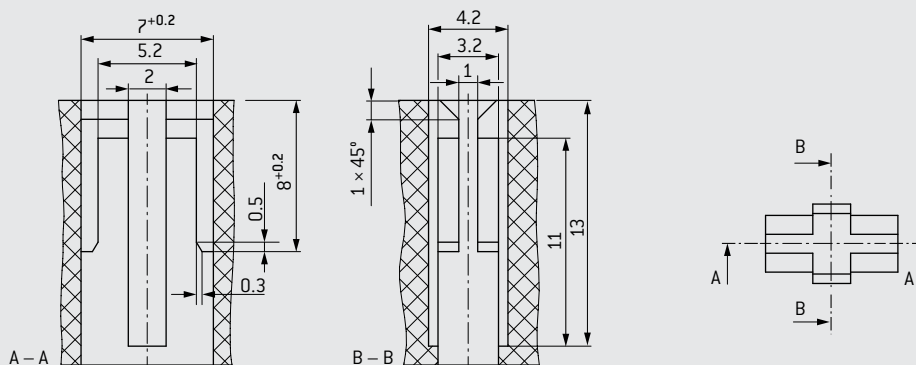

Dimensions without tolerances in accordance with ISO 2768-1:1989-11 and ISO 2768-2:1989-11 [DIN ISO 2768-1:1991-06 and DIN ISO 2768-2:1991-04], fine.

¹ Slightly increased mating and demating forces apply for the articles 190.224 000 and 190.225 000.

TECHNICAL TERMS



CORE

Electrical conductor, solid wire or multi-wire strand, with insulation as well as any conductive layers. Cables or lines may have one or more cores.

TERMINATION CROSS-SECTION (Q)

The specified cross-sections < 240 mm² correspond to a “fine-wire” conductor structure in accordance with IEC 60228:2004 (VDE 0295:2005-09; Class 5). For larger cross-sections, the specifications refer to copper busbars.

TERMINATION TECHNOLOGIES

Methods for connecting the leads to the electro-mechanical elements, such as solder-free connections in accordance with IEC 60352-2:2006+A1:2013 (DIN EN 60352-2:2014-04): crimp, screw connection, etc. or soldered connection (see page [54](#)).

AWG

American Wire Gauge (see page [60](#)).

BASE CURVE

Metrologically established current-carrying capacity curve for connectors in accordance with the measurement procedure described in IEC 60512-5-2:2002 (DIN EN 60512-5-2:2003-01) depending on the permissible limit temperature of the materials (see page [64](#)).

RATED CURRENT (NOMINAL CURRENT)

The metrologically determined current which is permitted to flow continuously through all contacts at the same time and will increase the contact temperature by 45 Kelvin. The amperage is determined according to the derating measurement method (IEC 60512-5-2:2002 (DIN EN 60512-5-2:2003-01)) and derived from the base curve.

OPERATING TEMPERATURE

Range between the uppermost and lowermost temperature limits.

ODU SPRINGTAC®	–40 °C to +125 °C
ODU SPRINGTAC® Flatsocket	–40 °C to +125 °C
ODU LAMTAC®	–40 °C to +150 °C
ODU TURNTAC®	–40 °C to +125 °C

CRIMPING AREA

The specified area of the crimp barrel in which the crimp termination is executed by means of deforming or shaping the barrel under pressure around the conductor.

CRIMP BARREL

A conductor barrel which can accommodate one or more conductors and be crimped by a crimping tool.

CRIMP CONNECTION (CRIMP TERMINATION)

The permanent, non-detachable and solder-free mounting of a contact to a conductor via deforming or shaping under pressure to make a good electrical and mechanical connection. Executed with crimping tool, press or automatic crimping machine (see page [54](#)).

DERATING CURVE

The corrected current-carrying capacity curve, derived from the base curve determined (0.8 x measured current). It factors in manufacturing tolerances as well as uncertainties in temperature measurement and measurement arrangement (see derating measurement method).

DERATING MEASUREMENT PROCEDURE

IEC 60512-5-2:2002 (DIN EN 60512-5-2:2003-01)

Measurement method to determine the current-carrying capacity of connectors in consideration of the maximum permissible limit temperature (see page [64](#)).

WIRE

Wires (solid conductors) are available with an insulating sleeve and/or electrical shielding. Cables or conductors may be made up of one or more wires.

CONTACT RESISTANCE

Total resistance value measured from terminal to terminal. In this case, the resistance is significantly lower than the contact resistance. The specifications are average values.

SOLDER CONNECTION (SOLDER TERMINATION)

Termination technology in which a molten additional metal (solder) with a lower melting point than the base materials to be connected is used to attach two metallic materials to one another. All technical information does not refer to the solder termination by means of the soldering hole (ØL).

MAX. CONTINUOUS CURRENT

The measured amperage at room temperature (approx. 20 °C) which increases the contact temperature to the limit temperature. The values specified in the catalog apply to either individual contacts or completely assembled inserts / modules, as indicated.

TECHNICAL TERMS



NOMINAL CURRENT IEC 60512-5-2:2002 (DIN EN 60512-5-2:2003-01)

See rated current.

UPPER LIMIT TEMPERATURE

The highest permissible temperature at which the connector may still be operated. It includes contact heating due to the current load (see operating temperature). Please consult ODU for high-temperature applications.

LUBRICATION

All standard contacts are lubricated at the factory. We recommend the ODU Service Kit for subsequent lubrication (see [61](#)).

MATING AND DEMATING FORCE

The force required to fully insert or withdraw pluggable elements without the influence of a coupling or locking device. The values refer to contacts in new condition. The data represents average values with a potential fluctuation of $\pm 50\%$. For the technical design of the coupling forces for complete connectors, as well as any drives, locking cylinders and the like, we recommend applying a safety factor of at least 3 to the force values specified in the catalog.

CONNECTORS

Also known as connectors without contact rating (COC): IEC 61984:2008 (VDE 0627:2009-11). An element which enables electrical conductors to be connected and is intended to create and/or separate connections with a suitable counterpart.

CONNECTORS WITH BREAKING CAPACITY (CBC) (PLUG DEVICE)

A connector which, when used correctly, may be mated or demated when live or under load.

MATING CYCLES

Mechanical actuation of connectors via push and pull action. A mating cycle consists of one insertion and withdrawal action. Standard value for:

ODU SPRINGTAC®	100,000
ODU SPRINGTAC® Flatsocket	50,000
ODU LAMTAC®	10,000
ODU TURNTAC®	10,000

These values are subject to the following conditions: clean environment, appropriate radial guidance, impeccable counterpins. Further instructions for correct installation can be found in the general installation instructions (see page [68](#)).

SURGE CURRENT

One-time impulse current with a 10 ms load duration.

CURRENT-CARRYING CAPACITY (NOMINAL CURRENT AND MAXIMUM CONTINUOUS CURRENT)

The data relates to adequately dimensioned connection cables in accordance with IEC 60228:2004 (VDE 0295:2005-09; Class 5), so that no significant temperature increase occurs here. The indicated temperature increase takes place through the contact. The specifications are average values.

AMBIENT TEMPERATURE

Temperature of the air or other medium in which a piece of equipment is intended to be used (IEC 60204-1:2016 (VDE 0113-1:2019-06)).

LOWERMOST LIMIT TEMPERATURE

The lowest permissible temperature at which a connector may be operated (see operation temperature).

MATERIALS (STANDARD DESIGN)

Pins and carriers of the sockets are manufactured from a CuZn alloy and silver or gold-plated. The lamellas consist of a CuBe alloy and are also silver or gold-plated. The springwire contact wires consist of a CuSn alloy and are also silver or gold-plated.

GENERAL NOTE

The connectors listed in this catalog are intended for use in high voltage and frequency ranges. Suitable precautionary measures must be taken to ensure that people do not come into contact with live conductors during installation and operation.

All entries in this catalog were thoroughly reviewed before printing. ODU reserves the right to make changes based on the current state of knowledge without prior notice without being obliged to provide replacement deliveries or refinements of older designs.

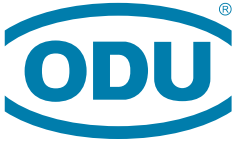

A PERFECT ALLIANCE.

ODU GROUP WORLDWIDE

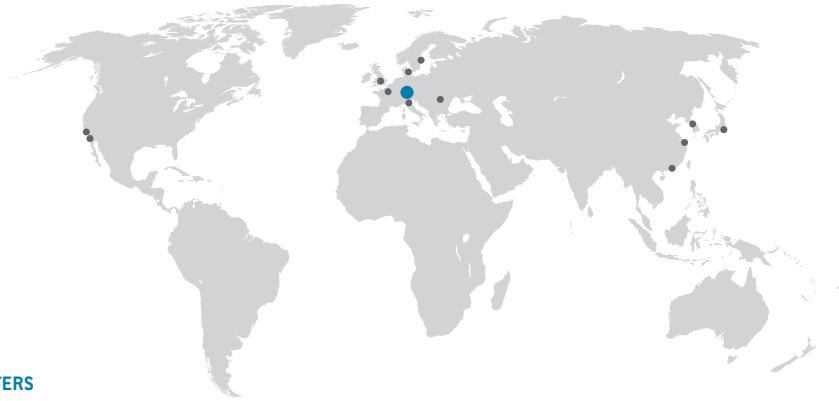

HEADQUARTERS

ODU GmbH & Co. KG

Pregelstraße 11, 84453 Mühldorf a. Inn, Germany
Phone: +49 8631 6156-0, Fax: +49 8631 6156-49, E-mail: sales@odu.de

SALES LOCATIONS

ODU (Shanghai)

International Trading Co., Ltd.
Phone: +86 21 58347828-0
E-mail: sales@odu.com.cn
www.odu.com.cn

ODU Italia S.R.L.

Phone: +39 331 8708847
E-mail: sales@odu-italia.it
www.odu-italia.it

ODU Scandinavia AB

Phone: +46 176 18262
E-mail: sales@odu.se
www.odu.se

ODU (HK) Trading Co., Ltd.

Phone: +852 5439-9036
E-mail: sales@odu.hk
www.odu.hk

ODU Japan K.K.

Phone: +81 3 6441 3210
E-mail: sales@odu.co.jp
www.odu.co.jp

ODU-UK Ltd.

Phone: +44 330 002 0640
E-mail: sales@odu-uk.co.uk
www.odu-uk.co.uk

ODU Denmark ApS

Phone: +45 2233 5335
E-mail: sales@odu-denmark.dk
www.odu-denmark.dk

ODU Korea Inc.

Phone: +82 2 6964 7181
E-mail: sales@odu-korea.kr
www.odu-korea.kr

ODU-USA Inc.

Phone: +1 805 484-0540
E-mail: sales@odu-usa.com
www.odu-usa.com

ODU-France SARL

Phone: +33 1 3935-4690
E-mail: sales@odu.fr
www.odu.fr

ODU Romania Manufacturing SRL

Phone: +40 269 704638
E-mail: sales@odu-romania.ro
www.odu-romania.ro

Further information and specialized representatives can be found at:

www.odu-connectors.com/contact

PRODUCTION AND LOGISTICS SITES

Germany	Otto Dunkel GmbH
China	ODU (Shanghai) Connectors Manufacturing Co., Ltd.
Mexico	ODU Mexico Manufacturing S. de R.L. de C.V.
Romania	ODU Romania Manufacturing SRL
USA	ODU North American Logistics Inc.



Simply scan the QR code to download the entire publication.

All dimensions are in mm. Some figures are for illustrative purposes only. Subject to change without notice. Errors and omissions excepted. We reserve the right to change our products and their technical specifications at any time in the interest of technical improvement. This publication supersedes all prior publications. This publication is also available as a PDF file that can be downloaded from www.odu-connectors.com

ODU-CK-MUE

ODU-ELECTRICAL CONTACTS / C / 04-20 / EN