

CATV/BROADBAND

2018 PRODUCT GUIDE

The Next Generation Technology

Clarke & Severn Electronics
Ph + 612 9482 1944
Email sales@clarke.com.au
www.cseonline.com.au



 **Mini-Circuits®**



DOCSIS 3.1 Typical Block Diagram

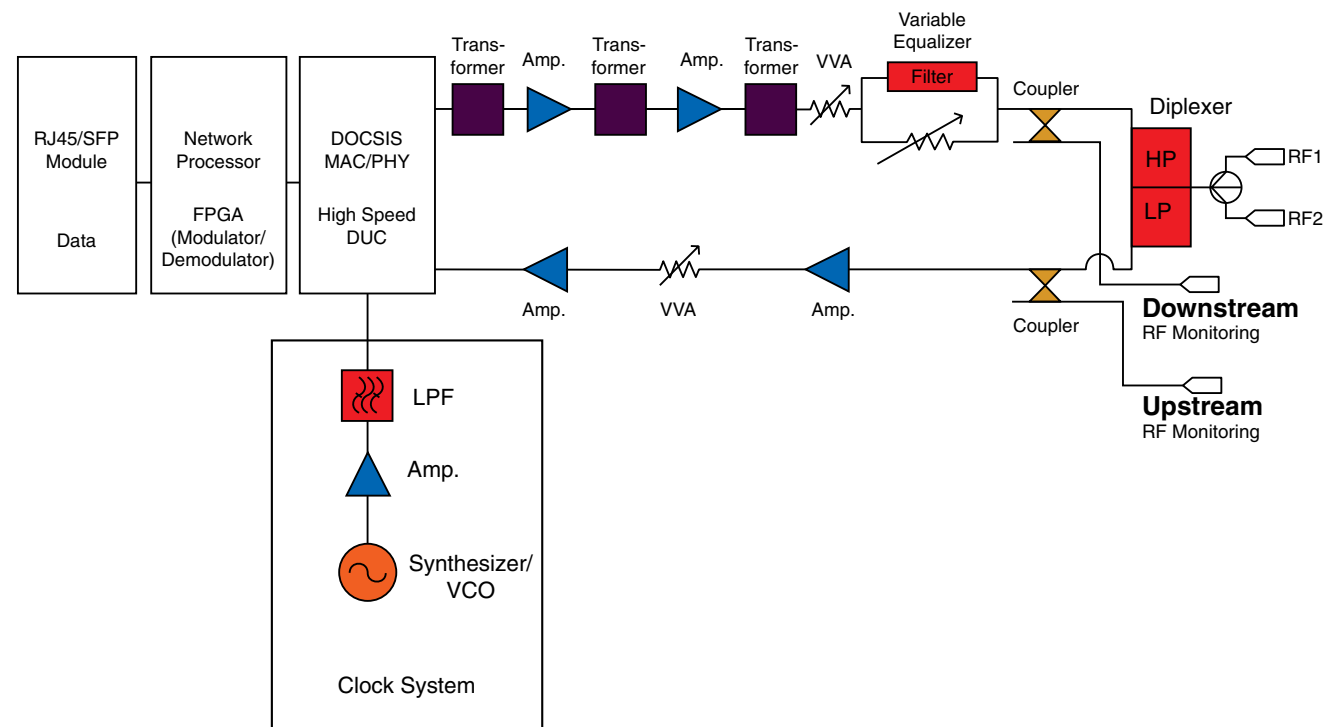

CONTENTS

Introduction	4
Precision Test and Measurement of 75Ω Products	5
Amplifiers	6-7
Control Products	8-9
• Voltage Variable Attenuators	
• Voltage Variable Equalizers	
Couplers	10-11
Filters/Diplexers	12-13
Splitter/Combiners	14-15
Switches	16-17
Test Accessories	18-19
• Matching Pads	
• Test Cables	
• USB Power Sensor	
Transformers	20-21
VCOs	22-23



DOCSIS is a registered trademark of CableLabs. Neither Mini-Circuits nor the this publication, nor any of the products presented herein are affiliated with or endorsed by the above referenced trademark.

All Products are **RoHS Compliant**
The "+" suffix identifies RoHS compliance. See our website for RoHS compliance methodologies and qualifications

INTRODUCTION

The Industry's Widest Variety of RF Products for the Next Generation of Broadband Applications

As consumer demand for higher data capacity continues to intensify, network operators deploying optical and hybrid fiber-coaxial (HFC) infrastructure continue to push the limits of their equipment to operate under the DOCSIS ® 3.1 standard. Competition at the operator level is driving rapid and continuous development, testing, and certification of new equipment. To meet the new standards and accelerate time to market, program managers, system designers and purchasing managers in the broadband space need components with tightly specified performance and high reliability with value pricing and fast delivery.

Mini-Circuits is deeply committed to supporting equipment manufacturers and operators in the CATV/broadband market as the standards and technology continue to evolve. Many of our components have been designed into DOCSIS 3.1 applications from head-end infrastructure to customer-premises equipment, and we've gained extensive experience working with customers at the engineering level to achieve design success. In the process, we have expanded our portfolio of off-the-shelf parts with a wide variety of new models developed especially to support the evolving needs of the broadband market.

We're very pleased to present our updated product offering for the next generation of CATV and broadband applications in our CATV/Broadband 2018 Product Guide. Inside you'll find information on a wide range of RF components from passive devices including transformers, couplers, and splitter/combiners to active elements including amplifiers, equalizers and more – all designed and carefully specified to meet DOCSIS 3.1 standards. We hope this material gives you a convenient reference to make an informed decision as you evaluate parts for your design.

With the industry's broadest variety of off-the-shelf RF/IF and microwave products, chances are, we have you covered, but even if you don't see what you need here, we're always here to support you. We invite you to get in touch with our applications team (apps@minicircuits.com) to discuss any questions or special requirements you may have. Our engineers can design custom components to meet your exact requirements for low cost and with exceptionally fast turnaround times.

Thank you for your interest in Mini-Circuits and our extensive offering of RF products for advanced CATV/broadband applications. We hope this information gives you a valuable tool in your search for the right components to make your project a success.

Sincerely,

Ted Heil
President
Mini-Circuits

PERFORMANCE YOU CAN COUNT ON:

Precision Test and Measurement of 75Ω Products

Meeting the new standards for data over cable systems demands components that perform reliably to meet the precise requirements of your design. Mini-Circuits has long been highly regarded in the industry for the sophistication of our test and measurement techniques, and our expertise in this area enables us to qualify the performance of our products for broadband applications to a superior level of accuracy. Characterizing RF products for use in CATV and broadband networks poses the unique problem performing test and measurement of 75Ω components using the industry standard 50Ω vector network analyzer equipment. The accuracy and precision of this testing depends entirely on the measurement method employed.

Two traditional methods for performing these measurements are building matching circuits for each DUT into test fixtures and back-to-back transformer measurement. Building matching circuits to compensate for impedance mismatch could require dozens of different matching circuits to test different components, which makes it both costly and impractical. Furthermore, compensating for the losses of matching circuits affects measurement accuracy. Back-to-back transformer measurement is also dependent on the matching and losses of the transformers used and therefore only provides an approximation of the real performance of the DUT.

Fortunately, in recent years the RF industry introduced vector network analyzers capable of performing virtual impedance conversion or "Z-conversion." Measurement with virtual impedance conversion avoids the need for test fixtures with matching circuits, eliminating the problem of compensating for loss. The fixture is used with 50Ω at all ports, calibration is performed using a 50Ω calibration kit, and then auto port extension and Z-conversion are applied. This method allows precision measurement of components with 75Ω impedance and is especially effective with passive components such as splitters, couplers and transformers.

By using virtual impedance conversion to characterize the performance of our 75Ω product portfolio, Mini-Circuits is able to provide our customers with tight performance specifications for every product we produce. In the broadband cable market where high demand and competition are driving requirements for high system performance and speed to market, designers need parts they can rely on to meet those requirements. As you evaluate parts for your design, it's important to consider how suppliers are qualifying performance given the special challenges of test and measurement for 75Ω products. With Mini-Circuits, you can know we're using the most advanced tools and the most accurate measurement methods available, so you can have confidence in the performance of our products.

For more information about test and measurement at Mini-Circuits, we invite you to reach out to us. Our engineers are ready to discuss any questions or special requirements you may have. We're here to support you!

Contact:
Mini-Circuits Applications
apps@minicircuits.com

AMPLIFIERS

AMPLIFIERS

Our selection of amplifiers for CATV and broadband systems provides frequency ranges supporting both upstream and downstream bandwidth requirements for the DOCSIS 3.1 standard. These amplifiers provide outstanding dynamic range and gain flatness, enabling excellent system performance across broad bandwidths. Manufactured using E-PHEMT and InGap HBT technology on GaAs, they come in packages as small as SOT-89 with designed-in ESD protection and excellent unit-to-unit repeatability.

FEATURES

- Flat Gain
- High Dynamic Range
- Low Noise
- Discrete and Dual-Matched Models
- Upstream and Downstream Bands
- Tiny Size

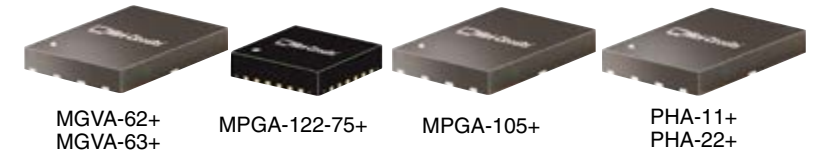

Dual Matched MMICs

Model Number	Frequency Range (MHz)	Gain (dB) Typ.	NF (dB)	P1dB (dBm)	Out. IP3 (dBm)	Input VSWR	Voltage (V)	DC Current (mA)
MGVA-62+	40-3000	15.7	4.8	19.6	37.9	1.65	5	82
MGVA-63+	40-3000	21.4	3.6	19.4	34.3	1.35	5	69
MPGA-122-75+	40-1250	15.3	3.2	30.6	48.8	1.21	9	391
MPGA-105+	40-3000	14.4	1.9	21	37.8	1.2	5	63
PHA-11+	50-3000	15	2.3	21.4	41.5	2.1	5	146
PHA-22+	50-1500	16	1.9	22	41	1.5	5	146



Ultra-High Dynamic Range MMICs

Model Number	Frequency Range (MHz)	Gain (dB) Typ.	NF (dB)	P1dB (dBm)	Out. IP3 (dBm)	Input VSWR	Voltage (V)	DC Current (mA)
PGA-106R-75+	5-250	17.9	3.3	19.5	34.4	1.4	5	116
PGA-32-75+	5-300	15.6	2.9	23.7/18.7	43.3/39.1	1.16	9.0/5.0	110/55
PGA-122-75+	5-1500	15.5	2.8	23.8	41.4	1.26	9	115
PGA-106-75+	50-1500	16.9	3.3	20.1	36.2	1.4	5	116

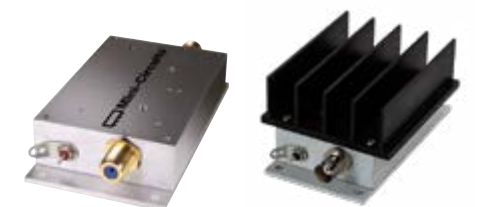

Connectorized Amplifiers

Model Number	Frequency Range (MHz)	Gain (dB) Typ.	NF (dB)	P1dB (dBm)	Out. IP3 (dBm)	Input VSWR	Voltage (V)	DC Current (mA)
ZHL-132LM-75+	40-1300	14.4	3.5	24.5	45.5	1.3	6	258
ZHL-1010-75+	50-1000	9.5	3.5	26	47	1.5	12	525

CONTROL PRODUCTS

CONTROL PRODUCTS

Mini-Circuits voltage variable attenuators and equalizers are perfect for systems where precise control over signal strength is needed. Our VVAs are ideal for adjusting the amplitude of input/output signals in Automatic Level Control (ALC) circuits, and our Voltage Variable Equalizers allow operators to compensate for cable losses without having to measure the length of each cable, saving significant cost and resources deployed in the field. All models are designed for 75Ω networks and characterized to meet DOCSIS 3.1 bandwidth requirements!

VOLTAGE VARIABLE ATTENUATOR FEATURES

- Attenuation from 18 to 40 dB
- High linearity, +50 dBm IP3
- No external bias or matching required
- Low power consumption
- Ideal for adjusting input/output signals in ALC circuits

75Ω VOLTAGE VARIABLE EQUALIZER FEATURES

- Adjustable attenuation slope
- High linearity, +50 dBm IP3
- Low deviation from linear loss, ±0.5 dB
- Low power consumption
- Enables easy compensation for cable loss



Case HE 1354

75Ω Voltage Variable Equalizer

Equalizers Model Number	F Low (MHz)	F High (MHz)	Insertion Loss@ Freq. Low	Insertion Loss@ Freq. High	IP3 Typ.	Control Volt. (V)	Control Current (mA) Max.
VAEQ-1220-75+	50	1220	15-1.7	3.1-1.6	50	0-7	20



EVA-2-75+

75Ω Voltage Variable Attenuators

Model Number	Frequency Range (MHz)	Insertion Loss (dB) @ Control Voltage (V).	Insertion Loss (dB), Typ.	Attenuation (dB) @ Control Voltage (V)	Attenuation (dB)	IP3 (dBm)	Return Loss (dB)	Supply Voltage (V)	DC Current (mA) Max.	Control Voltage (V)	Control Current (mA) Max.
EVA-2-75+	50-2000	8	2.7	0	30	49	25	5	3	0-8	40
EVA-23-75+	10-2000	8	4.7	0	33	50	16	3	4	0-8	15



COUPLERS *Directional/Bi-Directional*



DIRECTIONAL / BIDIRECTIONAL COUPLERS

With over 30 standard catalog models specified for DOCSIS 3.1 requirements, Mini-Circuits' wide selection of directional couplers spans coupling values from 6 to 46 dB. Core and wire models feature Mini-Circuits unique Top Hat® feature to improve speed and accuracy of pick and place assembly. All models offer flat coupling across frequency, low mainline loss, and good directivity.*

FEATURES

- Coupling from 6 to 48 dB
- Excellent Coupling Flatness
- Low Mainline Loss
- High Directivity
- Power Handling up to 1W
- Top Hat® Feature on Core and Wire Models

*Model BDCH46-122-75+ is a stripline coupler with variable coupling vs. frequency. This model can be paired with a fixed equalizer on the coupled line to achieve flat coupling across its full bandwidth while preserving the low loss of its stripline design. See application note AN-30-008 on our website for more information.

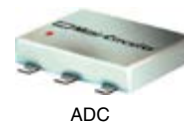

Model Number	F Low (MHz)	Coupling (dB) Nom.	Mainline Loss (dB) Typ.	Directivity (dB) Typ.	Power Input Max. (W)	Type
ADC-6-10-75+	20-1000	6.6	2.1	15	0.5	Directional
ADC-8-4-75+	5-1250	7.9	1.6	17	1	Directional
ADC-10-4-75+	5-1250	10.5	0.9	18	1	Directional
ADC-12-4-75+	20-1250	12.6	0.9	23	1	Directional
ADC-15-4-75+	5-1000	15.5	0.7	20	1	Directional
ADC-16-4-75+	5-1250	16.2	0.7	30	1	Directional
ADC-17-122-75+	5-1250	17	0.8	12	1	Directional
ADC-18-4-75+	20-1000	17.4	0.4	18	1	Directional
ADC-20-4-75+	5-1250	19.7	0.5	23	1	Directional
ADC-25-4-75+	5-1250	25	0.1	25	1	Directional

Model Number	F Low (MHz)	Coupling (dB) Nom.	Mainline Loss (dB) Typ.	Directivity (dB) Typ.	Power Input Max. (W)	Type
BDCH46-122-75+	40-1250	14-46	0.15	19	2	Bi-Directional
SYBDC-9-122-75+	5-1218	9.5	1.3	13	1	Bi-Directional



DBTC-6-4-75+

DBTC-6-4-75+	5-1250	6.8	2.2	17	1.0	Directional
DBTC-9-4-75L+	5-1200	9.3	1.3	20	0.7	Directional
DBTC-10-13L+	5-1000	10.3	1.4	18	1	Directional
DBTC-12-4-75+	5-1200	12	1.1	19	0.5	Directional
DBTC-13-5-75L+	5-1500	13.2	1.4	19	1	Directional
DBTC-16-5-75L+	5-1500	16.3	1.3	21	1	Directional
DBTC-18-4-75L+	5-1000	18.2	0.8	21	1	Directional
DBTC-20-4-75L+	5-1250	20.5	0.8	19	1	Directional



LRDC-10-2W-75+

LRDC-10-2W-75+	30-1200	10	1	21	1	Directional
----------------	---------	----	---	----	---	-------------



RDC-17-122-75X+



RDC-10-122-75X+

RDC-10-122-75X+	5-1250	10	1.2	20	1	Directional
RDC-17-122-75X+	5-1250	17.6	0.8	20	1	Directional



TCD-6-122-75X+

TCD-6-122-75X+	5-1250	6.7	2.3	12	0.5	Directional
TCD-9-1W-75X+	5-2000	8.9	1.8	15	1	Directional
TCD-10-122-75X+	5-1250	10	1.5	15	1	Directional
TCD-16-122-75X+	5-1250	16.5	1.5	22	1	Directional
TCD-13-122-75X+	5-1250	12.7	1	15	1	Directional
TCD-18-122-75X+	5-1250	17.5	1	22	1	Directional
TCD-20-4-75+	40-1200	20	0.6	23	1	Directional
TCD-20-4-75X+	40-1200	20	0.6	23	1	Directional



Z30 & ZFDC

Z30-16-5-75+	5-1500	16.5	1.1	24	1	Directional
Z30-18-4-75+	5-1000	18.5	0.85	23	1	Directional

ZFDC-10-21-75	10-750	11	1.5	30	2	Directional
---------------	--------	----	-----	----	---	-------------

FILTERS & DIPLEXERS

HIGH PERFORMANCE FILTERS & DIPLEXERS

Mini-Circuits offers a wide variety of filters and diplexers for CATV and broadband systems and equipment, with design technologies including LTCC, ceramic resonator, lumped-LC and more. Our 75Ω diplexers are specially designed for duplexing multiband signals into two channels with various channel splits within the DC to 1220 MHz band to meet various system requirements.

FEATURES

- Insertion Loss as low as 0.8 dB
- High Out-of-Channel Rejection, 50 dB
- Power Handling up to 14.5W
- Various Channel Splits
- Surface Mount, Coaxial and Field Replaceable Plug-In Models



Filters

Model Number	Description	Passband F1-F2 (MHz)	Stopband F3 (MHz)	Rejection @ F3 (dB)	Stopband F4 (MHz)	Rejection @ F4 (dB)
BFCN-152W-75+	LTCC Band Pass Filter, 950-1970 MHz	950-1970	630-730	20	2300-3000	20
CSBP-B1300-75+	Ceramic Resonator Band Pass Filter, 1210-1390 MHz	1210-1390	DC-1080	20	1545-2500	20
SXBP-1430-75+	Lumped LC Band Pass Filter, 950-2150 MHz	950-2150	540	20	2950	20
SXBP-45-75+	Lumped LC Band Pass Filter, 5-85 MHz	5-85	DC-1	20	116-3000	20

Diplexers



DPLB-2025A0+

Model Number	Passband (MHz)	Passband IL (dB)	Rejection (dB)	Return Loss (dB)	Crossover Isolation (dB)
DPLB-2025A0+	DC-204 258-1220	1	50 @ 258-1220 55 @ DC-204	23 21	40
DPLB-4254A0+	DC-42 54-1220	0.8	50 @ 54-1220 50 @ DC-42	18	-
DPLB-6585A0+	5-65 85-1220	1	50 @ 85-1220 55 @ 5-65	24	40
DPLB-8510A01+	DC-85 102-1220	1.4	50 @ 102-1220 50 @ DC-85	18 16	-
DPLB-8510A04+	5-85 102-1220	0.7 1	48 @ 102-1220 48 @ 5-85	24	9



DPLC-2025A0+

DPLC-2025A0+	DC-204 258-1220	1	45 @ 258-1220 50 @ DC-204	24	40
DPLC-4254A0+	DC-42 54-1220	1	50 @ 54-1220 50 @ DC-42	24	40
DPLC-8510A0+	DC-85 102-1220	1.1 1.4	50 @ 102-1220 50 @ DC-85	24	15



DPLX-4254A0+

DPLX-4254A0+	DC-42 54-1000	0.9	50 @ 54-1000 50 @ DC-42	20 18	-
DPLX-6588A0+	DC-65 88-1000	1	50 @ 88-1000 50 @ DC-65	18	-



ZDPL-2025-75-F+

ZDPL-2025-75-F+	258-1700 DC-204	1	50 @ DC-204 65 @ 258-1700	20 24	37
ZDPL-4254-75-F+	54-1700 5-42	1	50 @ 5-42 50 @ 54-1700	22 24	40
ZDPL-6588-75-F+	88-1700 5-65	1.2 1	50 @ 5-65 50 @ 88-1700	20	35
ZDPL-8510-75-F+	102-1400 5-85	1.6 1.4	45 @ 5-85 50 @ 102-1400	20 22	30

SPLITTERS / COMBINERS



SPLITTERS / COMBINERS

Mini-Circuits offers over 30 off-the-shelf RF splitter/combiners for CATV/broadband applications. Our selection includes models from 2 to 24 ways in a variety of case styles including surface mount, coaxial, and field-replaceable plug-in designs. All models provide low insertion loss, high isolation, and minimal phase and amplitude unbalance.

FEATURES

- Models from 2-Way to 24-Way
- Insertion Loss as low as 0.3 dB
- High Isolation, up to 36 dB
- Low Phase and Amplitude Unbalance (as low as 2° / 0.2 dB)
- Power Handling up to 10W
- Surface-Mount, Coaxial, and Field-Replaceable Plug-In Models

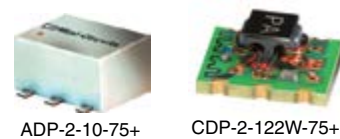

Model Number	Interface	No. of Ways	Freq. Range (MHz)	Isolation (dB)	Insertion Loss (dB) Above Theoretical	Phase Unbalance (deg)	Amplitude Unbalance (dB)	Power Input (W) as Splitter, Max.
ADP-2-10-75+	SMT	2	50-1000	24	0.7	2	0.2	0.5
ADP-2-10-75M+	SMT	2	5-1200	28	0.7	4	0.3	1
ADP-2-10W-75+	SMT	2	5-1000	23	0.3	3	0.2	0.5
ADP-2-122-75+	SMT	2	5-1250	22	0.9	2	0.2	0.5
ADP-2-20-75+	SMT	2	5-2000	16	0.5	4	0.3	0.5
CDP-2-122W-75+	SMT	2	1-1250	21	0.8	1.5	0.25	1
CDP-2-13-75+	SMT	2	5-1000	25	0.6	3	0.3	1

Model Number	Interface	No. of Ways	Freq. Range (MHz)	Isolation (dB)	Insertion Loss (dB) Above Theoretical	Phase Unbalance (deg)	Amplitude Unbalance (dB)	Power Input (W) as Splitter, Max.
PSC-2-1-75+	Plug in	2	0.25-300	30	0.4	3	0.2	1
PSC-3-1-75+	Plug in	3	1-200	35	0.3	3	0.2	1
PSC-4-1-75+	Plug in	4	1-200	25	0.5	3	0.2	1
PSC-4-1W-75+	Plug in	4	0.5-400	24	0.7	2	0.2	1
PSC-4A-1W-75+	Plug in	4	30-600	22	0.8	4	0.7	1
PSC-8-1-75+	Plug in	8	0.5-175	30	0.6	2.5	0.2	1



SBTC-2-10-75X+	SMT	2	10-1000	28	0.6	3	0.6	0.5
SBTC-2-10-75LX+	SMT	2	10-1000	28	0.6	3	0.6	0.5
SBTC-2-15-75X+	SMT	2	500-1500	28	0.8	5	0.9	0.5
SBTC-2-15-75LX+	SMT	2	500-1500	28	0.8	5	0.9	0.5
SCA-4-10-75+	SMT	4	10-1000	30	1.5	9	0.9	0.5
SCP-4-4-75+	SMT	4	10-1000	32	0.65	6	0.4	1
SCPA-8-13-75+	SMT	8	5-1050	20	2.5	5	4	1



SYPS-2-282-75+	SMT	2	2-2750	20	0.5	2	0.2	0.5
SYPS-3-12W-75+	SMT	3	20-1200	22	1.2	4	0.7	1
SYPS-3-152-75+	SMT	3	5-1500	24	1	2	0.4	1
TCP-2-10-75X+	SMT	2	5-1000	29	0.3	4	0.6	0.5
TCP-2-122-75X+	SMT	2	5-1250	24	0.9	1.5	0.4	0.5
TCP-2-152-75X+	SMT	2	5-1500	28	0.8	1.5	0.25	0.5
TCP-2-182-75X+	SMT	2	10-1800	26	0.8	2	0.15	0.5
TCP-2-23-75+	SMT	2	900-2300	18	0.8	3	0.4	0.5
ZAPD-2-252-75+	Con	2	5-2500	26	0.6	3	0.4	0.5
ZB8PD-242-75-F+	Con	8	600-2400	27	0.7	3	0.3	10
ZB16PD-272-75F+	Con	16	695-2700	20	1.2	5	0.5	5



ZFRSC-2075+	Con	2	DC-2000	6.6	0.3	2	0.2	0.75
ZFSC-3-4-75+	Con	3	1-1000	27	0.4	6	0.7	1
ZFSC-4-175W+	Con	4	5-1000	36	0.5	3	0.2	1
ZFSC-8-4-75+	Con	8	5-1000	25	0.6	7	0.5	1
ZFSC-12-1W-75	Con	12	5-860	30	0.8	8	0.8	1
ZFSC-24-11-75	Con	24	1-200	33	0.8		0.4	1

MMIC SWITCHES

HIGH-POWER REFLECTIVE MMIC SWITCHES

For highly reliable signal routing in CATV and broadband systems, Mini-Circuits offers a series of 75Ω MMIC switches made using Silicon-on-Insulator process technology with built-in CMOS drivers. Available in SPDT, SP3T, SP4T, SP5T and SP6T designs, they provide extremely fast switching, low insertion loss, high isolation, and high IP3 in tiny packages with very low current consumption.

FEATURES

- Fast switching, 1.9 μs
- Insertion Loss as low as 0.38 dB
- High Isolation, up to 42 dB
- High IP3, up to +56 dBm
- High Power Handling, up to 3W
- Low Current Consumption, as low as 37 μA
- Tiny Size, 2x2mm



Model Number	Type	Freq. Low (GHz)	Freq. Hi (GHz)	Driver	Insertion Loss (dB), Typ.	1 dB Compression (dBm), Typ.	In-Out Isolation (dB), Typ.
JSW2-33DR-75+	SPDT	0.005	3	CMOS	0.4	35	35
JSW2-33HDR-75+	SPDT	0.005	3	CMOS	0.3	35	35
JSW3-23DR-75+	SP3T	0.005	2	CMOS	0.8	35	32
JSW4-23DR-75+	SP4T	0.005	2	CMOS	0.8	35	32
JSW5-23DR-75+	SP5T	0.005	2	CMOS	0.8	35	32
JSW6-23DR-75+	SP6T	0.005	2	CMOS	0.8	35	32

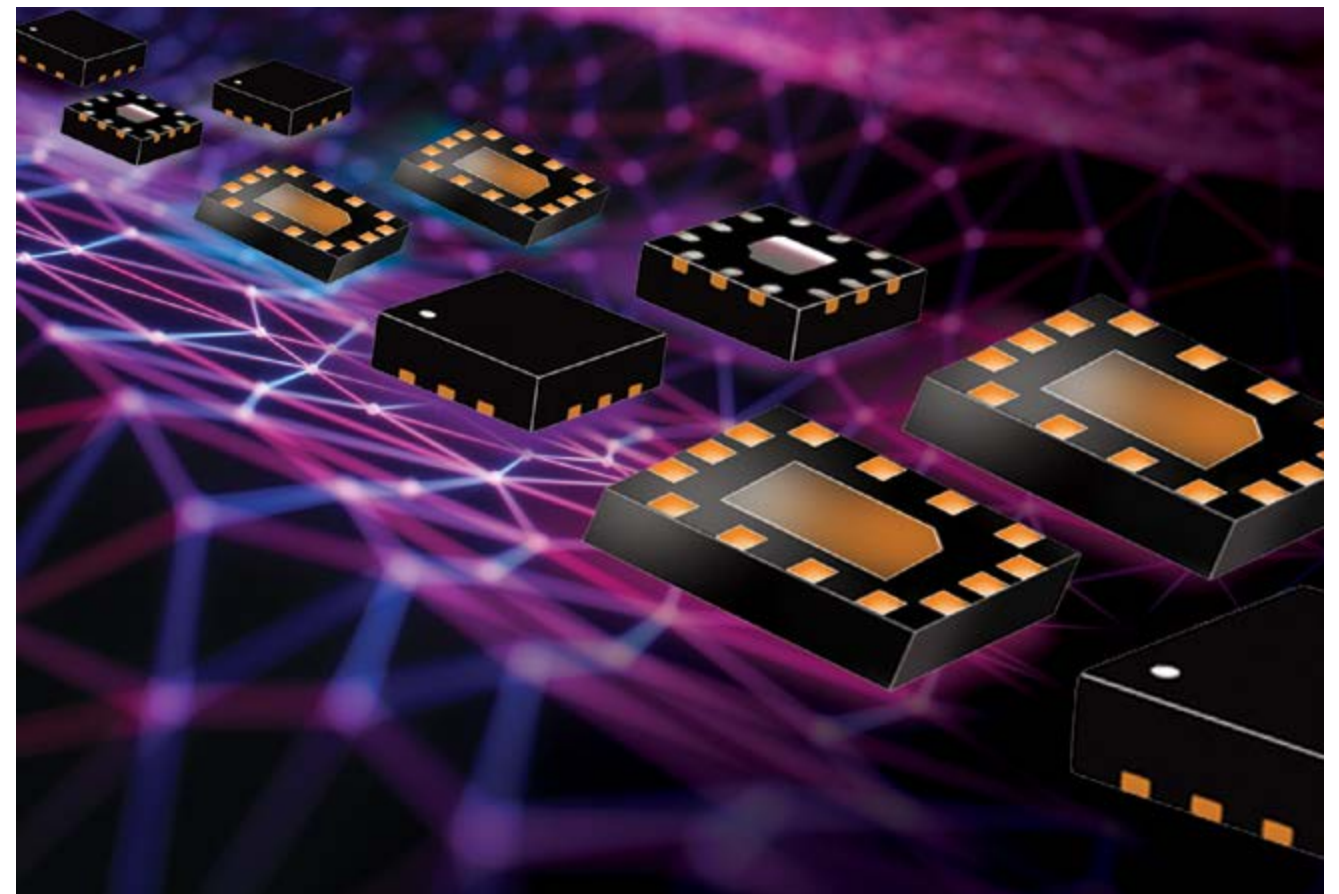

TEST ACCESSORIES

TEST ACCESSORIES

To support your testing needs from R&D to production test, Mini-Circuits provides a vast array of products for lab environments. We've highlighted a few of these products here, which are uniquely applicable to testing in CATV systems, but we encourage you to visit our website to explore our full offering of test solutions and accessories, which includes everything from adapters to integrated rack-mounted test systems.

MATCHING PADS FEATURES

- 50/75Ω
- Impedance Conversion
- Excellent VSWR, 1.15
- Power Handling up to 0.5W
- BNC and N-Type Connectors

75Ω USB SMART POWER SENSOR FEATURES

- CW Power Measurements
- Wide Dynamic Range, -30 to +20 dBm
- Fast Measurement Speed, 30ms
- Good VSWR, 1:03:1
- User-Friendly GUI Software Included
- Built-in Measurement Applications
- Complete DLLs for 32/64-bit Windows® Systems Included
- Complete Programming Instructions for Windows & Linux® environments

75Ω TEST CABLES FEATURES

- Performance Qualified to 20,000 flexures
- Return Loss up to 38 dB
- Low insertion loss
- Power Handling up to 338W
- Stainless Steel F-Type Connectors
- Available in Variety of Lengths



Matching Pads

Model Number	Freq. Range Low (MHz)	Nom. Attenuation (dB)	Attenuation Flatness (dB) Typ.	VSWR (:1), Typ.	Connector, 50 ohm	Connector, 75 ohm
BMP-5075+	DC-2000	5.7±0.10	0.3	1.22	BNC-Female	BNC-Male
BMP-5075R+	DC-2000	5.7±0.10	0.3	1.22	BNC-Male	BNC-Female
SFQFM-5075+	DC-3000	5.7	0.2	1.2	SMA-Female	F-Male
UNMP-5075+	DC-3000	5.7±0.15	0.3	1.3	N-Female	N-Male
UNMP-5075-33+	DC-3000	5.7±0.15	0.3	1.05	N-Female	N-Male
UNMP-R5075-33+	DC-3000	5.7±0.15	0.3	1.05	N-Male	N-Female
Z7550R-FMSF+	DC-2500	5.9	-	1.2	SMA-Female	F-Male



75Ω Power Sensor

Model Number	Control	Sensor Type	Impedance (Ω)	Frequency Range (MHz)	Input Power Range (dBm)	Measurement Speed (ms)
PWR-2.5GHS-75	USB	CW	75	0.1-2500	-30 to +20	BNC-Male



75Ω Test Cables

Model Number	Frequency Range (MHz)	Conn. 1	Conn. 2	Length (ft)	Insertion Loss (dB) @ 1 GHz	Insertion Loss (dB) @ 2 GHz	Insertion Loss (dB) @ 3 GHz	Return Loss (dB) @ 1 GHz	Return Loss (dB) @ 2 GHz	Return Loss (dB) @ 3 GHz
CBL-3NM-75+	DC-3000	N Male	N Male	3	0.41	0.6	0.7	30	26	24
CBL-6NM-75+	DC-3000	N Male	N Male	6	0.75	1.02	1.43	30	26	25
CBL-1MFM-75+	DC-3000	F Male	F Male	3.28	0.49	0.78	0.89	32	32	24
CBL-2FM-75+	DC-3000	F Male	F Male	2	0.32	0.45	0.61	38	34	25
CBL-3FM-75+	DC-3000	F Male	F Male	3	0.41	0.6	0.77	30.4	29.3	26.8
CBL-6FM-75+	DC-3000	F Male	F Male	6	0.77	1.12	1.43	32.4	29.5	28.3

TRANSFORMERS



NCS2-771-75+ NCS1-222-75+

Model Number	Freq. Range (MHz)	Single-Ended to Single-Ended	Single-Ended to Balanced	Balanced to Balanced	Center Tap	DC Isolation	Impedance Ratio	Technology
NCS2-771-75+	240-770	N	Y	N	N	Y	2	LTCC
NCS1-222-75+	950-2200	N	Y	N	N	Y	1	LTCC



TC Family TC1-33-75G2+

TC1-1T-75X+	5-120	N	Y	Y	Y	Y	1	CORE & WIRE
TC9-1-75+	0.3-475	Y	N	N	N	N	0.11	CORE & WIRE
TC9-1-75X+	0.3-475	Y	N	N	N	N	0.11	CORE & WIRE
TC1.33-1T-75X+	3-500	N	Y	Y	Y	Y	1.33	CORE & WIRE
TC4-6T-75X+	0.6-600	N	Y	Y	Y	Y	4	CORE & WIRE
TCM2-142-75X+	10-1400	N	Y	Y	N	N	2	CORE & WIRE
TC1.33-282X+	5-2800	N	Y	Y	N	N	1.33	CORE & WIRE
TC1-1-13M-75X+	4.5-3000	N	Y	Y	N	N	1	CORE & WIRE
TC1-33-75G2+	5-3000	N	Y	Y	N	N	1	CORE & WIRE
TC4-122-75X+	40-1250	N	Y	Y	Y	N	4	CORE & WIRE

TRANSFORMERS

Mini-Circuits offers an industry-leading selection of RF transformers for DOCSIS 3.1 compliant systems and equipment. Our line includes a variety of configurations including single-ended to single ended, single-ended to balanced, and balanced to balanced, designs with impedance ratios ranging from 1:1 to 4:1.

FEATURES

- Insertion Loss as low as 0.6 dB
- Impedance Ratios from 1:1 to 4:1
- Various Configurations with and without Center Taps
- Power Handling up to 1W
- LTCC and Core-and-Wire Designs



ADTL1-4-75+

Model Number	Freq. Range (MHz)	Single-Ended to Single-Ended	Single-Ended to Balanced	Balanced to Balanced	Center Tap	DC Isolation	Impedance Ratio	Technology
ADT3-1T-75+	1-500	N	Y	Y	Y	Y	3	CORE & WIRE
ADT1-1WT+	0.4-800	N	Y	Y	Y	Y	1	CORE & WIRE
ADTL1-4-75+	0.5-1000	N	Y	Y	N	N	1	CORE & WIRE
ADTL1-15-75+	10-1500	N	Y	Y	N	N	1	CORE & WIRE
ADTL1-18-75+	5-1800	N	Y	Y	N	N	1	CORE & WIRE



TRS2-32-75+



TRS2-1T-75+



TX-2-5-1+



TRS1-182-75+



TRS1-23-75+

TRS2-32-75+	1-300	N	Y	N	N	Y	0.5	CORE & WIRE
TRS2-1T-75+	5-1200	N	Y	N	N	N	2	CORE & WIRE
TX-2-5-1+	20-1250	N	Y	Y	Y	Y	2	CORE & WIRE
TRS1-182-75+	10-1800	N	Y	Y	N	N	1	CORE & WIRE
TRS1-23-75+	10-2200	N	Y	Y	N	N	1	CORE & WIRE

VOLTAGE CONTROLLED OSCILLATORS

For High Frequency Clock Circuits



VCO'S

Clock jitter contribution to Bit-Error-Rate (BER) degradation in high performance systems that utilize high-speed Analog-to-Digital conversion (ADC/DAC) is a common concern and directly related to the integrated phase noise performance of the ADC/DAC clock source.

A common approach to generating high-frequency clock signals is direct multiplication of high-fidelity crystal oscillators. This approach results in excellent close-in phase noise and is relatively inexpensive.

However, as multiplication factors increase, and inter-stage amplifiers are added to offset the multiplication loss, the resultant growth in far-out phase noise makes the total integrated phase noise a major contributor in BER degradation.

A simple alternative to direct multiplication is the use of a Phase Locked Loop oscillator at the fundamental clocking frequency. In this approach, the total integrated noise is minimized (because no multiplication is involved), and the challenge shifts to managing the phase noise close to the carrier.

This challenge is overcome by using high performance, fixed-frequency, super-low phase noise voltage controlled oscillators. In this class of oscillator, the ceramic-resonator-based VCO is the ideal candidate and used extensively throughout the industry where direct conversion receivers/transmitters are deployed.

Mini-Circuits offers the fixed-frequency, low phase noise VCOs shown here as standard catalog models, but custom frequencies are available upon request (apps@minicircuits.com).

Model Number	Freq. Range (MHz)	Frequency (MHz)	Phase Noise @ 100 MHz Offset (-dBc/Hz)	Phase Noise @ 1 MHz Offset (-dBc/Hz)	Tuning Sensitivity (MHz/V)	Output Power (dBm)	Vcc (V)	Vtune (V)
ROS-4000C-X+	4000	120	143	162	2	+3	5	0.5-12
ROS-4608C-X+	4608	116	136	155	6	+3	8	0.5-4.5

ROS-4000C-X+ Typical Phase Noise

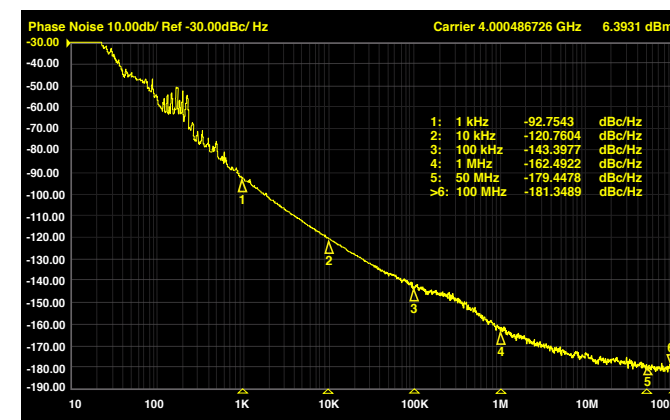

ROS-4608C-X+ Typical Phase Noise

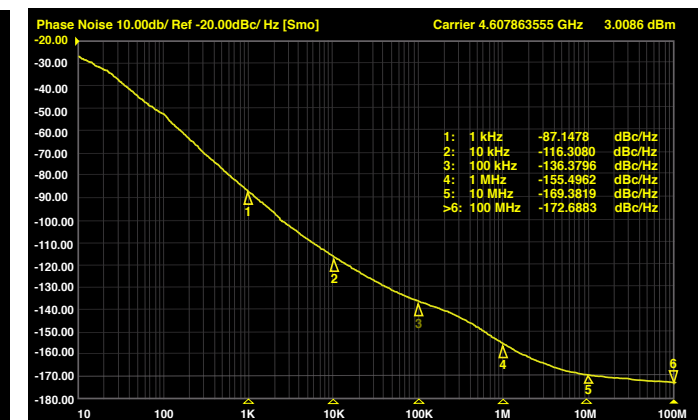

Application Block Diagram

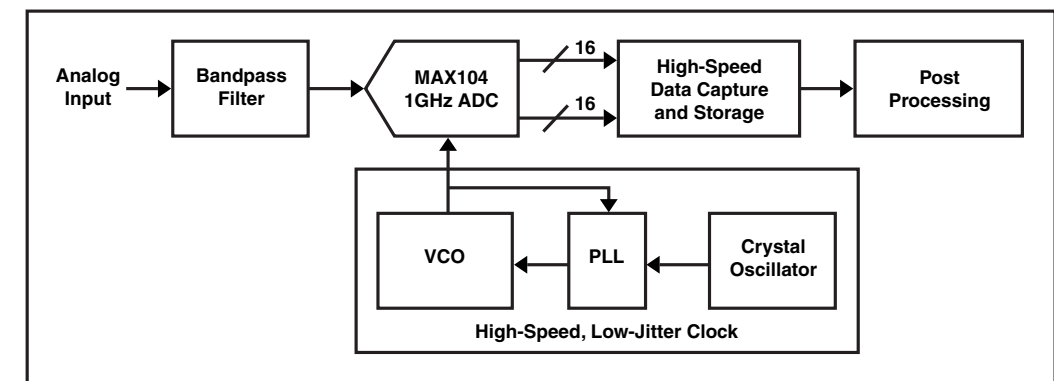

CATV/BROADBAND

2018 PRODUCT GUIDE



www.minicircuits.com

P.O. Box 350166, Brooklyn, NY 11235-0003

(718) 934-4500

sales@minicircuits.com



Direct Sales

- ▶ **Brooklyn**
sales@minicircuits.com
1 718-934-4500
- ▶ **Missouri**
sales@minicircuits.com
1 417-335-5935
- ▶ **Europe**
sales@uk.minicircuits.com
44 1252-832600
- ▶ **Taiwan**
robert@min-kai.com.tw
886 3 318 4450

Technical Support

- ▶ **NORTH AMERICA**
apps@minicircuits.com
(718) 934-4500
- ▶ **SINGAPORE, INDONESIA
MALAYSIA, THAILAND**
sales@minicircuits.com.my
(604) 646-2828
- ▶ **ISRAEL**
app@ravon.co.il
972 4 8749100
- ▶ **TAIWAN & PHILIPPINES**
robert@min-kai.com.tw
886 3 318 4450
- ▶ **EUROPE**
apps@uk.minicircuits.com
44 1252 832600
- ▶ **INDIA**
apps@minicircuits.com
91 44 2 2622575
- ▶ **CHINA**
sales@mitron.cn
86 591-8787 0001
Or
yuanzhong@minicircuits.com
86 020-8734 0992